



Indicator N1500LC

UNIVERSAL INDICATOR – INSTRUCTIONS MANUAL – V2.3x E

SAFETY ALERTS

The symbols below are used on the equipment and throughout this document to draw the user's attention to important operational and safety information.

CAUTION: Read this manual carefully prior to installation and operation of the unit.	CAUTION OR DANGER: Electric shock hazard

All safety related instructions that appear in the manual must be observed to ensure personal safety and to prevent damage to either the instrument or the system. If the device is used in a manner not specified in this manual, its safety features may be impaired.

INTRODUCTION

The N1500LC is an indicator designed for weighing system with load cells. It accepts a wide variety of electrical signals. It has a display with six-digit LED display for the measured value and device parameters.

The whole device configuration is done through the keyboard without any change in the circuit. Thus, the selection of input type and the type of alarms action, besides other special functions are all accessed and programmed through the front keypad.

It is important that you read this manual carefully before using the instrument. This is an electronic device that requires care in handling and operation, and if properly used, it will be very efficient in the work required.

The main features of the basic version of N1500LC are as follows:

- Input: 4-20 mA, 0-20 mA, 0-50 mV, 0-20 mV e -20 a 20 mV;
- Increasing or decreasing display;
- 10 Vdc (or 5 Vdc) power supply for load cells;
- Memory for maximum and minimum values;
- Hold, peak hold, tare, zero tare and automatic zero functions;
- Digital input;

Optionally can have:

- Process Variable (PV) retransmission in 0-20 mA ou 4-20 mA;
- RS485 MODBUS RTU serial communication;
- 3rd and 4th alarm relays.

The front panel is shown below, with a description of its elements.

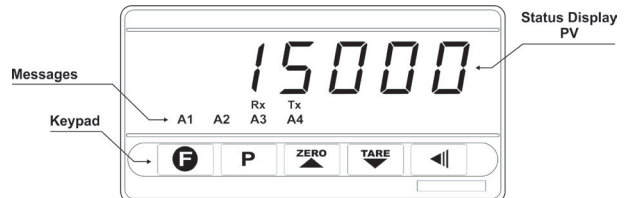

Figure 1 - Identification of the elements of the front panel

Display: Displays the value of the measured variable (PV) and the mnemonics of the device programming parameters.

A1, A2, A3 and A4: show active alarms.

Rx and Tx: indicate RS485 communication line is active.

P key - This key is used to access different displays with the programmable parameters of the device.

BACK key - This key is used to go back to the previous parameter displayed in the menu display.

INCREMENTS/ZERO key and DECREMENTS/ZERO key - They make possible the change the parameter values. They are also used to display maximum and minimum values stored in memory.

Key Special FUNCTION - This special function key is used for programmed functions as explained in the SPECIAL FUNCTION KEY section of this manual.

PROCESS VARIABLE INPUT - PV

The type of input to be used by the indicator must be set by the user via the keyboard, among types established in **Table 1**.

All input types available are factory calibrated and require no further adjustment by the user, except the definition of range of indication.

Type	Code	Measurement Range
Non-linear 4-20 mA	c.4-20	Programmable indication range. Three maximum range options: -32000 to +32000 0 to +60000 0 to +120000 (only even values)
Non-linear 0-20 mA	c.0-20	
Linear 4-20 mA	4-20 A	
Linear 0-20 mA	0-20 A	
Non-linear 0-50 mV	c.50	Nonlinear signals will be linearized according to the programmed linearization.
Non-linear -20 a 20 mV	c.-20	
Non-linear 0-20 mV	c.20	
Linear 0 – 50 mV	50	
Linear -20 a 20 mV	-20 . 20	
Linear 0-20 mV	20	

Table 1 - Input types accepted by the indicator

ALARMS

The indicator has 2 alarm outputs in the basic version and up to 4 alarms outputs optionally.

TYPE	PROMPT	ACTION
Disabled	oFF	Alarm disabled
Open Sensor (<i>input Error</i>)	IErr	Alarm will go ON if sensor breaks
High Alarm (<i>Low</i>)	Lo	
High Alarm (<i>High</i>)	Hi	
Differential Low (<i>differential Low</i>)	dIFLo	
Differential High (<i>differential High</i>)	dIFHi	
Differential out of range (<i>differential Fora</i>)	dIFF	
Differential within range (<i>differential Within</i>)	dIFd	

Table 2 - Alarm basic functions

Each alarm has a Warning Light in the front panel that shows when it was activated.

Alarm Functions

The alarms can be set to operate in six different modes: Open Sensor, Low alarm, High alarm, Differential low, Differential High or Differential (Band). These modes are shown in Table 2 and described below.

Open Sensor

The alarm is triggered whenever the sensor breaks or is badly connected or broken.

Low Alarm

The alarm relay is triggered whenever the measured value is **below** the alarm set point.

High Alarm

The alarm relay is triggered whenever the measured value is **above** the alarm set point.

Differential (or Band) out of range

For Differential alarm it is necessary to define two parameters: Differential Alarm Reference Value (**ALrEF**) and Alarm Differential Setpoint (Deviation).

The Differential out of range alarm occurs when the measured value is outside the range defined by:

$$(ALrEF - Deviation) \text{ and } (ALrEF + Deviation)$$

Differential (or Band) within range

Same as previous, but acting within the range defined above.

Differential Low

Triggered whenever the measured value is **below** the set point by:

$$(ALrEF - Deviation)$$

Differential High

Triggered whenever the measured value is **above** the set point by:

$$(ALrEF + Deviation)$$

Alarm Timer

The N1500LC allows programming of the Time Setting of Alarms, being able to set delays in alarm condition; send a single pulse at the time of trigger; or allow the generation of sequential pulses.

Table 3 shows these advanced functions. Times T1 and T2 can be programmed from 0 to 6500 seconds and are defined when setting up the device. For alarms with no time delays, set T1 and T2 with value 0 (zero).

The Warning LEDs associated with the alarm always light up when the alarm condition occurs, regardless of the current state of the output relay, which may be de-energized momentarily due to a time delay.

Advanced Function	T1	T2	ACTION
Normal Operation	0	0	
Delayed	0	1 s to 6500 s	
Pulse	1 s to 6500 s	0	
Oscillator	1 s to 6500 s	1 to 6500 s	

Table 3 - Timer Alarm Functions

Initial Block Alarm

The initial blocking option inhibits the alarm from being recognized if an alarm condition is present when the controller is first energized. The alarm will be triggered only after the occurrence of a non alarm condition followed by a new occurrence for the alarm. The initial blocking is disabled for the sensor break alarm function.

SPECIAL FUNCTIONS

SPECIAL FUNCTION KEY AND DIGITAL INPUT

The key (special function key) in the frontal panel of the controller as well as the Digital Input may be assigned different functions that will be chosen by the user during the setup. The possible functions are:

ZErO – Zero Function

Available only for the key. It resets the scale. This function is used to eliminate the influence of interference or small deviations in the zero of a scale. Reset is only accomplished if the value shown in the scale is within 2% of the end of scale. Zero is not lost if the scale is turned off.

Note: This function can be performed automatically using the parameters **EnR2** and **R2rAn**.

Lo – Displays Minimum

Set the key, to at the first tap, displays the **minimum (Low)** value the indicator measured since the last reset. On the second tap to show the maximum (High) measured by the indicator since the last reset. On the third ring, returns to normal display. Press the button for more than 5 seconds to reset, and the minimum and maximum values will be erased, starting a new cycle.

Hi – Displays Maximum

Displays the **maximum (High)** value the indicator measured since the last reset.

PHoLd – Maximum value

The indicator will automatically work in the **Peak Hold** mode whenever the key or the Digital Input are programmed as **"PHoLd"**.

This mode of operation mode the indicator always shows the maximum value measured, since the last time the key or the Digital Input were pressed.

Each activation of the key or digital input triggers a new Peak Hold cycle, reinitializing the reading of the display to the current value of the measure.

rSt - Clears Maximum and Minimum



If configured with "rSt", each activation of the  key or digital input clear the memory for a new cycle of maximum and minimum values.

Hold - Freeze Measured Value



The hold function freezes the measured value showed in the display. Each time the  key or the Digital Input is selected, there is a change from hold to normal mode.

Whenever the indicator is in the hold mode, the message "Hold" will be displayed so that the operator will be aware that the value displayed is the frozen value and not the current reading.

TARE - Tare Function

It is available only in the Digital Input configuration or through the  key. It changes indication to zero (0000.0), regardless of the value applied to the input. It is used to eliminate indications of defined values. In order to eliminate the tare, the user must press the  key.

TARE AND ZERO KEYS

The same Tare function available for the Digital Input can be quickly applied by using the  key, which does not need to be set up. The  key is used to eliminate the tare applied.

The indicator accepts successive tares provided that the input signal (gross weight) does not exceed the equipment end of scale.

PROCESS VARIABLE RETRANSMISSION

As an option, the indicator can be supplied with an isolated 0-20 mA or 4-20 mA analog output for Process Variable (PV) retransmission. Available at terminals 29 and 30 of the rear panel of the device. When this option is available, the retransmission is always enabled and does not require any user intervention.

The PV values that define the scale of the 0 mA / 4 mA to 20 mA retransmission can be programmed by the user in the high and low output limits (DULOL e DUHOL), at configuration level. These limits can be defined freely, and you can make a retransmission with increasing or decreasing behavior toward to the indicated value.

For a voltage output signal an external shunt (calibrated resistor) should be installed at the analog output terminals, according to your needs.

LOAD CELL POWER SUPPLY (AUXILIARY P. S.)

The indicator provides a voltage power supply of 10 Vdc to excite field transmitters with 50 mA current capacity. Available at the back panel terminals 16 and 17.

CUSTOMIZED LINEARIZATION

The indicator has five types of input for non-linear signals:

c.4-20, c.0-20, c.50, c.-20 e c.20

For using these signals is necessary to adopt the Custom Linearization option. This feature combines the input signal to 30 user-defined line segments; setting two points for each segment, a start and end and the respective display values. Thus the indication will have a non-linear behavior set by the input signal.

The following figure shows an input signal associated with four line segments (a, b, c, and d) causing that the resulting indication can be approximated to the ideal value (characteristic curve). The resulting indication is as best as the best straight segments are chosen.

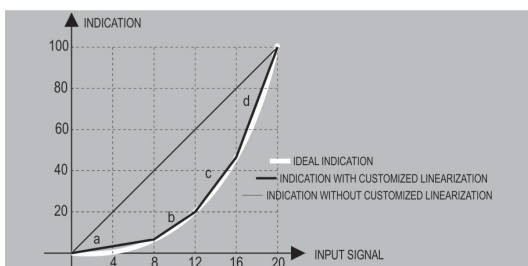



Figure 2 – Custom linearization for a nonlinear signal.

Note: The non-linear input signal shall have increasing pattern.

CONFIGURATION PROTECTION

As a safety measure, parameter changes can be prevented through a key combination performed at each level. With this protection, the parameters are still displayed but cannot be changed.

To protect any level, just go to the level and press the keys  and  simultaneously for 3 seconds.

To unlock the level, press the keys  and  for 3 seconds.

The display will flash briefly to confirm locking or unlocking level.

Inside the controller, the PROT key complements the protection function. In the OFF position, the user can do and undo the protection of cycles. In the ON position cannot make changes, if there are protections cycles these cannot be removed; if there is not, they cannot be promoted.

INSTALLATION

The indicator is designed to be panel mounted. Remove the two plastic fixing clamps from the instrument, insert the unit into the panel cut-out and slide firmly the fixing clamps from the rear against the panel.

Recommendations for installation

- The wires of the input signals must be installed separated from the output wires and power, if possible, in grounded conduits.
- The power supply for the instruments must be provided from an exclusive power source.
- In controlling and monitoring applications, possible consequences of any system failure must be considered in advance. The internal alarm relay does not warrant total protection.
- Use of RC FILTERS (47 R and 100 nF, serial) are highly recommended when driving solenoids, contactor coils or other inductive loads.

ELECTRICAL CONNECTIONS

The whole inner part can be removed without the need to make any disconnection. Figure 3 shows the connection arrangement at the rear panel of the indicator.

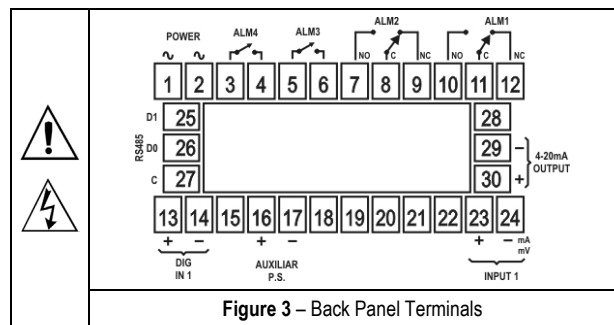

Figure 3 – Back Panel Terminals

Power Connection

First check if the voltage required by the indicator is compatible with the voltage of instrument power supply. Provide adequate protection devices.

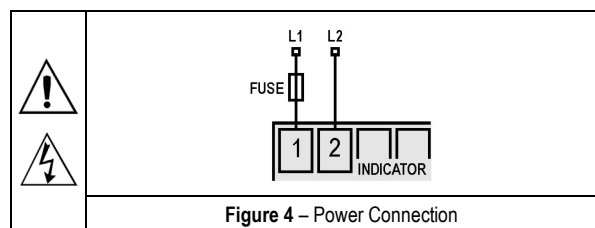
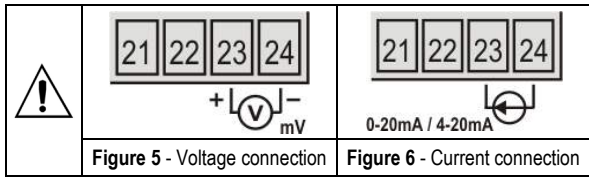

Figure 4 – Power Connection

Input signal connection

It is important that they are very well connected, the sensor wires must be well fixed in the terminals of the rear panel.



Load Cell Connection using the indicator power supply

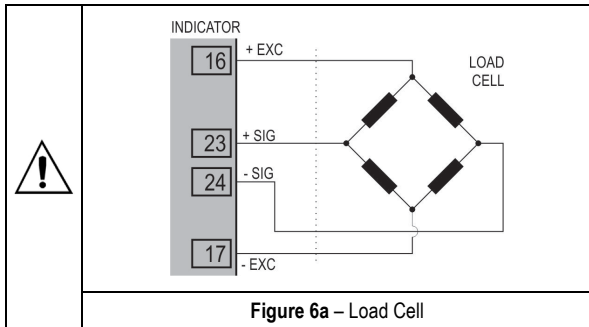

Digital Input (Dig In)

To use the Digital Input, a switch must be connected to respective terminals (dry contact), as shown in Figure 7.

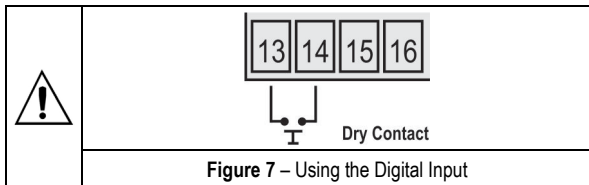

Analog output (4-20 mA OUTPUT)

The analog output may be 0-20mA or 4-20mA, selected in the configuration. The output is available at terminals 29 and 30, as requested in the purchase order.

OPERATION

For best results, this indicator requires correct basic setting of parameters or a definition for parameters displayed. It is necessary to define, for example: Type of input (0-20 mA, 4-20 mA, etc.), range display, alarm set point, alarm function, etc.

To make configuration easier, the parameters are divided in five levels (or groups):

Level	Access
1- Work	Free access
2- Alarms	Reserved access
3- Special Functions	
4- Input Setting	
5- Customized Linearization	
6- Calibration	
7- Automatic Calibration	

Table 4 - Parameters Levels

The work cycle has free access. All other levels require a certain combination of key strokes to be accessed. The combination is:

P and **◀** keys pressed simultaneously

Once within a cycle, just press **P** to move to the subsequent parameters of this cycle. At the end of each cycle the display will go back to the work cycle.

At the desired parameter, just press the buttons **▲** or **▼** to promote the desired changes. These changes are saved into protected memory and given as valid when we move to the next parameter.

After 25 seconds with no key pressed the indicator will return to the Measurement screen at work cycle.

PROGRAMMING THE INDICATOR

WORK LEVEL

This is the first level. At power up the indicator will display the Process Variable (PV). The alarm triggering points are also displayed at this level (alarm Setpoints). To advance in this level simply press **P**.

SCREEN	PARAMETER DESCRIPTION
BBBBB	Screen Measures - Shows the variable measured according to the limits defined in the "InLal" and "InHil" screens. Should any failure occur, the indicator will display an error message.
ALREF	Differential alarm reference value - This screen is shown only when there is an alarm programmed with differential function. This value is used as a reference for differential alarms triggering.
SPAL1 SPAL2 SPAL3 SPAL4	Alarms Set Points 1, 2, 3 and 4 - Defines the operation point of each alarm programmed with "Lo" or "Hi" functions. Note: For alarms programmed with differential functions, the alarm SP value cannot be changed, and the "dIF" message is displayed. The value of differential SP (deviation) is defined in the Alarms Cycle. NOTE: The SP adjustment parameters are presented only if the corresponding alarm function is configured.

ALARM LEVEL

FUAL1 FUAL2 FUAL3 FUAL4	Alarm Function - Defines the alarm functions: 1, 2, 3 or 4, as defined in item 4.1. OFF : Alarm off Err : Broken or Shorted Sensor Lo : Low value Hi : High value dIFL : Differential low dIFh : Differential high dIFF : Differential outside the range dIFd : Differential within range
HYAL1 HYAL2 HYAL3 HYAL4	Alarm Hysteresis Defines the difference between the value at which the alarm is turned on and the value at which it is turned off.
BLAL1 BLAL2 BLAL3 BLAL4	Initial Blocking Function It makes possible to prevent alarms activation at the process start, when all the system is powered. See item 4.3.
ALt1 ALt2 ALt1 ALt2 ALt1 ALt2 ALt1 ALt2	Alarm Timer Function Screens that define time T1 and T2, in seconds, shown in Table 3. They allow the user to delay the alarm triggering, to activate alarms momentarily or sequentially. To disable timer function, just set zero for T1 and T2.

FUNCTION LEVEL

FFunc	<p>F Key function – Makes possible to define the F key function. Available functions:</p> <ul style="list-style-type: none"> oFF - Key not used. HoLd - Hold PV rSt - Resets Maximum and Minimum values PHoLd - Peak Hold H I - Displays maximum Lo - Displays minimum ZEro - Automatic zero <p>These functions are described in item 5.</p>
d I.L. In	<p>Digital Input Function - Makes possible to define the digital input function. Functions available are the same as the ones available for the F key, except for the Zero function, replaced by the Tare function.</p> <p>oFF - HoLd - rSt - PHoLd - H I - Lo - tARrE</p> <p>These functions are described in item 5.</p>
F ILtEr	<p>Input Digital Filter - Used to reduce the noise in the measured value. Adjustable from 0 to 60. 0 means the filter is off and 60 means maximum filtering. The filter slows down the response of the measured value.</p>
oFSEt	<p>Displayed offset - Added value to the measured value to correct the offset. Expressed in the unit configured input type.</p>
En RZ	<p>Enables Auto zero – Enables the auto-zero function of the indication. The indication will turn to zero if the input value is within the programmed range in RZrRn for 3 seconds.</p> <p>Auto-zero occurs when the indication is relatively stable. It is used to eliminate the influence of interference or small deviations in the zero of a scale.</p>
RZrRn	<p>Maximum level for zero – Maximum level of the scale zero deviation, where auto-zero is activated. This value can be programmed up to 2% of the end of scale.</p>
bAud	<p>Communication Baud-Rate - Transmission baud rate used in serial communication (RS-485) in bps and kbps.</p> <p>1200, 2400, 4800, 9600, 19200, 38400, 57600, 115.2. (NONE parity) 1.2P, 2.4P, 4.8P, 9.6P, 19.2P, 38.4P, 57.6P e 115.2P (with EVEN parity).</p>
RdrES	<p>Communication Address - A number that identifies the instrument in a communication network.</p>

CONFIGURATION LEVEL

In.tYP	<p>Input Type - Selects the input signal or sensor type to be connected to the PV terminals. Refer to Table 1 for options.</p> <p>Changing the input type causes all other parameters related to PV and alarms to be changed as well, therefore, this parameter shall be the first to be set.</p>
dPPoS	<p>Decimal Point Position - Determines the position of the decimal point in the display.</p>
ScALe	<p>Parameter that defines the limits of indication of entries.</p> <ul style="list-style-type: none"> 0 – Configurable indication from – 31000 to + 31000. 1 – Configurable indication from 0 to + 60000. 2 – Configurable indication from 0 to +120000, showing only even values. <p>The PV values, SP Alarms and Offset also obey these limits.</p>



In.LoL	<p>Input Low Limit - Determines the minimum limit for input signals. The band created can be ascending or descending characteristic in relation to the input signal behavior.</p>
In.H IL	<p>Input High Limit - Determines the maximum limit for input signals. The band created can be ascending or descending characteristic in relation to the input signal behavior.</p>
ou.t.tY	<p>Analog Output Type - Allows selecting the type of signal available on the analog output: 0-20 mA or 4-20 mA.</p>
ou.LoL Output Low Limit	<p>Low Limit for analog retransmission – Determines the display value corresponding to an electric current of 4 mA (or 0 mA).</p>
ou.H IL Output High Limit	<p>High Limit for analog retransmission - Defines the PV value that results in a 20 mA analog output current.</p>
ou.t.Er Output error	<p>Error signaling for 4-20mA output - Configure the state of the analog output when an error occurs in the retransmission (beginning or end of the scale).</p>



CUSTOMIZED LINEARIZATION LEVEL

In.P.0 I In.P.30	<p>Defines the extreme points of the customized linearization. Values must be in the input signal unit.</p>
ou.t.0 I ou.t.30	<p>Defines the proportional indications in respect to each segment of the customized linearization. Values are in the intended indication unit.</p>

CALIBRATION LEVEL



All input and output types are factory calibrated, and we recommend not making any calibration procedure. This level should only be accessed by experienced personnel.

If this level is accidentally accessed do not touch the  or  keys, go through all the screens until you return to operating cycle (operation).

In.LoC	<p>Zero Input Calibration - It allows you to calibrate the offset of PV. You can increment or decrement the desired value tapping the keys  and .</p>
In.H IL	<p>Span Input Calibration - Sets the gain of PV.</p>
ou.LoC	<p>Zero Calibration for the Analog Output - Value for the analog output offset (0 or 4 mA).</p>
ou.H IL	<p>Analog Output Span Calibration – Value for gain calibration of the analog output (20mA).</p>
H.tYPE	<p>Hardware Type - Parameter to adjust the indicator to the type of available hardware. Should not be changed by the user, except when a new accessory is inserted or removed.</p> <ul style="list-style-type: none"> 2 Alarms code 3 2 Alarms and 4-20 mA..... code 19 2 Alarms and RS485 code 35 2 Alarms and 4-20 mA and RS485.... code 51 4 Alarms code 15 4 Alarms and 4-20 mA..... code 31 4 Alarms and RS485 code 47 4 Alarms and 4-20 mA and RS485.... code 63

AUTOMATIC CALIBRATION LEVEL

Specific calibration for weighing systems, where the user himself performs the calibration of their system, using two reference weights, minimum and maximum, and setting their indication values.

To access this cycle press and keep pressed  and  for 30 seconds.

ACALL	Minimum weight automatic calibration – This parameter defines the value to be displayed when the minimum reference weight is applied. See the section Performing Auto Calibration.
--------------	---

ACALH	Maximum weight automatic calibration – This parameter defines the value to be displayed when the maximum reference weight is applied. See the section Performing Auto Calibration.
--------------	---

Table 5 shows the sequence of levels and parameters presented in the indicator display. There are parameters that must be defined for each alarm available.

WORK LEVEL	ALARM LEVEL	FUNCTION LEVEL	CONFIGURATION LEVEL	CUSTOMIZED LINEARIZATION LEVEL	CALIBRATION LEVEL	AUTOMATIC CALIBRATION LEVEL
BBBBB	* FwAL 1	FFunC	InLYP	InPD 1 - InP.30	InLoC	ACALL
RLrEF	* HYAL 1	d IG. In	dPPoS	out.0 1 - out.30	InH IL	ACALH
* SPAL 1	* bLAL 1	F ILtr	ScALE		ouLoC	
	* AL. It 1	oFSEt	InLoL		ouH IL	
	* AL. It 2	En R2	InH IL		HtYPE	
		R2 rAn	out.tY			
		bAud	ouLoL			
		RdrES	ouH IL			
			out.Er			

Table 5 - Sequence of levels and parameters displayed by the indicator

* Parameters that require definition for each available alarm.

PROBLEMS WITH THE INDICATOR

Connection errors or improper configuration will result in malfunctioning of the indicator. A final review can avoid wasting time and losses.

The indicator some error messages will help the user identify possible problems.

MESSAGE	PROBLEM DESCRIPTION
UUUUU	Measured value is above the value allowed for the selected sensor or signal limit.
DDDDD	Measured value is below the value allowed for the selected sensor or signal limit.
-----	Open input. No signal.

Other error messages shown by the indicator must be reported to the manufacturer. Inform the serial number if this should occur. The serial number can be viewed at the display by pressing the key for about 3 seconds.

The software version of the instrument can be viewed at the time the unit is powered.

When not properly configured, the instrument may show false error messages, particularly those related to the type of input selected.

SPECIAL RECOMMENDATIONS

Should the indicator be repaired, some special handling care should be taken. The device must be withdrawn from the case and immediately placed in an anti-static wrap; protected from excessive heat and humidity.

INPUT CALIBRATION

An appropriate framework should be available for calibration of equipment capable of providing the electrical signals needed with the required accuracy.

When recalibration of some type of input is required, proceed as described below.

- Set the indicator for the input type to be calibrated, see Table 1;
- Program the desired upper and lower display limits (**InLoL** and **InH IL**) with limits on the type of configured input, see Table 1;
- Access the parameter "**InLoC**" and applied to input a signal corresponding to a known value and slightly above of the lower limit.
- Set the indicated value using the keys and to adjust the expected value for the applied signal.
- Access the parameter "**InH IL**" and applied to input a signal corresponding to a known value and slightly below of the upper limit.
- Set the indicated value using the keys and to adjust the expected value for the applied signal.
- Exit the calibration cycle and verify that the calibration became adequate. Repeat c to f until no new adjustment is necessary.

AUTOMATIC CALIBRATION

To perform automatic calibration, the system must already be installed and configured with the input type and range already defined.

- Access the Auto Calibration cycle and the parameter **ACALL** .
- Put on the load cell the minimum reference weight and wait to stabilize.
- Adjust the parameter **ACALL** to display the desired value.
- Press the **P** button to save this value and advance to the parameter **ACALH**.
- Put on the load cell the maximum reference weight and wait to stabilize.
- Adjust the parameter **ACALH** to display the desired value.
- Press **P** to save this value and terminate the procedure. At this time the indicator will show the weight on the load cell.

SERIAL COMMUNICATION

The indicator can be supplied with an asynchronous RS-485 digital communication interface for master-slave connection to a host computer (master). The indicator always works as a slave.

Communication is always initiated by the master, which sends a command to the slave address with which to communicate. The addressed slave takes over the line and sends the requested reply.

The indicator accepts broadcast commands (addressed to all instruments of the network). In this type of command, the indicator does not send any response

The N1500LC uses signals compatible with the RS-485 standard allows 2-wire connection with a master and up to 31 indicators (and can address up to 247) with bus topology. Maximum connection distance: 1000 meters. Indicator off time: Maximum 2 ms after the last byte.

Communication signals are electrically isolated from the rest of the device, with selectable baud rate between 1200, 2400, 4800, 9600, 19200, 38400, 57600 and 115600 bps.

- Number of data bits: 8 with no parity or even parity. Number of stop bits: 1
- Response start time: maximum 100 ms after receiving the command.
- Protocol: MODBUS (RTU)

Signals from the RS-485 interface are:

D1 = D: Bidirectional data line.

D0 = \bar{D} : Inverted bidirectional data line.

C = GND: Optional connection. Improves communication performance.

In case the host computer does not have an RS-485 interface integrated shall be used an external RS232 ↔ RS485 converter.

Two parameters must be configured to use the serial communication interface: Communication Baud Rate (**bAud** parameter) and Communication Address (**AdrES** parameter).

SPECIFICATIONS

DIMENSIONS: 48 x 96 x 92 mm (1/8 DIN). Approximate weight: 250 g

PANEL CUT-OUT: 45 x 93 mm (+0.5 -0.0 mm)

POWER: 100 to 240 Vac/dc ($\pm 10\%$), 50/60 Hz
 Optional 24 V: 12 to 24 Vcc / 24 Vca (-10% / $+20\%$)
 Max. Consumption: 7.5 VA

ENVIRONMENTAL CONDITIONS:

Operating temperature: 5 to 50 °C

Maximum RH: 80 % up to 30 °C

For temperatures above 30 °C, decrease 3 % per °C

For indoor use; Installation category II, pollution degree 2;
 altitude < 2000 m

INPUT Voltage and Current; configurable according **Table 1**

Internal resolution: 128000 levels

Display resolution: 62000 levels

Input sample rate: 15 samples per second

Accuracy: 0.2 % of span.

Input impedance: 0-50 mV >10 M Ω

..... 0-20 mA, 4-20 mA: 15 Ω (+2 Vdc @ 20 mA)

ANALOG OUTPUT: 0-20 mA or 4-20 mA, 550 Ω max.

. 4000 levels, Isolated, for control or retransmission of PV and SP

RELAY OUTPUT: ALM1 and ALM2: SPDT: 3 A / 240 Vac (3 A / 30 Vdc Res.)

. ALM3 and ALM4: SPST-NA: 1.5 A / 250 Vac (3 A / 30 Vdc Res.)

AUXILIARY VOLTAGE SUPPLY: 5 or 10 Vdc, $\pm 1\%$, 35 mA

EMC: EN 61326-1:1997 and EN 61326-1/A1:1998

SAFETY: EN61010-1:1993 and EN61010-1/A2:1995

CONNECTIONS SUITABLE FOR TERMINAL TYPE FORK 6.3 MM

FRONT PANEL: POLYCARBONATE UL94 V-2; CASE: ABS + PC
 UL94 V-0

STARTS OPERATION AFTER 3 SECONDS CONNECTED TO
 POWER

IDENTIFICATION

N1500LC -	4R -	RT -	485 -	24V
A	B	C	D	E

A: Model **N1500LC** – Version dedicated for load cells

B: Relays outputs **blank** (2 relays) or **4R** (4 relays)

C: Analog output **RT** – (retransmission of PV in mA) or **blank**

D: Digital Communication **485** – (RS485, ModBus protocol) or **blank**

E: Power Supply **blank** (100-240 Vac/dc) or **24V** (24 Vdc/ac)

WARRANTY

Warranty conditions are available on our website
www.novusautomation.com.br/warranty.