

XSEL™ Process Gauge - Copper Alloy

Type 212.34 - Dry Case

Type 213.34 - Liquid-filled Case

WIKA Datasheet 21X.34

Applications

- For applications with high dynamic pressure pulsations or vibration a liquid filled case and socket restrictor are available
- Suitable for corrosive environments and gaseous or liquid media that will not obstruct the pressure system
- Process industry: chemical/petrochemical, power stations, mining, on and offshore, environmental technology, mechanical engineering and plant construction

Special features

- Excellent load-cycle stability and shock resistance
- Solid front thermoplastic case
- Positive pressure ranges to 1,000 psi
- XSEL™ Process Gauge with 5 year warranty on gauge and 10 year warranty on pressure system (see terms and conditions)
- All lower mount connection gauges are factory prepared for liquid filling

(LBM: must install membrane prior to field filling)

Standard Features

Design

ASME B40.100

Sizes

4½" & 6" (115 & 160 mm) dial size

Accuracy class

± 0.5% of span (ASME B40.100 Grade 2A)

Ranges

Vacuum / Compound to 200 psi
Pressure from 15 psi to 1,000 psi
or other equivalent units of pressure or vacuum

Working pressure

Steady: full scale value
Fluctuating: 0.9 x full scale value
Short time: 1.5 x full scale value

Operating temperature

Ambient: -40°F to +150°F (-40°C to +65°C) - dry
-4°F to +150°F (-20°C to +65°C) - glycerine filled
-40°F to +150°F (-40°C to +65°C) - silicone filled
Medium: +150°F (+65°C) maximum

Temperature error

Additional error when temperature changes from reference temperature of 68°F (20°C) ±0.4% for every 18°F (10°C) rising or falling. Percentage of span.



Bourdon Tube Pressure Gauge Model 212.34

Weather protection

Weather resistant (NEMA 3 / IP54) - without membrane
Weather tight (NEMA 4X / IP65) - dry case or filled case with membrane installed

Pressure connection

Material: Copper alloy
Lower mount (LM)
1/4" or 1/2" NPT with M4 internal tap

Restrictor

Material: Copper alloy (0.6 mm)

Bourdon tube

Material: Copper alloy
C-type

Movement

Copper alloy. Internal stop pin at 1.3 x full scale
Overload and underload stops - standard
Dampened movement - optional

Dial

White aluminum with black lettering, stop pin at 6 o'clock

Pointer

Black aluminum, adjustable

Case

Black fiberglass-reinforced thermoplastic (POCAN)
Solid front, blowout back
Turret-style case with built in rear flange lugs

Window

Clear acrylic with Buna-N gasket

Case filling

Glycerine 99.7% - Type 213.34

Optional extras

- Silicone dampened movement
- Panel mounting adaptor kit (field assembled)
- Silicone case filling
- Halocarbon case filling
- Cleaned for oxygen service
- Instrument glass or safety glass window
- Drag pointer (maximum reading indicator)
- Alarm contacts switches (magnetic or inductive)
- Special process connections
- Custom dial layout
- External zero adjustment (4.5" size only)

Dimensions

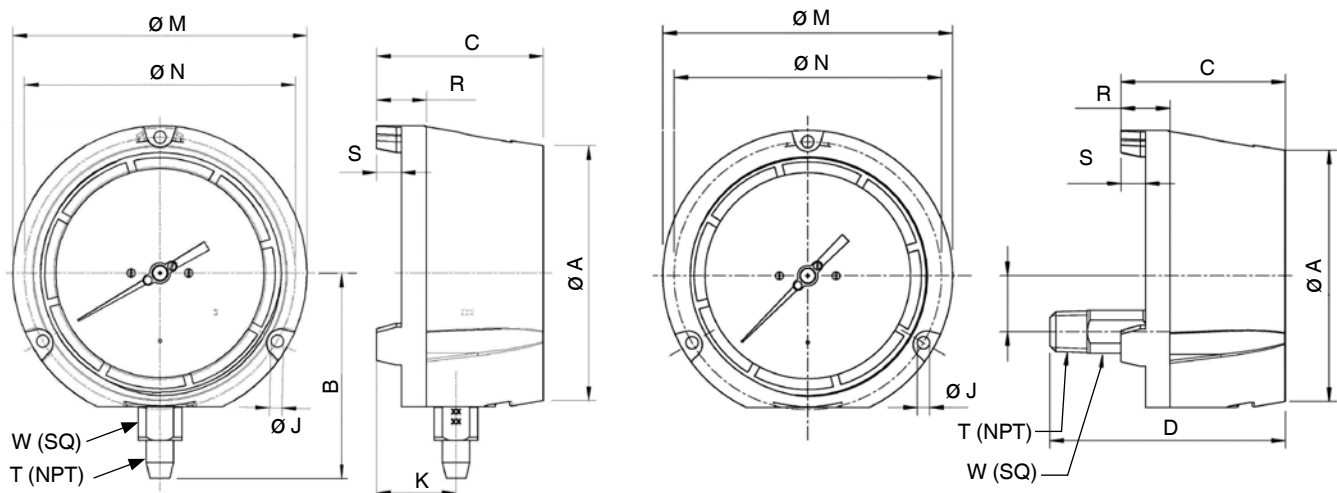

Size		A	B	C	D	J	K	L	M	N	R	S	T	W	Weight ¹	
4.5"	mm	128	103	84	120.3	6.3	40	28.5	148	136.5	25	12.5		22	2 lb.	dry
	in	5	4.06	3.31	4.74	0.248	1.57	1.12	5.83	5.37	0.99	0.49	1/2"	0.87	3 lb.	filled
6"	mm	164	122.5	88	123.4	7.1	40.2	28.5	190	177.8	25.4	12.7		22	3 lb.	dry
	in	6.46	4.82	3.46	4.86	0.28	1.58	1.12	7.5	7	1	0.5	1/2"	0.87	4 lb.	filled

¹ Weight without optional accessories

Ordering information

Pressure gauge model / Nominal size / Scale range / Size of connection / Optional extras required
Specifications and dimensions given in this leaflet represent the state of engineering at the time of printing.
Modifications may take place and materials specified may be replaced by others without prior notice.



WIKAI Instrument Corporation

1000 Wiegand Boulevard
Lawrenceville, GA 30043
Tel (770) 513-8200 Toll-free 1-888-WIKA-USA
Fax (770) 338-5118
E-Mail info@wika.com
www.wika.com