

Bourdon Tube Pressure Gauges

Paper Machine Gauge

Type 212.40PM - Dry Case

Type 213.40PM - Liquid-filled Case

WIKA Datasheet 21X.40PM

Applications

- With liquid filled case for applications with high dynamic pressure pulsations or vibration
- Paper machines and hydraulic presses
- Suitable for gaseous or liquid media that will not obstruct the pressure system

Special Features

- Excellent load-cycle stability and shock resistance
- Front flange for panel mounting
- Solid forged-brass case and connection



Bourdon Tube Pressure Gauge Model 212.40PM

Standard Features

Design

ASME B40.100 & EN 837-1

Nominal size

3½" (80 mm)

Accuracy class

± 2/1/2% of span (ASME B40.100 Grade A)

Ranges

Vacuum / Compound to 200 psi
Pressure from 15 psi to 15,000 psi
or other equivalent units of pressure or vacuum

Working pressure

Steady: ¾ full-scale value
Fluctuating: ⅔ full-scale value
Short time: full-scale value

Operating temperature

Ambient: -40°F to +140°F (-40°C to +60°C) - dry
-4°F to +140°F (-20°C to +60°C) - glycerine filled
Medium: max. +140°F (+60°C) ≤ 1,000 psi
max. +212°F (+100°C) ≥ 1,500 psi

Temperature error

Additional error when temperature changes from reference temperature of 68°F (20°C) ±0.4% for every 18°F (10°C) rising or falling. Percentage of span.

Weather protection

Weather resistant (NEMA 4 / IP 54)

Pressure connection

Material: copper alloy
¼" NPT lower back mount (LBM)

Bourdon tube

Material: copper alloy
≤ 1,000 psi: C-type, soldered
≥ 1,500 psi: helical type, brazed

Movement

Copper alloy

Dial

White aluminum with black lettering

Pointer

Black aluminum

Case

Forged brass with integral connection and blowout plug with polished stainless steel front flange. Suitable for liquid filling

Window

Acrylic with Buna-N gasket

Case fill

Glycerine 99.7% - Type 213.40PM

Optional extras

- Brass restrictor
- Flat glass or safety glass window
- Silicone or Fluorolube case filling
- Special connections limited to wrench flat area
- Custom dial layout
- Other pressure scales available
bar, kPa, MPa, kg/cm² and dual scales

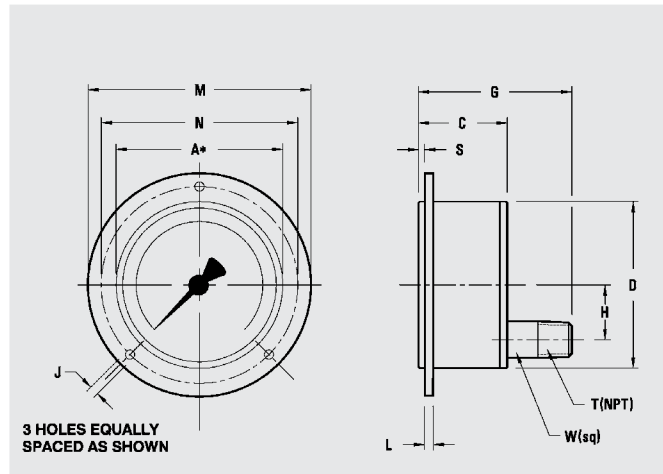

Size		A	C	D	G	H	J	L	M	N	S	T	W	Weight	
3.5"	mm	80	40	80	65	23	4.8	2	127	112	2.5		22	1.47 lb.	dry
	in	3.14	1.57	3.15	2.56	0.91	0.19	0.08	5.0	4.41	0.10	¼"	0.87	2.25 lb.	filled

Recommended panel cutout is dimension D + 1 mm

**WIKA Instrument, LP**

1000 Wiegand Boulevard
Lawrenceville, GA 30043-5868
Tel: 888-WIKA-USA • 770-513-8200
Fax: 770-338-5118
E-Mail: info@wika.com
www.wika.com