

Bourdon Tube Pressure Gauges Stainless Steel Series Type 232.50 - Dry Case Type 233.50 - Liquid-filled Case

WIKAI Datasheet 23X.50

Applications

- With liquid-filled case for applications with high dynamic pressure pulsations or vibration
- Suitable for corrosive environments and gaseous or liquid media that will not obstruct the pressure system
- Process industry: chemical/petrochemical, power stations, mining, on and offshore, environmental technology, mechanical engineering and plant construction

Special Features

- Excellent load-cycle stability and shock resistance
- All stainless steel construction
- Positive pressure ranges to 20,000 psi

Standard Features

Design

ASME B40.100 & EN 837-1

Sizes

2½", 4", 4½" & 6" (63, 100, 115 and 160 mm)

Accuracy class

2½": ± 2/1/2% of span (ASME B40.100 Grade A)
4", 4½" & 6": ± 1.0% of span (ASME B40.100 Grade 1A)

Ranges

Vacuum / Compound to 200 psi
Pressure from 0/15 to 0/15,000 psi - 2½", 4", 4½"
Pressure from 0/10 to 0/20,000 psi - 6"
or other equivalent units of pressure or vacuum

Working pressure

2½":
Steady: ¾ scale value
Fluctuating: ⅔ full-scale value
Short time: full-scale value

4", 4½" & 6":
Steady: full-scale value
Fluctuating: 0.9x full-scale value
Short time: 1.3x full-scale value

Operating temperature

Ambient: -40°F to +140°F (-40°C to +60°C) - dry
-4°F to +140°F (-20°C to +60°C) - glycerine-filled
-40°F to +140°F (-40°C to +60°C) - silicone-filled



Bourdon Tube Pressure Gauge Model 232.50

Medium: +392°F (+200°C) maximum - dry
+212°F (+100°C) maximum - liquid-filled

Temperature error

Additional error when temperature changes from reference temperature of 68°F (20°C) ±0.4% for every 18°F (10°C) rising or falling. Percentage of span.

Weather protection

Weather tight (NEMA 4X / IP65)

Pressure connection

Material: 316L stainless steel
Lower mount (LM) or lower back mount (LBM)
Center back mount (CBM) for 2½" size
¼" NPT or ½" NPT (other connections available)

Bourdon tube

Material: 316L stainless steel
≤ 1,000 psi: C-type
≥ 1,500 psi: helical type

Movement

Stainless steel

Dial

White aluminum with black lettering; 2½" with stop pin

Pointer

Black aluminum, adjustable

Case

- Stainless steel
 - 2½" - with pressure relief/fill plug on top of case
 - 4", 4½" and 6" - with blow out plug on back of case and fill plug on top of case
- For pressure ranges ≤ 160 psi, case has compensating valve/fill plug to vent case pressure

Bezel ring

Stainless steel, bayonet-type

Window

Polycarbonate (2½") and Safety Glass (4", 4½" & 6") with Buna-N gasket

Case fill

Glycerine 99.7% - Type 233.50

Optional extras

- Other pressure connections
- Monel wetted parts (Type 26X.50)
- Front flange, SS (CBM and LBM only)
- Rear flange, SS
- U-clamp mounting, SS (not available on 4½")
- Silicone or Halocarbon case filling
- Non-adjustable pointer
- Red drag pointer or mark pointer
- Safety glass window
- Custom dial layout
- Other pressure scales available: bar, kPa, MPa, kg/cm² and dual scales
- Integral alarm contacts or transmitters

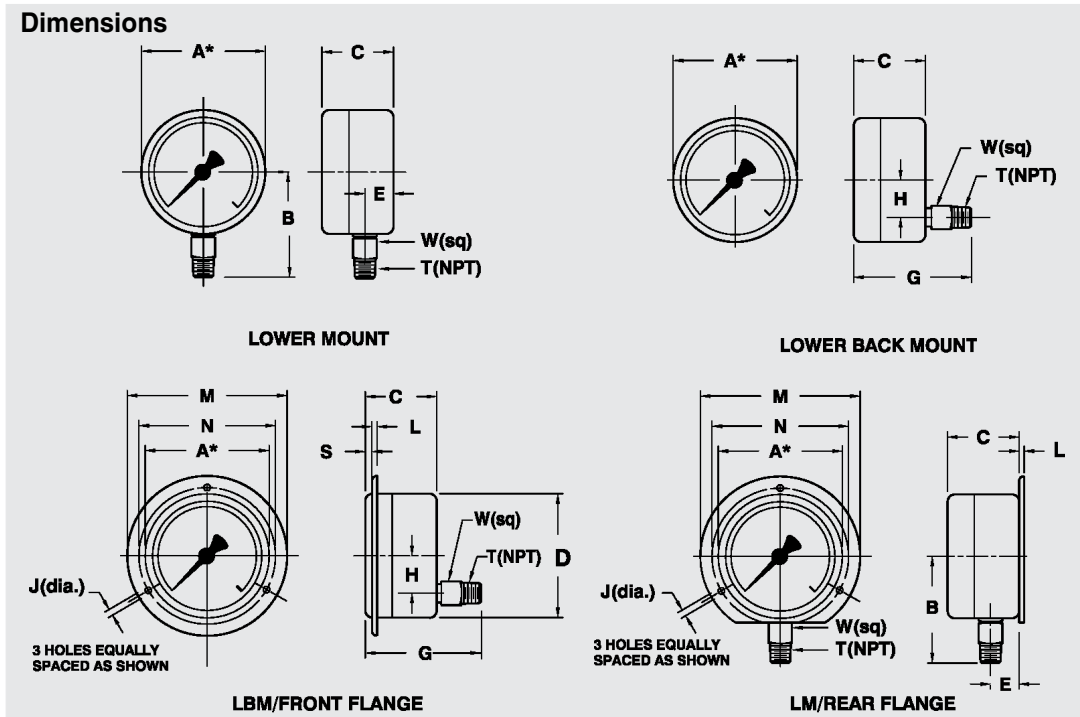

Size		A	B	C	D ¹	E	G	H	J	L	M	N	S	T	W	Weight ³
2½"	mm	63	54	33	62	9.5	57	Note1	3.6	3	85	75	5		14	0.35 lb. dry
	in	2.48	2.13	1.30	2.44	0.37	2.24		0.14	0.12	3.35	2.95	0.20	1/4"	0.55	0.44 lb. filled
4"	mm	101	86	49.5	99	15.5	83	30	4.8	3	132	116	5		22	1.32 lb. dry
	in	3.98	3.43	1.95	3.90	0.61	3.27	1.18	0.19	0.12	5.20	4.57	0.20	1/2"	0.87	1.98 lb. filled
4½"	mm	121	97	49.5	119	15.5	83	30	5	3	148	137	5		22	1.76 lb. dry
	in	4.76	3.82	1.95	4.68	0.61	3.27	1.18	0.2	0.12	5.83	5.39	0.20	1/2"	0.87	3.08 lb. filled
6"	mm	161	118	49.5 ²	163.71	15.5	83	50	5.8	3	196	178	5		22	2.42 lb. dry
	in	6.34	4.65	1.95 ²	6.45	0.61	3.27	1.97	0.23	0.12	7.72	7.01	0.20	1/2"	0.87	4.40 lb. filled

¹ Center back mount (CBM)

² Plus 0.63" (16 mm) for pressure ranges ≥ 1,500 psi

³ Weight without optional accessories

⁴ D (+) 1mm for panel cutout

Ordering information

Pressure gauge model / Nominal size / Scale range / Size of connection / Optional extras required
 Specifications and dimensions given in this leaflet represent the state of engineering at the time of printing.
 Modifications may take place and materials specified may be replaced by others without prior notice.



WIKAL Instrument Corporation

1000 Wiegand Boulevard
 Lawrenceville, GA 30045
 Tel (770) 513-8200 Toll-free 1-888-WIKA-USA
 Fax (770) 338-5118
 E-Mail info@wika.com
 www.wika.com