

Bourdon Tube Pressure Gauges

Stainless Steel Refrigeration Ammonia Gauge

Type 232.53AM - Dry Case

Type 233.53AM - Liquid-filled Case

WIKA Datasheet 23X.53AM

Applications

- Measuring refrigerant ammonia pressure and temperature
- Suitable for corrosive environments and gaseous or liquid media that will not obstruct the pressure system
- Process industry: chemical/petrochemical, power stations, mining, on and offshore, environmental technology, mechanical engineering and plant construction

Special features

- Excellent load-cycle stability and shock resistance
- All stainless steel construction
- Ammonia refrigerant scales on dial



Description

Design

ASME B40.100 & EN 837-1

Sizes

2½" & 4" (63 and 100 mm)

Accuracy class

2½": ± 2/12% of span (ASME B40.100 Grade A)

4": ± 1.0% of span (ASME B40.100 Grade 1A)

Ranges

30" Hg / 0 / 150 psi (84°F)

30" Hg / 0 / 300 psi (126°F)

Working pressure

2½": Steady: 3/4 scale value
Fluctuating: 2/3 full scale value
Short time: full scale value

4": Steady: full scale value
Fluctuating: 0.9 x full scale value
Short time: 1.3 x full scale value

Operating temperature

Ambient: -40°F to +140°F (-40°C to +60°C) - dry
-4°F to +140°F (-20°C to +60°C) - glycerine filled
-40°F to +140°F (-40°C to +60°C) - silicone filled
Medium: +212°F (+100°C)

Temperature error

Additional error when temperature changes from reference temperature of 68°F (20°C) ±0.4% for every 18°F (10°C) rising or falling. Percentage of span.

Weather protection

Weather tight (NEMA 4X / IP65)

Pressure connection

Material: 316L stainless steel
1/4" NPT, lower mount (LM)

Bourdon tube

Material: 316L stainless steel
C-type

Movement

Stainless steel

Dial

White aluminum with black lettering, 2½" with stop pin

Pointer

Black aluminum

Case

304 stainless steel with vent plug and SS crimp ring.
Case welded to socket

Window

Polycarbonate

Case fill

Glycerine 99.7% - Type 233.53AM

Optional extras

- SS restrictor
- SS rear flange
- Clean for oxygen service
- Red drag pointer for mark pointer
- Other pressure connections
- Silicone or Halocarbon case filling

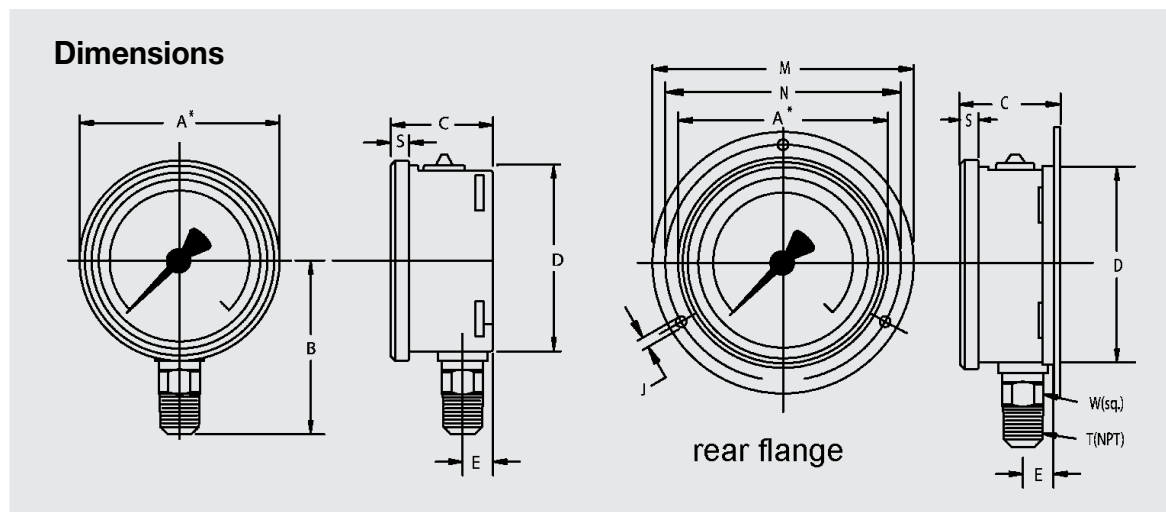

Size		A	B	C	D	E	J	L	M	N	S	T	W	Weight ¹
2.5"	mm	69	54	32	62	13	3.6	7.5	85	75	6.5		14	0.36 lb. dry
	in	2.69	2.13	1.26	2.45	0.51	0.14	0.30	3.35	2.95	0.26	1/4"	0.55	0.44 lb. filled
4"	mm	107	87	48	100	15.5	4.8	9	132	116	8		22	1.10 lb. dry
	in	4.21	3.43	1.89	3.91	0.61	0.19	0.35	5.20	4.57	0.31	1/2"	0.87	1.76 lb. filled

¹ Weight is without optional accessories

Ordering information

Pressure gauge model / Nominal size / Scale range / Size of connection / Optional extras required
Specifications and dimensions given in this leaflet represent the state of engineering at the time of printing.
Modifications may take place and materials specified may be replaced by others without prior notice.

**WIKA Instrument Corporation**

1000 Wiegand Boulevard
Lawrenceville, GA 30043
Tel (770) 513-8200 Toll-free 1-888-WIKA-USA
Fax (770) 338-5118
E-Mail info@wika.com
www.wika.com