

XSEL™ Process Gauge for NACE Sour Gas Service - Monel® Alloy Type 262.34 NACE- Dry Case Type 263.34 NACE- Liquid-filled Case

WIKA Datasheet 26X.34 NACE

Applications

- The WIKA 26X.34 NACE factory approved process gauge contains Monel® wetted parts materials that meet the recommendations and guidelines set forth by the NACE International standards MR0175 and MR0103
- Suitable in oil and gas production industries as well as refinery environments containing H₂S (Hydrogen Sulfide); commonly referred as “sour gas service”.
- Suitable for corrosive environments and gaseous or liquid media that will not obstruct the pressure system

- Excellent load-cycle stability and shock resistance
- Solid front thermoplastic case
- Positive pressure ranges to 15,000 psi
- All lower mount connection gauges are factory prepared for liquid filling
- Inspection Certificate to EN 10 204 - 2.2 (available upon request)
- XSEL™ Process Gauge with 5 year warranty on gauge and 10 year warranty on pressure system (see terms and conditions)

(LBM: must install membrane prior to field filling)

Standard Features

Design

ASME B40.100

Sizes

4½” & 6” (115 & 160 mm) dial size

Accuracy class

± 0.5% of span (ASME B40.100 Grade 2A)

Ranges

Vacuum / Compound to 200 psi
Pressure from 15 psi to 15,000 psi
or other equivalent units of pressure or vacuum

Working pressure

Steady: full scale value
Fluctuating: 0.9 x full scale value
Short time: 1.5 x full scale value

Operating temperature

Ambient: -40°F to +150°F (-40°C to +65°C) - dry
-4°F to +150°F (-20°C to +65°C) - glycerine filled
-40°F to +150°F (-40°C to +65°C) - silicone filled
Medium: max. +212°F (+100°C) (See Note 1 on reverse)

Temperature error

Additional error when temperature changes from reference temperature of 68°F (20°C) ±0.4% for every 18°F (10°C) rising or falling. Percentage of span.



Bourdon Tube Pressure Gauge Model 232.34 NACE

Weather protection

Weather resistant (NEMA 3 / IP54) - without membrane
Weather tight (NEMA 4X / IP65) - dry case or filled case with membrane installed

Pressure connection

Material: Monel® M400 (maximum hardness 35 HRC)
Lower mount (LM) or lower back mount (LBM)
1/4” or 1/2” NPT with M4 internal tap

Restrictor

Material: Monel® (0.6 mm)

Bourdon tube

Material: Monel® M400 (maximum hardness 35 HRC)
≤ 1,000 PSI: C-type
≥ 1,500 PSI: helical type

Movement

Stainless steel. Internal stop pin at 1.3 x full scale
Overload and underload stops - standard
Dampened movement - optional

Dial

White aluminum with black lettering, stop pin at 6 o'clock with “NACE Sour Gas Service” on dial

Pointer

Black aluminum, micro-adjustable

Case

Black fiberglass-reinforced thermoplastic (POCAN)
Solid front, blowout back
Turret-style case with built in rear flange lugs

Window

Clear acrylic with Buna-N gasket

Case filling

Glycerine 99.7% - Type 263.34

Note 1: The maximum continuous media temperature for this gauge is 212°F. However, higher temperatures can be maintained safely for short term exposure per table to the right. The user should consider temperature error and gauge component degradation when exposing gauge to any media or ambient temperature above 212°F. For continuous use in either ambient or media temperatures above 212°F, a diaphragm seal or other heat dissipating means is recommended. Consult factory for technical inquiries and application assistance.

Optional extras

- Silicone dampened movement
- Panel mounting adaptor kit (field assembled)
- Silicone case filling
- Halocarbon case filling
- Cleaned for oxygen service
- Instrument glass or safety glass window
- Drag pointer (maximum reading indicator)
- Alarm contacts switches (magnetic or inductive)
- Special process connections
- Custom dial layout
- External zero adjustment (4.5" size only)

Short term, intermittent maximum media temperature limits
(Optional glass window required for all these temperatures)

- 500°F (260 °C) - Dry Gauge
- 250°F (130°C) - Liquid filled gauge
- 300°F (150°C) - Dampened movement gauge

Dimensions

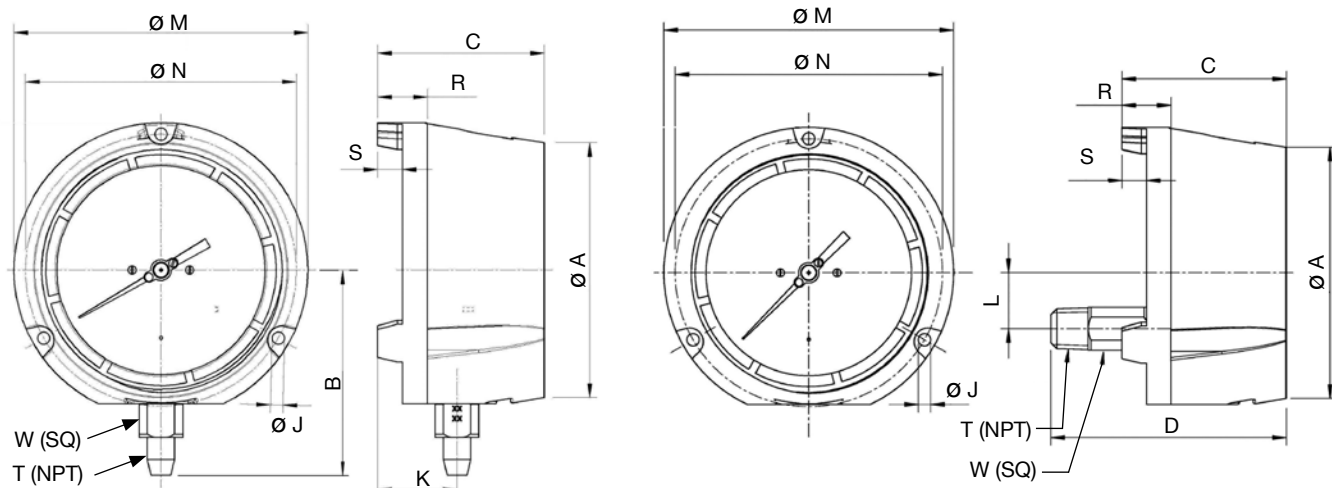

Size		A	B	C	D	J	K	L	M	N	R	S	T	W	Weight ¹
4.5"	mm	128	103	84	120.3	6.3	40	28.5	148	136.5	25	12.5	22	2 lb.	dry
	in	5	4.06	3.31	4.74	0.248	1.57	1.12	5.83	5.37	0.99	0.49	1/2"	0.87	3 lb. filled
6"	mm	164	122.5	88	123.4	7.1	40.2	28.5	190	177.8	25.4	12.7	22	3 lb.	dry
	in	6.46	4.82	3.46	4.86	0.28	1.58	1.12	7.5	7	1	0.5	1/2"	0.87	4 lb. filled

¹ Weight without optional accessories

Ordering information

Pressure gauge model / Nominal size / Scale range / Size of connection / Optional extras required
Specifications and dimensions given in this leaflet represent the state of engineering at the time of printing.
Modifications may take place and materials specified may be replaced by others without prior notice.



WIKA Instrument Corporation

1000 Wiegand Boulevard
Lawrenceville, GA 30043
Tel (770) 513-8200 Toll-free 1-888-WIKA-USA
Fax (770) 338-5118
E-Mail info@wika.com
www.wika.com