

# Diaphragm Pressure Gauges Process Industry Series Sealgaug<sup>®</sup> Type 432.50 - Dry Case / Type 433.50 - Liquid-filled Case

WIKA Datasheet 43X.50

## Applications

- With liquid-filled case optional for applications with high dynamic pressure pulsations or vibration
- Suitable in corrosive environments for gaseous, liquid or highly viscous media
- Process industry: chemical/petrochemical, power stations, mining, on and offshore, environmental technology, mechanical engineering and plant construction
- Ideally for applications in the water/wastewater industry

## Special Features

- Wide selection of special materials
- All stainless steel construction
- High overpressure safety

## Standard Features

### Design

EN 837-3

### Sizes

4" & 6" (100 & 160 mm)

### Accuracy class

± 2.5% of span

### Ranges

Vacuum / Compound to 300 psi  
Pressure from 10" H<sub>2</sub>O to 250" H<sub>2</sub>O (6" flange diameter)  
Pressure from 10 psi to 360 psi (4" flange diameter)  
or other equivalent units of pressure or vacuum

### Working pressure

Steady: full-scale value  
Fluctuating: 0.9 x full-scale value

### Overpressure safety

5 x full-scale value, not exceeding 600 psi

### Operating temperature

Ambient: -4°F to +140°F  
Medium: +212°F maximum  
Storage: -40...+158°F (ranges ≤ 25" WC: -4...+158°F)



Diaphragm Pressure Gauge Model 432.50

### Temperature error

Additional error when temperature changes from reference temperature of 68°F (20°C) ±0.8% of span for every 18°F (10°C) rising or falling.

### Weather protection

Weather resistant (NEMA 3 / IP54) - dry case  
Weather tight (NEMA 4X / IP65) - liquid-filled case

### Case and upper diaphragm housing

Material: stainless steel  
Case with pressure relief disc and stainless steel bayonet ring

### Pressure connection and lower diaphragm housing

Material: 316L SS  
Lower mount (LM)  
½" NPT female

### Diaphragm element

≤ 100" H<sub>2</sub>O: 316 SS with PTFE lining  
> 100" H<sub>2</sub>O: Inconel<sup>®</sup> (NiCr-alloy) with PTFE lining  
All ranges with FPM (Viton) sealing gasket

### Movement

Material: stainless steel

## Dial

White aluminum with black lettering

## Pointer

Black aluminum, adjustable - Type 432.50

Black aluminum, non-adjustable - Type 433.50

## Window

Laminated safety glass with Buna-N gasket

## Case fill

Standard dry

Glycerine 86.5% - Type 433.50

## Optional extras

- 10X overpressure safety, max. 600 psi
- Underpressure safe to -30"Hg
- Silicone or fluorolube case filling
- Special connections limited to wrench flat area
- Open flange connections (300# ASME maximum)
- Instrument glass or acrylic window
- Cleaned for oxygen service
- Extended media temperature to +392°F
- Exotic metal or PTFE lining for open flanges
- Alarm contacts switches (magnetic or inductive)
- Special process connections
- Custom dial layout

## Dimensions

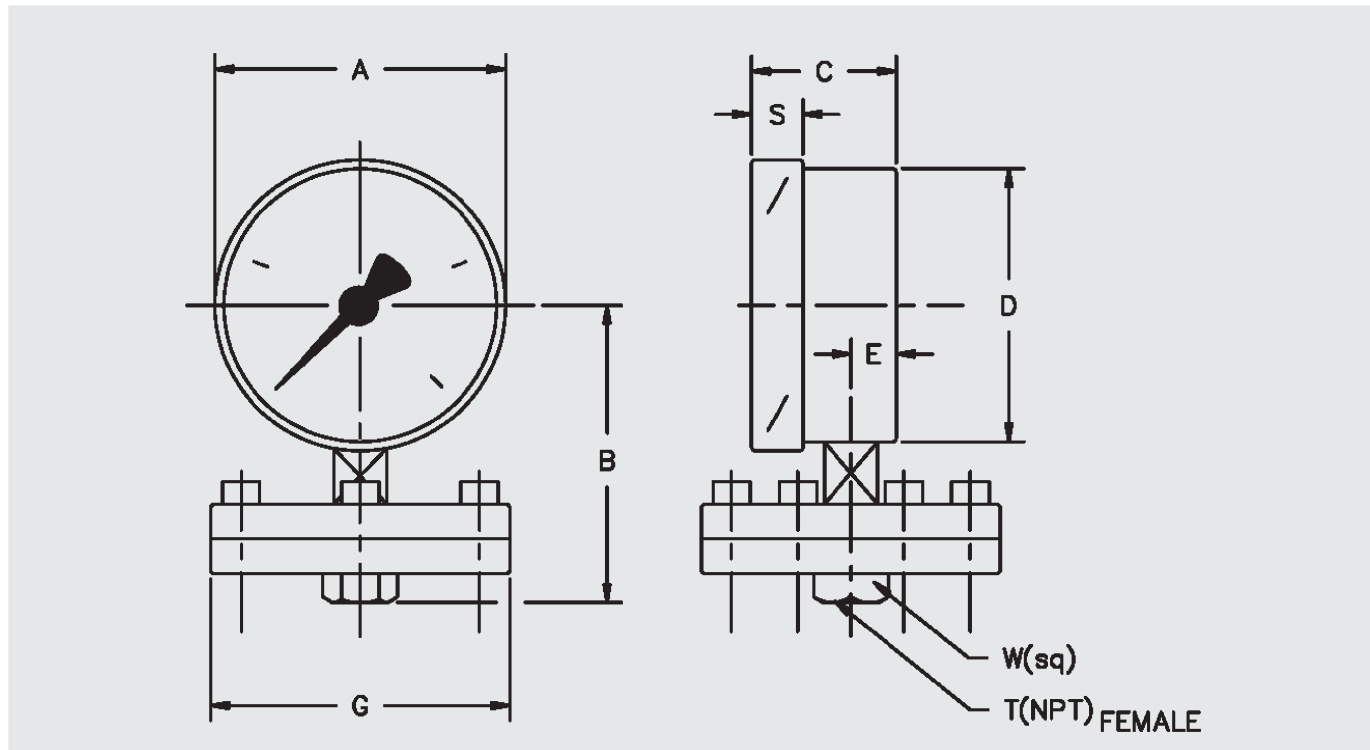

Size		A	B	C	D	E	G <sup>1</sup>	S	T	W	Weight
4"	mm	100	104	49.5	99	15.5	100	17.5		27	
	in	4.0	4.09	1.95	3.90	0.61	3.94	0.69	1/2"	1.06	3.1 lb.
6"	mm	160	134	49.5	159	15.5	100	17.5		27	
	in	6.0	5.28	1.95	6.26	0.61	3.94	0.69	1/2"	1.06	4.0 lb.

<sup>1</sup> For ranges 100"H<sub>2</sub>O and lower, G dimension changes to 160 mm (6") and weight increases by 1.0 lb.

## Ordering information

Pressure gauge model / Nominal size / Scale range / Size of connection / Optional extras required.  
Specifications and dimensions given in this leaflet represent the state of engineering at the time of printing.  
Modifications may take place and materials specified may be replaced by others without prior notice.



## WIKA Instrument, LP

1000 Wiegand Boulevard  
Lawrenceville, GA 30043-5868  
Tel: 888-WIKA-USA • 770-513-8200  
Fax: 770-338-5118  
E-Mail: info@wika.com  
www.wika.com