

# AUTOMATION

PRODUCTS  
GROUP, INC.

**Operator's Manual**

## **KA Series**

### **Liquid Level Controls**

9004020  
Rev. B, 08/14



**Automation Products Group, Inc.**

***APG...Providing tailored solutions for measurement applications***

Tel: 1/888/525-7300 • Fax: 1/435/753-7490 • [www.apgsensors.com](http://www.apgsensors.com) • E-mail: [sales@apgsensors.com](mailto:sales@apgsensors.com)

---

## Table of Contents

<i>Warranty</i> .....	3
<i>Introduction</i> .....	4
<i>Specifications</i> .....	5
<i>Dimensions</i> .....	5
<i>Options</i> .....	6
<i>Chemical Compatibility—Corrosion Resistance</i> .....	6
<i>Cable Weights</i> .....	7
<i>Cable Specifications</i> .....	7
<i>Switch Wiring and Type Detail Table</i> .....	8
<i>Selecting the Right Switch</i> .....	9
<i>Understanding the Switch Action/Terminology</i> .....	10
<i>Single vs. Dual Point Control</i> .....	10
<i>Single Point with Timed Relay Control</i> .....	11
<i>Emptying/Filling Pump Control Circuits</i> .....	11
<i>Duplex Pump Control Circuit</i> .....	12
<i>Operating Level Adjustment</i> .....	13
<i>Termination and Height Fixing</i> .....	14
<i>Position in Tank/Swing Distance Allowance</i> .....	15
<i>Control Contact Ratings</i> .....	16
<i>Verifying Operation</i> .....	16
<i>Tips</i> .....	17
<i>Certificate of Compliance</i> .....	18

## • **Warranty and Warranty Restrictions**

APG warrants its products to be free from defects of material and workmanship and will, without charge, replace or repair any equipment found defective upon inspection at its factory, provided the equipment has been returned, transportation prepaid, within 24 months from date of shipment from factory.

THE FOREGOING WARRANTY IS IN LIEU OF AND EXCLUDES ALL OTHER WARRANTIES NOT EXPRESSLY SET FORTH HEREIN, WHETHER EXPRESSED OR IMPLIED BY OPERATION OF LAW OR OTHERWISE INCLUDING BUT NOT LIMITED TO ANY IMPLIED WARRANTIES OF MERCHANTABILITY OR FITNESS FOR A PARTICULAR PURPOSE.

No representation or warranty, express or implied, made by any sales representative, distributor, or other agent or representative of APG which is not specifically set forth herein shall be binding upon APG. APG shall not be liable for any incidental or consequential damages, losses or expenses directly or indirectly arising from the sale, handling, improper application or use of the goods or from any other cause relating thereto and APG's liability hereunder, in any case, is expressly limited to the repair or replacement (at APG's option) of goods.

Warranty is specifically at the factory. Any on site service will be provided at the sole expense of the Purchaser at standard field service rates.

All associated equipment must be protected by properly rated electronic/electrical protection devices. APG shall not be liable for any damage due to improper engineering or installation by the purchaser or third parties. Proper installation, operation and maintenance of the product becomes the responsibility of the user upon receipt of the product.

Returns and allowances must be authorized by APG in advance. APG will assign a Return Material Authorization (RMA) number which must appear on all related papers and the outside of the shipping carton. All returns are subject to the final review by APG. Returns are subject to restocking charges as determined by APG's "Credit Return Policy".

• **Introduction**

KA series controls consist of a free-floating switch enclosure to which a protected multiconductor cable is attached. Inside the float there are a number of microswitches set at different angles. A control weight is fixed at a point along the cable to keep the cable immersed in the liquid. The suspended float switch follows the movement of the liquid level. As the liquid level rises and falls, the weight on the cable causes the inclination of the float to change. This tilting action results in microswitches opening and closing, sequentially, at different elevations. The switch-operating levels are easily adjusted by moving the weight along the cable and/or altering the height of the cable fixing point.

The switch enclosure is conical in shape and the required number of microswitches are cast at predetermined angles inside it. The hermetically sealed float housing is filled with plastic foam and is weighted on one side. This rugged float and the weight are made of chemically resistant polypropylene while the standard cable is PVC coated.

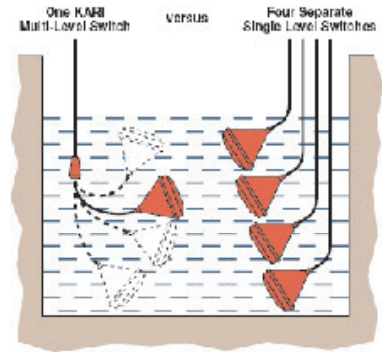

There are three versions of the KA series switch. The standard S Series units are the largest, with a diameter of 6.7 inches, the C Series units have a diameter of 3.9 inches, and the smallest, M series units, are 3.0 inches in diameter.

Alarms				Control Plus Alarms								
Level	IL (1LE)	IH (1HE)	IC	2HL	2L	3L (3LE)	2H	3H (3HE)	4L	4H	4L5E	4H5E
HH	—	—	—	High Alarm	—	—	—	High Alarm			Stop Both Pumps	High Alarm
H	—	—	—	—	Pump Stop		Pump Start		Pump Stop	Pump Start	Start Pump No.1	Start Pump No.2
L	—	—	—	—	Pump Start		Pump Stop		Pump Start	Pump Stop	Start Pump No.2	Start Pump No.1
LL	Low Alarm	High Alarm	High/Low Alarm	Low Alarm	—	Low Alarm	—	—	Low Alarm			Stop Both Pumps
O	Height of Face of Float in Free-Hanging Position											

• **Specifications**

	<b>S Series</b>	<b>C Series</b>	<b>M Series</b>
Contact Rating:			
Max. Voltage	250 V AC/DC	250 V AC/DC	250 V AC/DC
Max. AC Current			
(Resistive)	6 A	6 A	6A
(Inductive)	3 A	3 A	3A
Max. DC Power	75 VA	75 VA	75 VA
(75 VA = 0.3 A @ 250 V)			
Max. liquid Temp	60°C (140°F)	60°C (140°F)	60°C (140°F)
Max. pressure (at 20°C)	28 PSI	28 PSI	28 PSI
Min. Fluid Specific Gravity	0.7	0.7	0.95
Standard Cable Length	16 ft.	16 ft.	16 ft.
Switching Differential:			
Min.	10 in.	10 in.	10 in.
Max.	50 in.	50 in.	40 in.
Max. No. of Switching Levels	4	3	2
Max. No. of wires in Cable	5	4	3
Standard Weight Type	G (black-3/4 lb.)	G (black-3/4 lb.)	B (red-3/4 lb.)

• **Dimensions - in./mm**

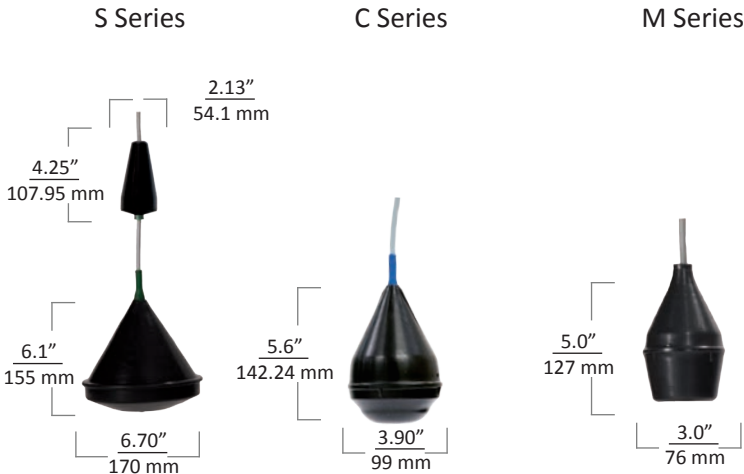

## • Options

- Higher working temperature to 80°C (175°F): Model K
- Longer cables to specified lengths
- Smaller switching differentials down to 1.25 in.
- Greater switching differentials to 75 in. (S series) or 60 in. (M series)
- Alternative logic at switching points (normally open vs. normally closed)
- Alternative cables in rubber and urethane
- Alternative cables in teflon (max. 5 conductors = 4 or less switch points)
- Lead weight in place of polypropylene-covered weight
- Strain Relief Connector, Part #SRCCG

## • Chemical Compatibility — Corrosion Resistance of Materials

With a standard KA float switch, the only materials in contact with the liquid are the polypropylene covered float and weight, the heavy duty PVC coated cable, and the polypropylene wedge. Consequently, these switches are unaffected by a wide range of liquids. However, there are some liquids that are not compatible with these materials. For such applications, alternative construction materials are available as indicated in the Options section above. In assessing corrosion, key factors are the liquid's temperature and concentration, and the amount of time the float is immersed. Even if periodic replacement of KA float switches is necessary, they still may be the most economical choice. Rubber cables are preferred for applications where freezing conditions can occur, because PVC-coated cables tend to stiffen in such situations.

## • Cable Weights

Single level switches (high or low alarm) are not supplied with weights. All multiple level switches are supplied with standard weights. Heavier weights may be needed if there is a danger of caking, thick crusts developing and/or the liquid is very dense and viscous. Alternative weights available are:

Standard: S & C series - Type A (black) 3/4 lb. M series - Type B (red) 1/2 lb.

Special: Type K (black) 1-1/2 lb. Type L (black) 2-1/2 lb.

## • Cable Specifications

Standard units have heavy duty cables with PVC covering. Typical diameters of the cables are:

2-Wires (1L, C1L, M1L, 2L, C2L, M2L, etc.): 0.25 in.

3-Wires (3L, C3L, 3H, C3H, etc.): 0.27 in.

4-Wires (4L, 4H, 3LE, C3LE, etc.): 0.31 in.

5-Wires (4L5E, 4H5E, etc.): 0.34 in.

(Dimensions may vary  $\pm 10\%$ )

An integral cable, without splices, or greater length than the standard 16 feet may be needed for some situations, and this can be supplied by special order. It is not possible to modify the cable length (nor repair damaged cables) on existing units. Once the cable is outside the liquid, it can, however, be easily extended through a waterproof junction box or liquid-tight connector.

• Switch Wiring and Type Detail Table for KA Float Switches

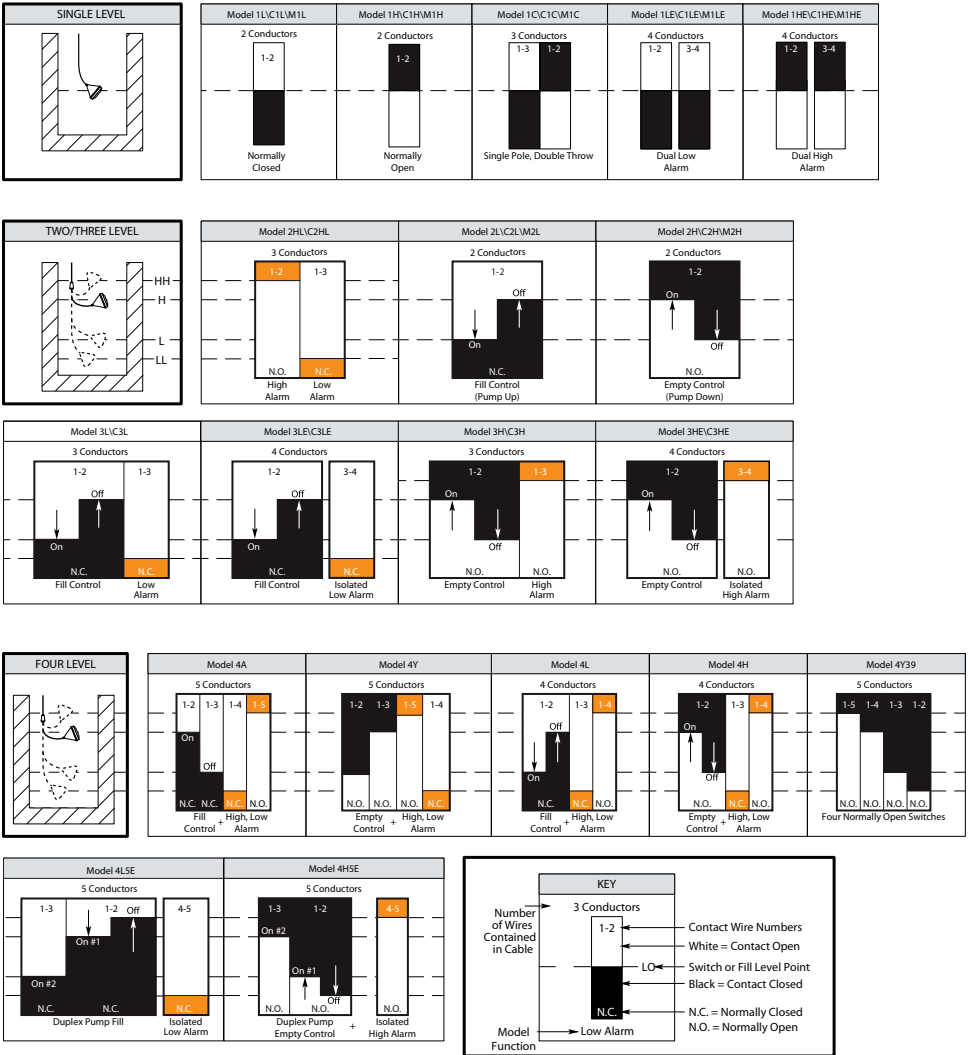



## • Selecting the Right Switch

The following procedure should be used to select the optimum switch or switch combination:

1. Determine the number of control points needed; for example, one point for alarm, two points for empty/fill, etc.
2. Select required model(s) from the Type Detail Table (previous page). If necessary, special switches may be ordered with non-standard switching logic.
3. The smaller, lower cost C series switches may be used if no more than a four conductor cable is needed.
4. The smallest, lowest cost M series switches may be used if the three following conditions are met:
  - a. No solid floating materials are present.
  - b. The specific gravity of the liquid is greater than 0.95.
  - c. No more than a two conductor cable is needed.
5. Note that if a special material compatibility situation exists, there are a number of options available as indicated in the Options section on page 6.

The next several sections describe how the switching levels are related to each other and how they are adjusted. If it is found that the required levels cannot be accommodated by standard units, a special switch can be ordered. For use in still liquids, a two level switch with a smaller differential than the standard minimum (10 inches) may be ordered. Sometimes a combination of switches needs to be used to achieve the required switching heights or range of adjustment capabilities. For example a Model 3HE can be replaced by a model 2H plus a separate model 1H, or a model 2LH by a model 1H plus model 1L. Our Applications Engineering Department is pleased to assist users to select the best models for their particular needs.

## • Understanding the Switch Action/Terminology

In order to understand the operation of KA liquid level controls, imagine them operating like pushbutton switches. A normally open (NO) switch is one that is open when there is no liquid present and closes as the liquid rises. Such a switch is symbolized as in Diagram 1. The opposite action normally closed (NC) switch operates as in Diagram 2. Note that the term “normally” means the switch state when there is *no* liquid present — it does not mean the “usual” operating state of the switch.

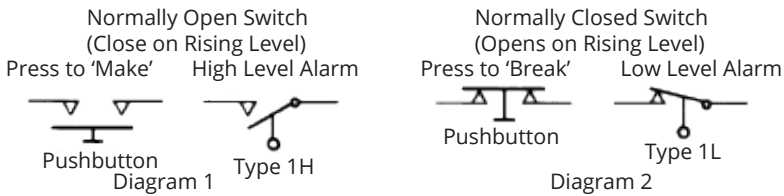

## • Single Versus Dual Point Control

The simplest single level KA float switches (types 1L or 1H) have no deadband (differential or hysteresis). They switch ON and OFF at one level point. Such switches work well as alarm point indicators but are unsuitable for automatic maintenance of the level of liquids in containers.

Usually, tank levels are maintained by pumps or electrically controlled solenoid valves in the supply or drain lines. Holding the level exactly at one point is difficult if there is flow in and out of the container, because it would involve the control switch going on and off constantly. This leads to excessive wear of the components. Thus, the normal practice is to have two control levels involved. At one level the pump or valve is turned ON and at the other level it is turned OFF.

These situations can take advantage of the unique capabilities of the KA float switches. Rather than using two separate single level float switches, one float switch (type 2L or 2H) can provide ON and OFF level controls. The absolute height and separation (deadband) of these points can be easily adjusted. The ON control is a “make” in the circuit and the OFF is a “break” in the circuit. The deadband is supplied by the float switch. Other KA float switches provide additional facilities for high and low alarms as well as control of duplex pump systems.

• **Single Point with Timed Relay Control**

There may be some situations where it is not possible to produce any form of dual level control. In such cases an effective deadband can be produced with a single level switch by using it in conjunction with a time delay relay. When the switch operates, it turns on the relay which stays on for a predetermined period so that the pump or valve operates for that set period each time that it is turned ON.

• **Emptying/Filling Pump Control Circuits**

**Simple Filling (Pump up) Control (Using Type 2L)**

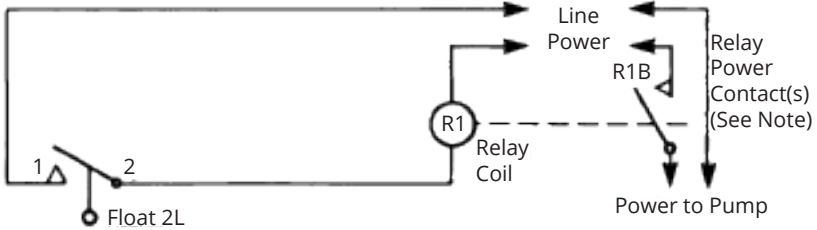

**Simple Emptying (Pump down) Control with High Level Alarm (Using Type 3HE plus manual override)**

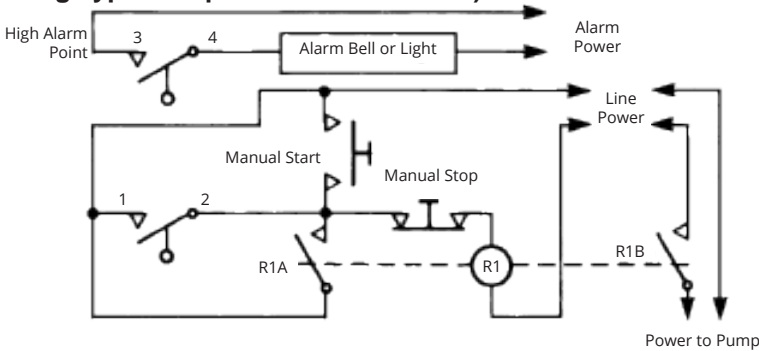

Note: In the above examples, the relay contact R1A is used to electrically latch the relay ON in manual use. If the pump is manually started the float switch will not turn OFF. (The relay/contacter R1 used should be a DPST type with suitable ratings on one contact (R1B) able to carry the voltage and current required by the pump motor horsepower rating. If the pump motor requires three phase power, the relay contact R1B would have to be composed of three poles of heavy duty NO switches capable of carrying the pump motor power as well as there being an auxiliary NO switch contact R1A for latching purposes. Heavy duty relay contactors of this type are readily available at most electrical supply houses.

• Duplex Pump Control Circuit (Using Type 4H5E)

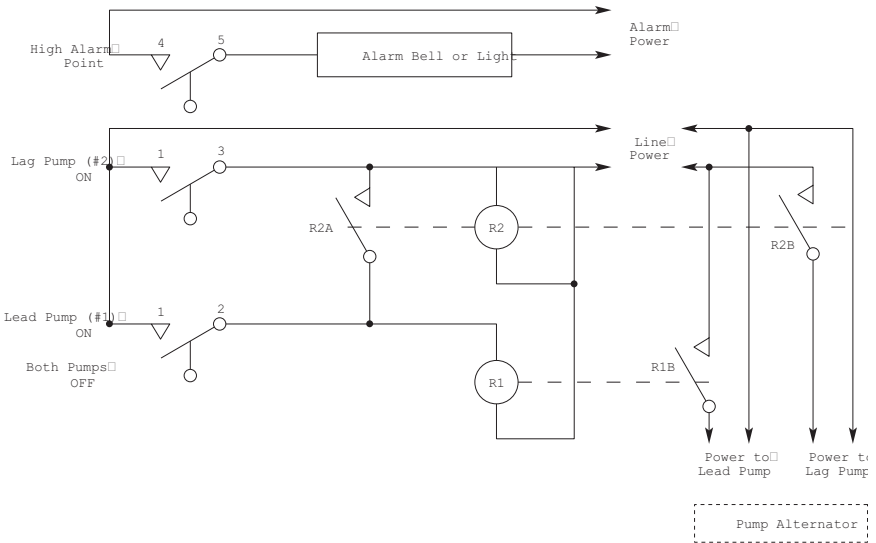

Note: Usually an alternator control is added to the lead and lag pump control circuits. This control automatically alternates the order in which the two pumps come on. In this way the wear on the pumps is evened out. If this is not done, in the course of time, the user will have one (lead) pump that is well worn and one (lag) pump that is barely used. If the pumps use three phase power, the single pole switch contacts, R1B and R2B, would need to be heavy duty three pole switch contacts.

## • Operating Level Adjustment

Switch operating levels depend on the height at which the float is positioned in the tank by the cable fastening and the distance along the cable between the float and the weight. The Termination and Height Fixing section on the next page of this manual discusses the methods for securing the cable at the required height. The height of the face of the float in the free hanging position, with no liquid present, is used as a zero reference for adjusting all switch point operating levels per the graph and diagram below. Level settings may vary slightly between switches. Final adjustments should be made under actual pumping conditions. If there is surface wave motion, some variation in actual switching levels may occur.

For single level types (1L, 1H, 1C, 1LE and 1HE), the float should be hung so that the desired switching point is 5 inches above the zero reference. This represents the difference in height between levels 0 and LL. Note that these single level switches do not require a weight on the cable for their tilting operation.

For multi level types, the distance A (from 0 to weight) must be adjusted to obtain the desired switching differential. For most switches the differential height B between levels H and L is the crucial dimension. The required value for B, together with the corresponding value of A, is selected from the graph shown on the next page. Then, if the weight is wedged at that distance and the float hung in accordance with the diagram, the switch points will operate with the correct differential. The graph gives the distance C between levels H and HH for the determined value of A. It will be seen that switching levels HH and LL bear a specific relationship to A and B and cannot be independently adjusted. Thus, if it is essential to be able to adjust these levels separately, two floats will be required rather than just one.

As a working example, consider a type 4H needing a pump operating differential of 20 inches (= dimension B). From the graph it can be seen that the corresponding value for A is approximately 19 inches. Now suppose that the float is to operate in a tank so that the pump “off” position (level L) is 15 inches from the bottom of the tank. This means that the float must be hung so that the zero reference height (free-hanging face of the float) is 6 inches from the bottom of the tank. The high and low alarm points HH and LL will then be, respectively, close to 41 and 11 inches from the bottom of the tank.

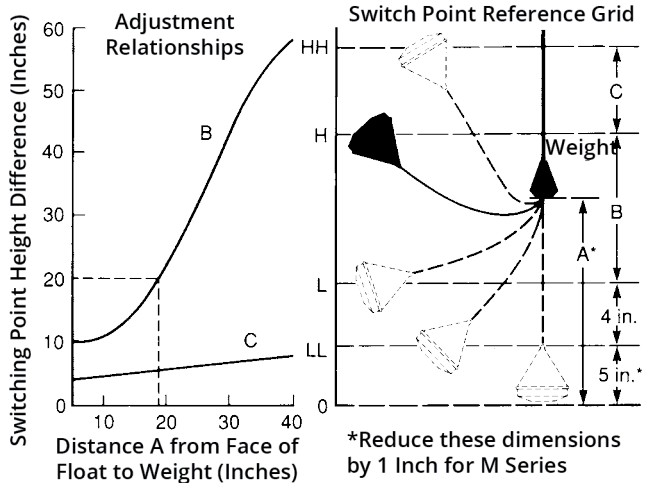

For type 2HL, the difference between the high and low alarm points is the difference between levels LL and HH in the graph. Note that this corresponds to distance B + C + 4 inches and the distance A for weight positioning must be selected accordingly.

**• Termination and Height Fixing**

There are several methods that can be used to fasten the cable so that the float is positioned at the right level in the tank. The three most commonly used are illustrated below. Very frequently, the cable will need to be led into a standard NEMA box with terminals for extension to the control panel. The liquid tight (70 psi) Strain Relief Connector (Part# SRCG) can be used to lead the cable through the wall of the box.

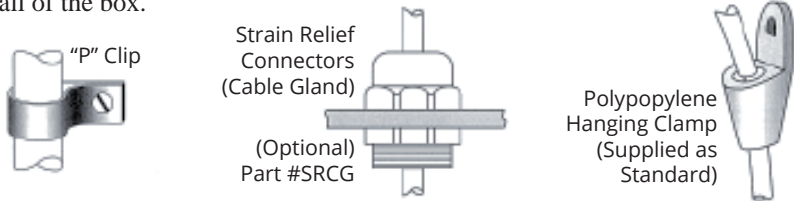

## • Position in Tank/Swing Distance Allowance

KA float switches should hang freely in the tank and not be tightly tethered. If more than one float switch is to be installed in the tank, the cable fixing points should be separated to prevent the cables from tangling. The float switches do not need to be hung in the center of the tank — the cable can run down a wall or corner of the tank as illustrated below.

The float switches need a certain free surface to operate in. As a rule of thumb, the swing radius to be allowed should be the same as the distance of the weight from the bottom of the float. If necessary, baffles or stilling wells may have to be provided to prevent interference with other equipment. Contact our Applications Engineering Department for alternative suggestions if any difficulties in this regard are foreseen or encountered.

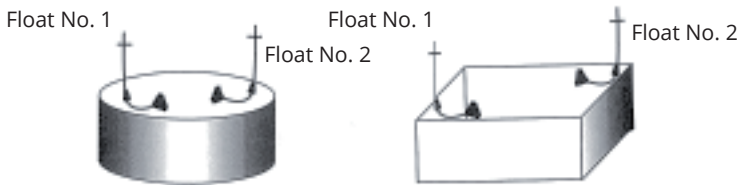

## • Control Contact Ratings

The contacts used in the KA float switches are high performance microswitches. Although they are capable of carrying quite high currents at up to 250 VAC, it is not a good practice to put pump motor currents directly through these contacts because they are immersed in the liquid. Thus, it is usually just low sensing currents for relay coil operation that are applied to the float switch contacts.

Relays with heavy duty contacts are known as contactors. Pump motor manufacturers often provide suitable contactors with control circuits on their motors. These allow the KA float switches to be connected directly. If contactors are not provided, the contact ratings needed to start and stop a pump should be approached with caution: when pump motors start and stop, they can produce a momentary surge current several times greater than the steady running current. Suppliers of the relays and contactors usually provide maximum ratings for their contacts in terms of allowable pump motor horsepower figures. If there are any concerns in this regard, consult our Applications Engineering Department for advice.

## • Verifying Operation

KA float switches are highly reliable. However, if a check on the operation of a particular switch is needed, it is first necessary to ascertain where the bias weight is located in order to find the top point when the float is in the liquid. A good way to do this is to put the float switch on a flat surface so that it can roll freely to the working orientation (just like it does in the liquid). A continuity meter should then be attached to the circuit to be tested. Testing is then performed by tilting the float up and down in the vertical plan determined by the working orientation. At the appropriate angle, the switch circuit being tested should open or close.



**• Valuable Tips**

1. Do not be concerned if you hear a clacking sound when the float is shaken — it is only the microswitch acting. It is extremely unusual to find any leakage in these floats.
2. Do not put the full line power voltage across a contact without a load attached. Shorting out the power across the microswitch will destroy it.
3. Do not tether the floats tightly on a short cable or make them jiggle and dance in a high pressure washdown hose stream. The continuous flexing at a particular point in the cable will break the wires.

## • Certificate of Compliance



# Certificate of Compliance

<b>Certificate:</b>	1358188	<b>Master Contract:</b>	237484
<b>Project:</b>	2721544	<b>Date Issued:</b>	July 24, 2014
<b>Issued to:</b>	Automation Products Group Inc 1025 West 1700 North Logan, UT 84321 USA Attention: Karl Reid		

*The products listed below are eligible to bear the CSA Mark shown with adjacent indicators 'C' and 'US' for Canada and US or with adjacent indicator 'US' for US only or without either indicator for Canada only.*



*Virali Shah*  
Issued by: Virali Shah

### PRODUCTS

**CLASS 3211 86** - INDUSTRIAL CONTROL EQUIPMENT-Motor Controllers - Miscellaneous-Certified to U.S. Standards  
**CLASS 3211 06** - INDUSTRIAL CONTROL EQUIPMENT - Motor Controllers - Miscellaneous

Float switches Model No. KA-C, KA-M and KA-S Series:

Rated 250 Vac, 6 A max (resistive), 3 A max (inductive) or 250 V dc, 0.3 A max.

Note: These devices are Certified as components for use only in other Certified equipment where the suitability of the combination is determined by CSA.

### APPLICABLE REQUIREMENTS

CSA Standard C22.2 No 14-13 - Industrial Control Equipment  
 ANSI/UL 508 (17th Edition) - Industrial Control Equipment

# AUTOMATION

PRODUCTS  
GROUP, INC.

## Operator's Manual



Automation Products Group, Inc.

*APG...Providing tailored solutions for measurement applications*

Tel: 1/888/525-7300 • Fax: 1/435/753-7490 • [www.apgsensors.com](http://www.apgsensors.com) • E-mail: [sales@apgsensors.com](mailto:sales@apgsensors.com)