

MPX Magnetostrictive Level Sensors User Manual

For The MPX-E and MPX-R

Table of Contents

Introduction	iii
Warranty and Warranty Restrictions	iv
Chapter 1: Specifications and Options.....	1
Dimensions	1-2
Specifications	3
Model Number Configurator.....	4
Electrical Connections and System Wiring Diagrams	5-6
Chapter 2: Installation and Removal Procedures and Notes.....	7
Tools Needed.....	7
Physical Installation	7
Electrical Installation	8
Removal Instructions	8
Chapter 3: Programming	9
Modbus Programming	9
Modbus Programming with RST-6001 and APG Modbus Software	9
4-20 mA Programming with RST-4100 and APG Modbus Software.....	10
Modbus Register Lists	10
Chapter 4: Maintenance	11
General Care	11
Repair and Returns.....	11
Chapter 5: Hazardous Location Installation and Certification.....	12
Hazardous Location and Non-Incendive Wiring Diagram.....	12
CSA Certificate of Compliance	13-16

Introduction

Thank you for purchasing an MPX series magnetostrictive level sensor from APG. We appreciate your business and your trust. Please take a few minutes to familiarize yourself with your MPX and this manual.

The MPX level sensor provides highly accurate and repeatable level readings in a wide variety of liquid level measurement applications. It is certified for installation in hazardous areas in the US and Canada by CSA for Class I, Division 1 & 2 and Class I, Zones 1 and 2 environments. The MPX-R's large, bouyant, and robust floats allow it to be used in harsh applications where fouling or buildup might otherwise be of concern. The smaller, lighter weight floats of the MPX-E allow it to be used in applications where space is limited.

Reading your label

Every APG instrument comes with a label that includes the instrument's model number, part number, and serial number. Please ensure that the part number on your label matches your order. The following electrical ratings and approvals are also listed on the label. Please refer to the Certificate of Compliance at the back of this manual for further details.

Electrical ratings



Input: 12 - 24 VDC; Output: 4-20 mA / 80 mA
Class I, Division 1 & 2, Groups C, and D
Ex d IIB
Ex nA IIB
Class I, Zone 1; AEx d IIB
Class I, Zone 2; AEx na IIB

Non-Incendive Wiring Requirements: $V_{max} = 26VDC$, $I_{max} = 200mA$, $C_i = 0nF$, $L_i = 0\mu H$

i IMPORTANT: MPX level sensor MUST be installed according to drawing 9003468 (Hazardous Installation and Non-Incendive Wiring Drawing) on page 12 to meet listed approvals. Faulty installation will invalidate all safety approvals and ratings.

Warranty and Warranty Restrictions

APG warrants its products to be free from defects of material and workmanship and will, without charge, replace or repair any equipment found defective upon inspection at its factory, provided the equipment has been returned, transportation prepaid, within 24 months from date of shipment from factory.

THE FOREGOING WARRANTY IS IN LIEU OF AND EXCLUDES ALL OTHER WARRANTIES NOT EXPRESSLY SET FORTH HEREIN, WHETHER EXPRESSED OR IMPLIED BY OPERATION OF LAW OR OTHERWISE INCLUDING BUT NOT LIMITED TO ANY IMPLIED WARRANTIES OF MERCHANTABILITY OR FITNESS FOR A PARTICULAR PURPOSE.

No representation or warranty, express or implied, made by any sales representative, distributor, or other agent or representative of APG which is not specifically set forth herein shall be binding upon APG. APG shall not be liable for any incidental or consequential damages, losses or expenses directly or indirectly arising from the sale, handling, improper application or use of the goods or from any other cause relating thereto and APG's liability hereunder, in any case, is expressly limited to the repair or replacement (at APG's option) of goods.

Warranty is specifically at the factory. Any on site service will be provided at the sole expense of the Purchaser at standard field service rates.

All associated equipment must be protected by properly rated electronic/electrical protection devices. APG shall not be liable for any damage due to improper engineering or installation by the Purchaser or third parties. Proper installation, operation and maintenance of the product becomes the responsibility of the user upon receipt of the product.

Returns and allowances must be authorized by APG in advance. APG will assign a Return Material Authorization (RMA) number which must appear on all related papers and the outside of the shipping carton. All returns are subject to the final review by APG. Returns are subject to restocking charges as determined by APG's "Credit Return Policy".

Chapter 1: Specifications and Options

- **Dimensions**

MPX-E Sensor and Float Dimensions

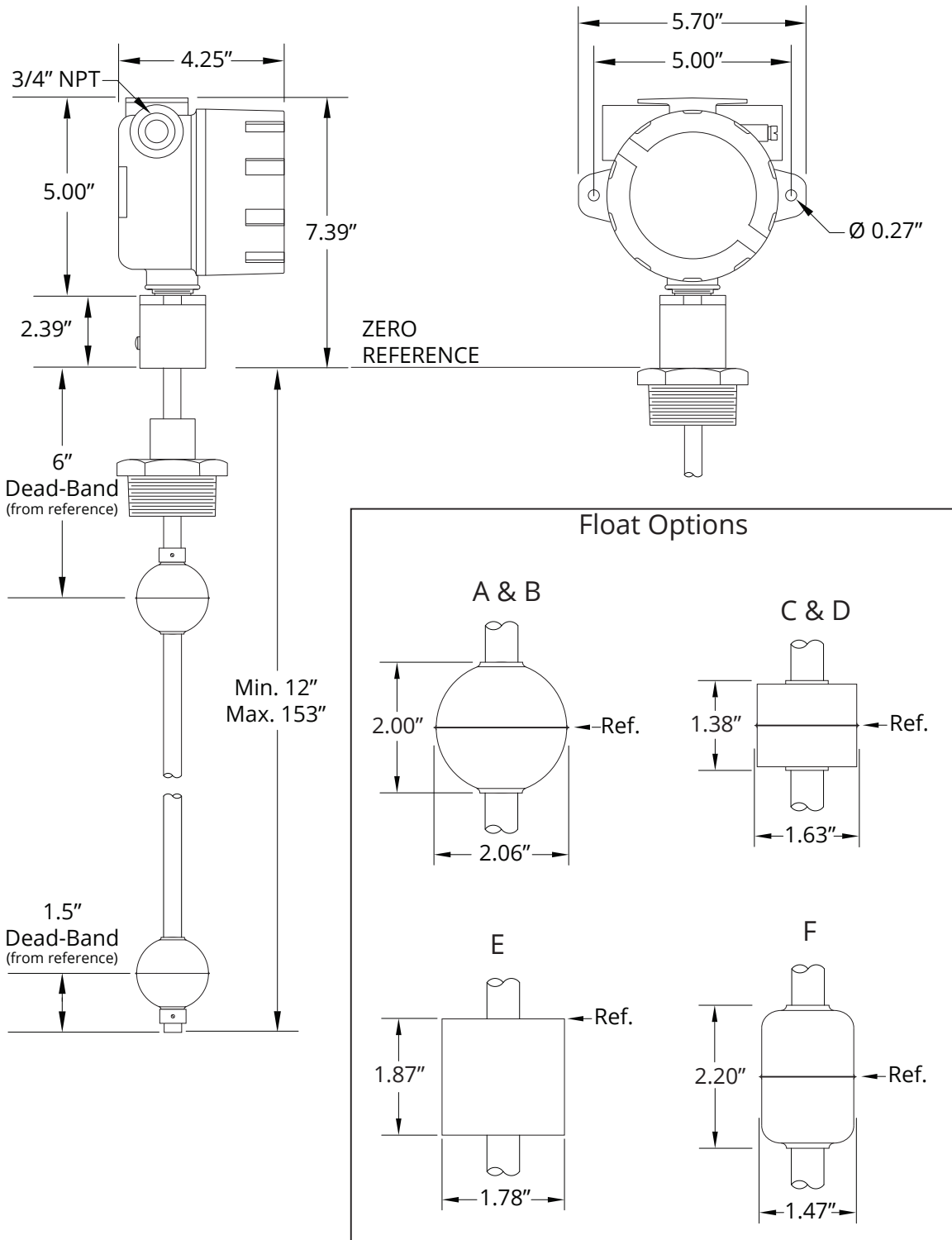

MPX-R Sensor and Float Dimensions

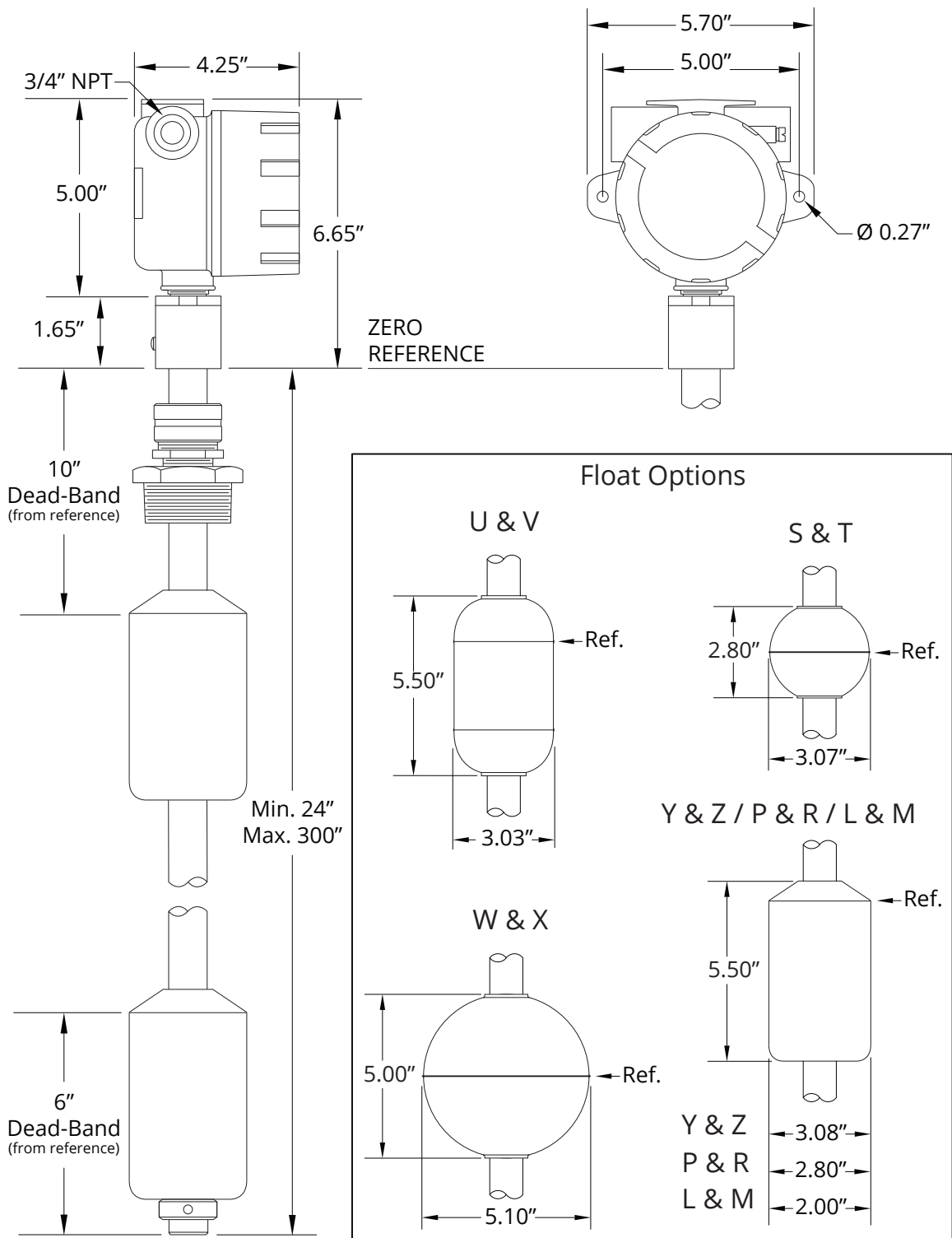

• Specifications

Performance

Resolution	4-20 mA: 14 bit DAC
Accuracy	Modbus: 0.04 in. (1 mm) ±0.05% of Full Scale

Environmental

Operating Temperature	-40 to 85°C	(-40 to 185°F)
Enclosure Protection	NEMA 4X, IP65	

Electrical

Supply Voltage	12-24 VDC on sensor
Current Draw	4-20 mA: 22 mA single / 44 mA dual Modbus (RS-485): 25 mA (MPX-E) 28 mA (MPX-R)

Materials of Construction

Housing	Cast aluminum, epoxy coated
Stem	304 SS or 316L SS

Connectivity

Output	2 wire, loop-powered 4-20 mA 3 wire, loop-powered dual 4-20 mA Modbus RTU (RS-485)
--------	--

Programming

RS-485	Optional RST-6001 USB-to-RS-485 converter
4-20 mA	Optional RST-4100 programming module

- **Electrical Connections and System Wiring Diagrams**

Modbus System Wiring

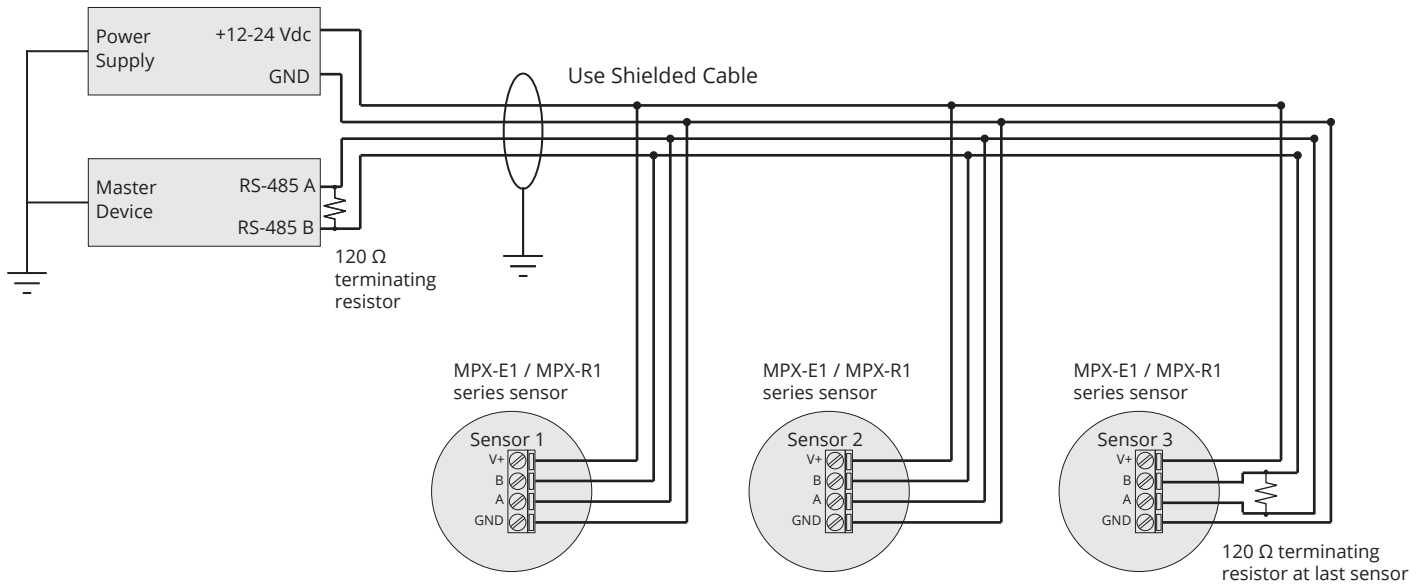

Modbus System Wiring with RST-6001

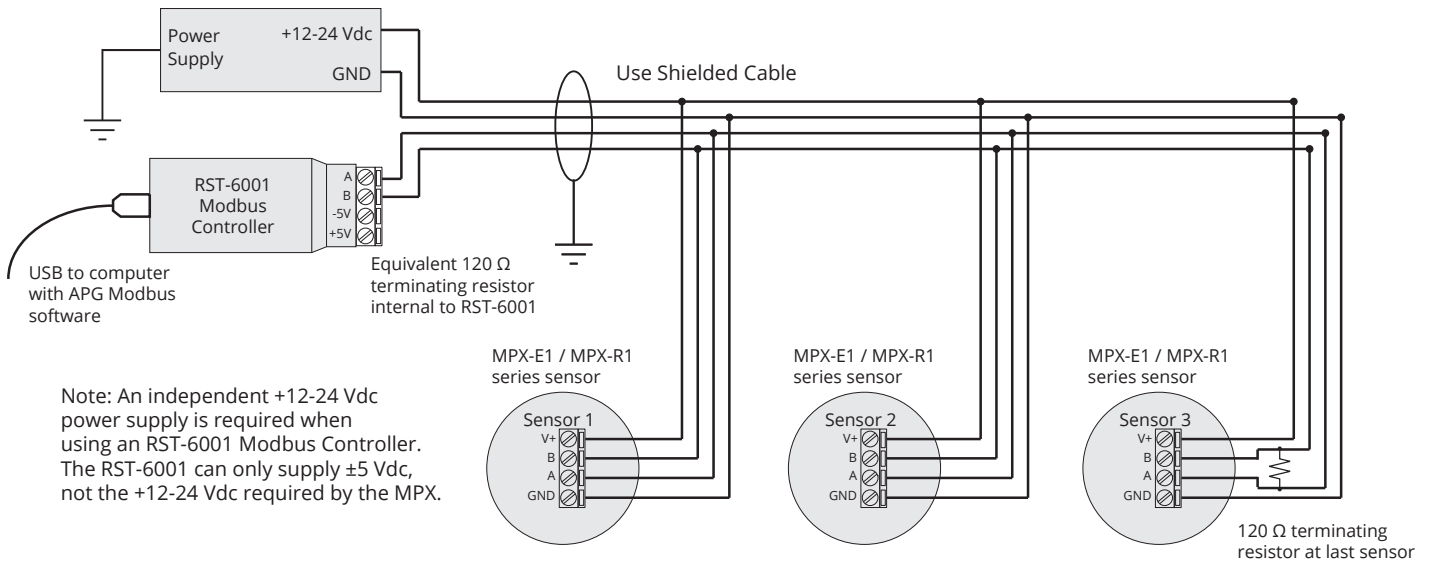

i IMPORTANT: Refer to Chapter 5 for Hazardous Location and Non-Incendive Wiring diagrams.

4-20 mA Loop Wiring

4-20 mA Single Float Loop Wiring
(MPX-E2 and MPX-R2 Series)

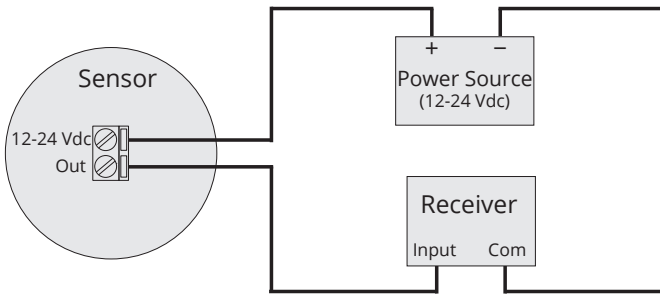

4-20 mA Dual Float Loop Wiring
(MPX-E3 and MPX-R3 Series)

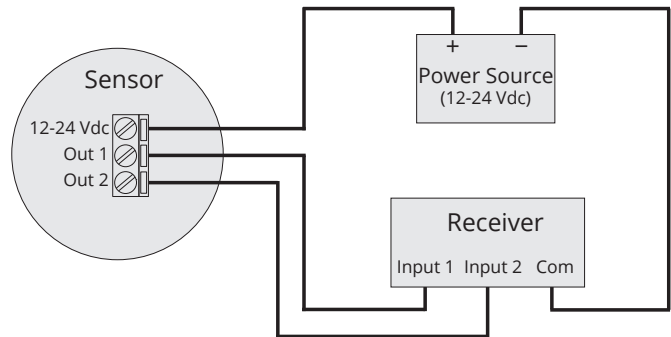

i IMPORTANT: Refer to Chapter 5 for Hazardous Location and Non-Incendive Wiring diagrams.

OR

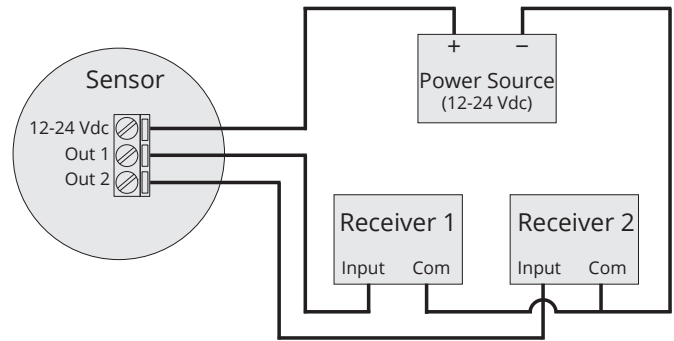

4-20 mA Programming Wiring

Programming configuration is for programming ONLY. After programming, sensor must be reintegrated to 4-20 mA loop for proper system operation.

USB to computer with APG Modbus software

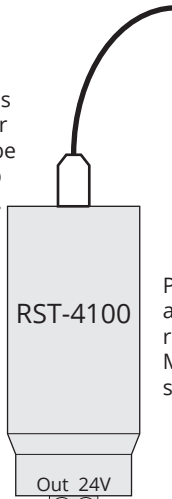

Programming Module and APG Modbus software required for programming MPX-E2,3 and MPX-R2,3 series sensors.

MPX-E2/R2 or MPX-E3/R3 series sensor.

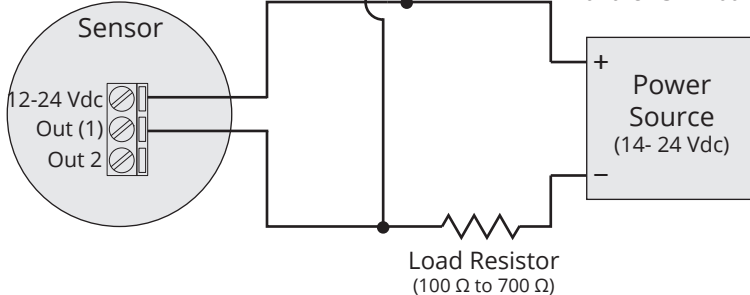

Note: a minimum of 14 Vdc is required to establish communications with the RST-4100

NOTE: For MPX-E3/R3 series sensors, - Vdc from power source must be connected to Output1 on sensor through a Load Resistor for correct sensor programming.

Chapter 2: Installation and Removal Procedures and Notes

• Tools Needed

You will need the following tools to install your MPX level sensor:

- Wrench

• Physical Installation Notes

The MPX should be installed in an area--indoors or outdoors--which meets the following conditions:

- Ambient temperature between -40°C and 85°C (-40°F to +185°F)
- IEC-664-1 Conductive Pollution Degree 1 or 2
- No corrosive gases such as NH₃, SO₂, Cl₂, etc.
- Ample space for maintenance and inspection

Additional care must be taken to ensure:

- The probe is located away from strong magnetic fields, such as those produced by motors, transformers, solenoid valves, etc.
- The medium is free from metallic substances and other foreign matter.
- The probe is not exposed to excessive vibration.
- The float(s) fit through the mounting hole. If the float(s) does/do not fit, it/they must be mounted on the stem from inside the vessel being monitored.
- The float(s) is/are oriented properly on the stem (See Figure 2.1 below). MPX-E floats will be installed by the factory. MPX-R floats are typically installed by customer.

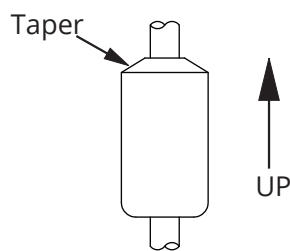

Figure 2.1

• Physical Installation Instructions

- If your sensor's stem and floats fit through the mounting hole, carefully lower the assembly into the vessel, then secure the sensor to the vessel.
- If the floats do not fit, mount them on the stem from inside the vessel being monitored. Then secure the sensor to the vessel.

i IMPORTANT: Floats must be oriented properly on the stem, or sensor readings will be inaccurate and unreliable.

• **Electrical Installation**

- Remove the housing cover of your MPX.
- Feed system wires into MPX through 3/4" NPT conduit openings.
- Connect wires to MPX terminals.
- Replace the housing cover.

See Electrical Connections and System Wiring Diagrams (pages 5 and 6) for Modbus and 4-20 mA wiring examples.

• **Removal Instructions**

Removing your MPX level sensor from service should be done with care.

- If the floats on your sensor fit through the mounting hole, carefully lift the entire sensor assembly out of and away from the vessel.
- If the floats on your sensor do not fit through the mounting hole, they will need to be removed from the stem before the sensor can be removed. Be sure to drain the vessel being monitored to allow access to the floats and stem for removal.
- Clean the stem and floats of any build up or debris and inspect for damage.
- Store your sensor in a dry place, at a temperature between -40° F and 180° F.

Chapter 3: Programming

• **Modbus Programming**

MPX-E1 and MPX-R1 series sensors use standard Modbus RTU protocol (RS-485). The sensors can only operate as slave devices. Sensor default transmission settings are **9600 Baud, 8 Bits, 1 Stop Bit, No Parity**, and require a minimum delay of 300 ms between transactions. See MPX Modbus Register Lists on pages 9 and 10.

 **NOTE:** For more information about Modbus RTU, please visit www.modbus.org.

• **Modbus Programming with RST-6001 and APG Modbus Software**

APG RST-6001 Modbus Controller can be used in tandem with APG Modbus to program and control up to 20 MPX-E1 or MPX-R1 series sensors. Through APG Modbus, you can monitor the raw readings from the sensor, configure the data for distance, level, volume, or weight, and enter measurements for a strapping chart. See MPX Modbus Register Lists on pages 9 and 10.

 NOTE: For APG Modbus programming instructions, or to download APG Modbus software, please visit www.apgsensors.com/support.

- **4-20 mA Programming with RST-4100 and APG Modbus Software**

APG RST-4100 Programming Module can be used in tandem with APG Modbus to program a single MPX-E2/3 or MPX-R2/3 series sensor. Through APG Modbus, you can configure the 4 mA and 20 mA output setpoints and sensor sensitivity settings. If your monitoring equipment (PLC, etc.) can be configured to interpret the 4-20 mA output(s) of the MPX as volume or weight, then the MPX can be configured accordingly via APG Modbus.

However, the RST-4100 is not designed to be used for continuous monitoring of a sensor. After programming your MPX sensor, the RST-4100 must be removed and the wiring returned to normal. See 4-20 mA Loop Wiring and 4-20 mA Programming Wiring on page 6.

- **APG Modbus Register Lists**

Input Registers (0x04)

<u>Register</u>	<u>Returned Data</u>
30300	Raw Top Float Reading (in mm, unsigned)
30301	Raw Bottom Float Reading (in mm, unsigned)
30302	Temperature Reading (in °C, signed) [MPX-R; Optional on MPX-E]
30303-30304	Calculated Top Float Reading (in selected Units)
30305-30306	Calculated Bottom Float Reading (in selected Units)

 NOTE: The Calculated Readings will be returned without a decimal place. In order to obtain the true result, the Decimal Place setting must be taken into account.

Holding Registers (0x03)

<u>Register</u>	<u>Function</u>	<u>Value Range</u>
40400	Device Address	1 to 255
40401	Units	1 to 3
40402	Application Type	0-10
40403	Volume Units	0 to 6
40404	Decimal Place	0 to 3
40405	Max Distance	0 to 10364 mm
40406	Full Distance	0 to 10364 mm
40407	Empty Distance	0 to 10364 mm
40408	Sensitivity	0 to 100
40409	Pulses	0 to 20
40410	Blanking	0 to 10364 mm
40411	Reserved	n/a
40412	Averaging	0 to 100
40413	Filter Window	0 to 10364 mm
40414	Out of Range Samples	0 to 255
40415	Sample Rate	50 to 1000 msec.
40416	Multiplier	1 to 1999
40417	Offset	+/- 10364 mm
40418-40420	Reserved	n/a
40421	RTD Offset (°C)	-100 to 100
40422	Float Window	0 to 1000 mm
40423	Top Float Offset	-10364 to 10364
40424	Bottom Float Offset	-10364 to 10364
40425	Gain Offset	0 to 255
40426	4 mA Set Point	0 to 10364 mm
40427	20 mA Set Point	0 to 10364 mm
40428	4 mA Calibration	0 to 1000
40429	20 mA Calibration	0 to 1000
40430	Web Alarm 1 Distance	
40431	Web Alarm 1 Window	
40432	Web Alarm 1 Type	
40433	Web Alarm 2 Distance	
40434	Web Alarm 2 Window	
40435	Web Alarm 2 Type	
40436-40437	Parameter 1 Data	0 to 100,000 mm
40438-40439	Parameter 2 Data	0 to 100,000 mm
40440-40441	Parameter 3 Data	0 to 100,000 mm
40442-40443	Parameter 4 Data	0 to 100,000 mm
40444-40445	Parameter 5 Data	0 to 100,000 mm

Chapter 4: Maintenance

- **General Care**

Your MPX level sensor is designed to be low maintenance. However, in general, you should:

- Periodically inspect your MPX to ensure the stem and floats are free of any heavy buildup that might impede the movement of the floats.
- Ensure the housing cover is snugly secured. If the cover becomes damaged or is misplaced, order a replacement immediately.

- **Repair and Returns**

Should your MPX level sensor require service, please contact the factory via phone, email, or online chat. We will issue you a Return Material Authorization (RMA) number with instructions.

- Phone: 888-525-7300
- Email: sales@apgsensors.com
- Online chat at www.apgsensors.com

Please have your part number and serial number available. See Warranty and Warranty Restrictions for more information.

i **IMPORTANT:** All repairs and adjustments of the MPX level sensor must be made by the factory. Modifying, disassembling, or altering the MPX on site is strictly prohibited.



Certificate: 2397437

Master Contract: 237484

Project: 2397437

Date Issued: May 18, 2011

Notes:

- The model code breakdown is as follows: a= E or R; b= 1, 2 or 3; c= A, B, C, D, E, F, Z, or Y; d= N, B, D, or Y; e= F, R, P, N, or O; f= W or S; g= A or B; and hhh= 12–153 for the 1/2" stem or 48–300 for the 1" stem.
- The equipment is intended to be installed as required by the applicable electrical code (CEC, NEC) and as specified by the manufacturers Installation Instructions.
- The installation will be inspected by the authority with jurisdiction in the area where installed.

APPLICABLE REQUIREMENTS

CSA C22.2 No 0-10	General Requirements – Canadian Electrical Code, Part II – Tenth Edition
CSA C22.2 No 30-M1986 (R 2007)	Explosion-Proof Enclosures for Use in Class I Hazardous Locations Industrial Products – Third Edition
CSA C22.2 No 142-M1987 (R 2009)	Process Control Equipment Industrial Products – Third Edition
CSA C22.2 No 213-M1987 (R 2008)	Non-incendive Electrical Equipment for Use in Class I, Division 2 Hazardous Locations Industrial Products – First Edition
CSA C22.2 No 60079-0-07	Electrical apparatus for explosive gas atmospheres – Part 0: General requirements – First Edition
CSA C22.2 No 60079-1-07	Electrical apparatus for explosive gas atmospheres – Part 1: Flameproof enclosures "d" – First Edition
CSA E60079-15-02 (R 2006)	Electrical Apparatus for Explosive Gas Atmospheres – Part 15: Type of Protection "n" – Second Edition
UL 508	Industrial Control Equipment - Seventeenth Edition; Reprint with Revisions Through and Including April 15, 2010
UL 1203	Explosion-Proof and Dust-Ignition-Proof Electrical Equipment for Use in Hazardous (Classified) Locations - Fourth Edition; Reprint with Revisions through and Including October 28, 2009
ANSI/ISA-12.12.01-2007	Nonincendive Electrical Equipment for Use in Class I and II, Division 2 and Class III, Divisions 1 and 2 Hazardous (Classified) Locations

MARKINGS

The following markings are provided on a UL Recognized (PGJ12) adhesive nameplate manufactured by Datamax, type FantaStock-HCW, printed with a resin ribbon manufactured by Datamax, type Greatribbon SDR or SDR-5, which is suitable for indoor/outdoor use on polyurethane paint coatings, at a maximum service temperature of 135°C or higher. Alternatively a screw or rivet secured metal nameplate or other permanent



Certificate: 2397437

Master Contract: 237484

Project: 2397437

Date Issued: May 18, 2011

manner can be used. The nameplate is affixed to the top of the enclosure. Labels, if shown in the report, may vary slightly in layout, provided that the required information continues to be shown.

The following markings appear on each product where applicable:

- Manufacturer's name: "Automation Products Group", or CSA Master Contract Number "237484", adjacent to the CSA Mark in lieu of manufacturer's name.
- Model number: As specified in the PRODUCTS section, above.
- Electrical ratings: As specified in the PRODUCTS section, above.
- Ambient temperature rating: As specified in the PRODUCTS section, above.
- Manufacturing date in MMY format, or serial number, traceable to month of manufacture.
- Enclosure ratings: As specified in the PRODUCTS section, above.
- The CSA Mark with or without "C" and "US" indicators, as shown on the Certificate of Conformity.
- Hazardous Location designation: As specified in the PRODUCTS section, above (may be abbreviated).
- Temperature code: As specified in the PRODUCTS section, above.
- The name or mark of the certificate issuer and the certificate reference in the following form: the last two figures of the year of the certificate followed by the serial number of the certificate in that year.
- The following words:
 - "OPEN CIRCUIT BEFORE REMOVING COVER" or "KEEP COVER TIGHT WHILE CIRCUITS ARE ALIVE".
 - "WARNING – EXPLOSION HAZARD - Substitution of components may impair suitability for Class I, Division 2."
 - "WARNING – EXPLOSION HAZARD – Do not connect while circuit is live unless area is known to be nonhazardous."
 - "Install per drawing 9003468 (as appropriate for nonincendive field wiring only)."

An installation manual or data sheet shall be supplied with each unit, containing the following minimum marking information:

General: Technical specifications, instructions for use and details of where technical assistance may be obtained if required.

Equipment Ratings: This includes equipment supply, description of I/O connections, duty cycle and operating environmental conditions.

- Pollution degree 2;
- Measurement category II;
- Altitude 2000 m;
- Humidity 0 to 100%;
- Electrical supply DC,
- Indoor and outdoor use statement;
- Temperature - 40°C to 85°C;

Equipment Installation: This includes instructions for assembly and mounting, location requirements, details for special services (cooling supply, etc.) as applicable.



Certificate: 2397437

Master Contract: 237484

Project: 2397437

Date Issued: May 18, 2011

PERMANENTLY CONNECTED EQUIPMENT requires the special considerations to satisfy the CEC and the Canadian deviations in the standard, including overcurrent and fault protection as required.

Equipment Operation: This includes explanations of operating controls and warning symbols used, and instructions for interconnection, replacement of consumables (e.g. paper) and cleaning as required.

Equipment Maintenance: This includes instructions for preventative maintenance, inspection and cleaning, replacement of parts, etc.

Note - Jurisdictions in Canada may require these markings to also be provided in French language. It is the responsibility of the manufacturer to provide bilingual marking, where applicable, in accordance with the requirements of the Provincial Regulatory Authorities. It is the responsibility of the manufacturer to determine this requirement and have bilingual wording added to the "Markings".



Automation Products Group, Inc.

Tel: 1/888/525-7300 • Fax: 1/435/753-7490 • www.apgsensors.com • sales@apgsensors.com