

Solid State Relays Industrial, 1-Phase ZS (IO) w. LED and Built-in Varistor Type HPR48

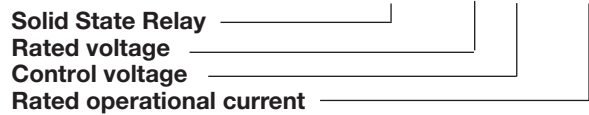

- Zero switching
- Direct copper bonding (DCB) technology
- LED indication
- Built-in varistor 480 V
- Clip-on IP 20 protection cover
- Self-lifting terminals
- Housing free of moulding mass
- 2 input ranges: 4-32 VDC and 20-280 VAC/22-48 VDC
- Operational ratings: Up to 75 AMPS rms
- Rated voltage: 480 VAC rms
- Blocking voltage: 1200V_p
- Opto-isolation: > 4000VAC rms

Ordering Key **HPR 48 A 25**



Product Description

The industrial, 1-phase relay with antiparallel thyristor output is the most widely used industrial SSR due to its multiple application possibilities. The relay can be used for resistive, inductive and capacitive loads. The zero switching relay switches ON when the sinusoidal curve crosses zero and switches OFF when the current crosses zero. The instant-on relay

with DC control input can be used for phase control. The built-in varistor secures transient protection for the heavy industrial applications, and the LED indicates the status of the control input. The clip-on cover is securing touch protection to IP 20. Protected output terminals can handle cables up to 16mm².

Type Selection

Control voltage	Rated operation current
A: 20-280VAC/22-48VDC	25: 25 AMPS rms
D: 4-32VDC	50: 50 AMPS rms
	75: 75 AMPS rms

Selection Guide

Rated operational voltage	Blocking voltage	Control voltage	Rated operational current		
			25A	50A	75A
480 VAC rms	1200V _p	4 - 32VDC	HPR48D25	HPR48D50	HPR48D75
		20 to 280 VAC 22 to 48 VDC	HPR48A25	HPR48A50	HPR48A75

General Specifications

	HPR48...
Operational voltage range	42 to 530 VAC rms
Blocking voltage	≥ 1200V _p
Zero voltage turn-on	≤ 10V
Operational frequency range	45 to 65Hz
Power factor	> 0.5 @ 480 VAC rms
Approvals	cULus
CE-marking	Yes

Input Specifications

	HPR..D..	HPR..A..
Control voltage range		
HPR48...	4 - 32 VDC	20 - 280 VAC 22 - 48 VDC
Pick-up voltage @ Ta = 25°C		
HPR48...	3.5 VDC	18 VAC/DC
Reverse voltage	32 VDC	-
Drop out voltage	1.2 VDC	6 VAC/DC
Input current @ max input voltage		
HPR.....	≤ 12 mA	≤ 20 mA
Response time pick-up		
HPR.....	≤ 1/2 cycle	≤ 12 ms
Response time drop-out		
HPR.....	≤ 1/2 cycle	≤ 40 ms



Output Specifications

	HPR...25	HPR...50	HPR...75
Rated operational current AC51 @ ta=25°C AC53a @ Ta=25°C	25 AMPS rms 5 AMPS rms	50 AMPS rms 15 AMPS rms	75 AMPS rms 20 AMPS rms
Min. operational current	150 mA	250 mA	400 mA
Rep. overload current t=1 s	< 55 AMPS rms	< 125 AMPS rms	<150 AMPS rms
Non-rep. surge current t=10 ms	325A _p	600A _p	1150A _p
Off-state leakage current @ rated voltage and frequency	< 3mA rms	< 3mA rms	< 3mA rms
I² t for fusing t=10 ms	< 525A ² s	< 1800A ² s	< 6600A ² s
On-state voltage drop @ rated current	1.6V rms	1.6V rms	1.6V rms
Critical dV/dt off-state min.	1000V/μs	1000V/μs	1000V/μs

Thermal Specifications

	HPR...25	HPR...50	HPR...75
Operating temperature range	-20° to 70°C (36° to 126°F)	-20° to 70°C (36° to 126°F)	-20° to 70°C (36° to 126°F)
Storage temperature range	-40° to 100°C (72° to 180°F)	-40° to 100°C (72° to 180°F)	-40° to 100°C (72° to 180°F)
Junction temperature	≤ 125°C (225°F)	≤ 125°C (225°F)	≤ 125°C (225°F)
R_{th} junction to case	≤ 0.80K/W	≤ 0.50K/W	≤ 0.35K/W
R_{th} junction to ambient	≤ 20.0K/W	≤ 20.0K/W	≤ 20.0K/W

Housing Specifications

Weight 25A, 50A 75A	Approx. 60g (2.2 Ounces) Approx. 100g (3.6 Ounces)
Housing material	Noryl GFN 1, black
Baseplate 25A, 50A 75A	Aluminium Copper, nickel-plated
Potting compound	None

Housing Specifications (Cont.)

Relay Mounting screws Mounting torque	M5 1.5-2.0 Nm (13-18 in lbs)
Control terminal Mounting screws Mounting torque	M3 x 9 0.5 Nm (4.4 in lbs)
Power terminal Mounting screws Mounting torque	M5 x 9 2.4 Nm (21 in lbs)

Functional Diagram

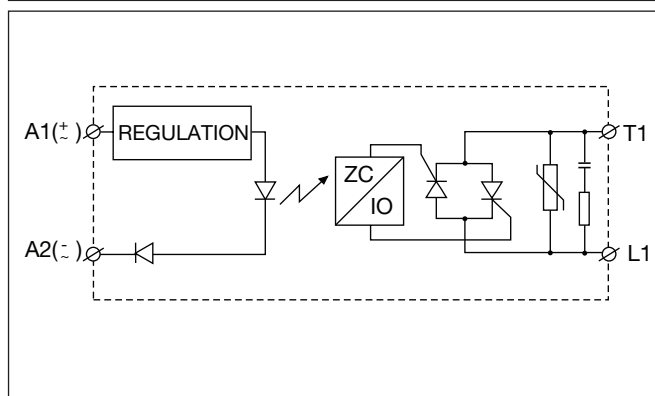

Dimensions

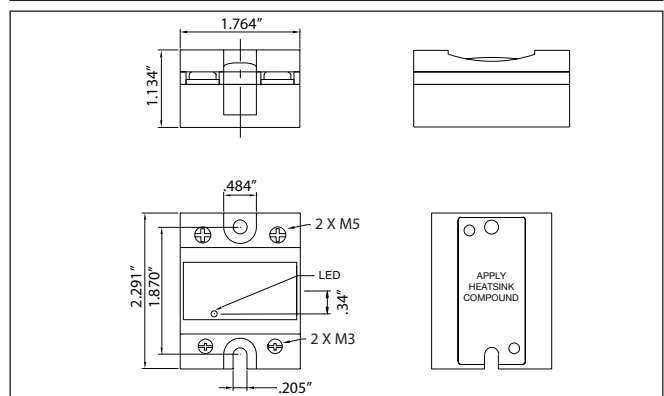



Heatsink Data (load current versus ambient temperature)

HPR...25

Load current [A]	Thermal resistance [K/W]						Power dissipation [W]
	20	30	40	50	60	70°C	
	68	86	104	122	140	158°F	T _A Ambient temp.
25.0	2.70	2.34	1.98	1.61	1.25	0.89	28
22.5	3.10	2.69	2.28	1.86	1.45	1.04	24
20.0	3.61	3.13	2.65	2.18	1.70	1.23	21
17.5	4.26	3.70	3.14	2.59	2.03	1.47	18
15.0	5.14	4.47	3.80	3.14	2.47	1.80	15
12.5	6.38	5.56	4.73	3.91	3.09	2.27	12
10.0	8.25	7.19	6.14	5.08	4.02	2.97	9
7.5	11.4	9.94	8.49	7.04	5.59	4.14	7
5.0	17.7	15.4	13.2	11.0	8.74	6.51	4
2.5	-	-	-	-	18.2	13.6	2

Junction to ambient thermal resistance, R _{th j-a}	< 20.0	K/W
Junction to case thermal resistance, R _{th j-c}	< 0.80	K/W
Case to heatsink thermal resistance, R _{th c-s}	< 0.20	K/W
Maximum allowable case temperature	100 (212)	C (F)
Maximum allowable junction temperature	125 (257)	C (F)

HPR...50

Load current [A]	Thermal resistance [K/W]						Power dissipation [W]
	20	30	40	50	60	70°C	
	68	86	104	122	140	158°F	T _A Ambient temp.
50.0	1.03	0.86	0.70	0.53	0.37	0.20	61
45.0	1.27	1.09	0.90	0.71	0.52	0.33	53
40.0	1.54	1.32	1.10	0.89	0.67	0.45	46
35.0	1.85	1.59	1.34	1.08	0.82	0.57	39
30.0	2.26	1.95	1.65	1.34	1.03	0.72	33
25.0	2.85	2.47	2.08	1.70	1.32	0.94	26
20.0	3.73	3.24	2.75	2.26	1.77	1.27	20
15.0	5.22	4.54	3.86	3.19	2.51	1.83	15
10.0	8.21	7.16	6.11	5.05	4.00	2.95	10
5.0	17.2	15.0	12.9	10.7	8.51	6.33	5

Junction to ambient thermal resistance, R _{th j-a}	< 20.0	K/W
Junction to case thermal resistance, R _{th j-c}	< 0.50	K/W
Case to heatsink thermal resistance, R _{th c-s}	< 0.20	K/W
Maximum allowable case temperature	100 (212)	C (F)
Maximum allowable junction temperature	125 (257)	C (F)

Isolation

Rated isolation voltage ≥ 4000 VAC rms
Input to output

Rated isolation voltage ≥ 4000 VAC rms
Output to case

Heatsink Selection

Heatsink	Thermal resistance...	...for power dissipation
No heatsink required	---	N/A
HS 45CD	2.70K/W	> 60W
HS 45BD	2.00K/W	> 60W
Consult MDI	> 0.25K/W	N/A
Infinite heatsink-No solution	---	N/A

HPR...75

Load current [A]	Thermal resistance [K/W]						Power dissipation [W]
	20	30	40	50	60	70°C	
	68	86	104	122	140	158°F	T _A Ambient temp.
75.0	0.91	0.78	0.65	0.52	0.39	0.26	77
67.5	1.10	0.96	0.81	0.66	0.51	0.36	68
60.0	1.34	1.17	1.00	0.83	0.66	0.49	59
52.5	1.60	1.40	1.20	1.00	0.80	0.60	50
45.0	1.93	1.68	1.44	1.20	0.96	0.72	42
37.5	2.38	2.08	1.78	1.49	1.19	0.89	34
30.0	3.06	2.68	2.30	1.91	1.53	1.15	26
22.5	4.21	3.68	3.16	2.63	2.10	1.58	19
15.0	6.51	5.70	4.88	4.07	3.26	2.44	12
7.5	13.5	11.77	10.09	8.41	6.73	5.04	6

Junction to ambient thermal resistance, R _{th j-a}	< 20.0	K/W
Junction to case thermal resistance, R _{th j-c}	< 0.35	K/W
Case to heatsink thermal resistance, R _{th c-s}	< 0.10	K/W
Maximum allowable case temperature	100 (212)	C (F)
Maximum allowable junction temperature	125 (257)	C (F)