



Gas and Flame Detection

# Operation and Maintenance Manual

---

GASMAX II Single / Dual Channel Gas Monitor

---

GDS Corp.  
2513 Hwy 646 • Santa Fe, Texas 77510  
409-927-2980 • 409-927-4180 (Fax) • [www.gdscorp.com](http://www.gdscorp.com)

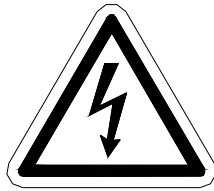

**CAUTION: FOR SAFETY REASONS THIS EQUIPMENT MUST BE OPERATED AND SERVICED BY QUALIFIED PERSONNEL ONLY. READ AND UNDERSTAND INSTRUCTION MANUAL COMPLETELY BEFORE OPERATING OR SERVICING.**

**ATTENTION: POUR DES RAISONS DE SÉCURITÉ, CET ÉQUIPEMENT DOIT ÊTRE UTILISÉ, ENTRETENU ET RÉPARÉ UNIQUEMENT PAR UN PERSONNEL QUALIFIÉ. ÉTUDIER LE MANUE D'INSTRUCTIONS EN ENTIER AVANT D'UTILISER, D'ENTRETENIR OU DE RÉPARER L'ÉQUIPEMENT.**

REVISION HISTORY

Revision 3.5.1 4/15/13 Initial rewrite for GASMAX II

Revision 3.5.2 11/1/13 Updated sensor specifications reference

Revision 3.5.3 5/4/14 Updated for new local GDS-IR interface

## CONTENTS

<b>1</b>	<b>SAFETY INFORMATION</b>	<b>10</b>
<b>2</b>	<b>GENERAL INFORMATION</b>	<b>11</b>
	Introduction	11
	Display Screens	12
	GASMAX Sensors	14
<b>3</b>	<b>SPECIFICATIONS</b>	<b>15</b>
<b>4</b>	<b>INSTALLATION</b>	<b>16</b>
	Selecting a Location	16
	Mounting the GASMAX II Instrument Enclosure	16
	Mounting a Remote Sensor	16
	Explosion Proof Installation	17
	Intrinsically Safe Installation	17
	Connecting DC Power & Output Signal Wiring	18
	Optional Relay + MODBUS Interface	19
	Relay Functionality	19
	MODBUS Wiring	20
	Optional Dual Channel MODBUS Interface Board	22
	Optional Dual Isolated 4-20mA Output Board	22
	Local Toxic Sensor	23
	Connecting a Remote Toxic Sensor	24
	Local Combustible Sensor	25
	Connecting a Remote Combustible Sensor (Ch 2)	26
	Remote Bridge Sensor Initial Setup	26

Initial Bridge Sensor “Volts” Check _____	27
Initial Bridge Sensor “Balance” Check _____	27
Local GDS-IR Infrared Sensor (Ch 2) _____	28
Connecting a Remote GDS-IR Infrared Sensor (Ch 2) _____	29
Connecting an External 4-20mA Input Device (Ch 2) _____	30
GASMAX Dual 4-20mA or 4-20MA + Bridge Input Option _____	31
Initial Setup _____	34
<b>5 CALIBRATION _____</b>	<b>35</b>
Calibration Overview _____	35
Calibration Procedure _____	36
<b>6 OPERATION and MAINTENANCE _____</b>	<b>38</b>
Normal Operating Mode _____	38
Alarm Operation – ALARM 1 and 2 _____	38
Alarm Operation – ALARM 3 _____	38
Sensor Replacement – Local Sensors _____	38
Sensor Replacement – Remote Sensors _____	40
Normal Maintenance _____	40
<b>7 USER MENUS _____</b>	<b>41</b>
Main Menu _____	41
System Configuration Page _____	42
Measurement Name _____	42
Eunits _____	42
Zero (0%) _____	42
Span (100%) _____	42
Decimal Points _____	42
Cal Span Value _____	42
Readout Deadband _____	42

Track Negative _____	42
Temp Compensation _____	43
Backup Config _____	43
Restore Config _____	43
Upload Sensor Data _____	43
Cal Marker _____	43
TX Sensor Life _____	43
<b>Alarm Settings Page _____</b>	<b>44</b>
Set Point _____	44
Dead-Band _____	44
ON Delay _____	45
OFF Delay _____	45
Low Trip _____	45
Latching _____	45
Display Event Log _____	45
Clear Event Log _____	45
RS-485 Communications _____	45
<b>Sensor Setup _____</b>	<b>45</b>
Install New Sensor _____	46
Recall Cal History _____	46
Input Type _____	46
New Sensor _____	46
Recent Cal _____	46
<b>Clock / Delay Setup Page _____</b>	<b>46</b>
Time _____	47
Date _____	47
Warm Up Delay _____	47
Cal Purge Delay _____	47
<b>LCD Contrast Adjustment Page _____</b>	<b>47</b>
<b>HELP Screen Page _____</b>	<b>47</b>
<b>Diagnostics Page _____</b>	<b>47</b>
Output Simulation _____	47
Relay Test _____	48

<b>System Security Page</b>	<b>48</b>
Contact Name	48
Secure Level	48
<b>8 TECHNICIANS MENUS</b>	<b>49</b>
<b>XMITTER CONFIG Menu</b>	<b>49</b>
O2 / Toxic	49
LEL / Current	49
Output Zero / Span Trim	49
Real Time Clock	49
Model	49
<b>TECHNICAL PAGE Menu</b>	<b>50</b>
Set Balance	50
Set Voltage	50
Set Gain to Unity	51
Preamp Gain Set	51
Zero Cal Value	52
Raw Min / Max Counts	52
Marker Active	52
Marker TX LED	53
Mark Level	53
Mark As Message	53
<b>9 MODBUS REGISTERS</b>	<b>54</b>
List of GASMAX II MODBUS variables	54
Channel Status Word Bit Definition	56
Alarm Status Word Bit Definition	57
Transmitter Status Word Bit Definition	57
Channel Floating Point Definition	57
<b>10 TROUBLESHOOTING GUIDELINES</b>	<b>58</b>
Toxic Sensor Indicates Fault or Overrange	58
Toxic Sensor Will Not Calibrate	58

Bridge Sensor Indicates Fault or Overrange _____	58
Bridge Sensor Will Not Calibrate _____	58
Receiving Device and GASMAX Displayed Values Don't Match _____	58
Controller MODBUS Data Incorrect _____	59
Controller Showing MODBUS COMM ERROR _____	59
GASMAX Display Blank _____	59
GASMAX Error Codes _____	59
Software reset ("Cold Boot") _____	60
<b>11 SPARE PARTS _____</b>	<b>61</b>
Display and Enclosure _____	61
Expansion Boards _____	62
Sensor Head Accessories _____	62
Remote Direct Sensor _____	63
Remote Sensor Transmitter _____	63
Dual Local Sensors _____	64
<b>12 Drawings and Dimensions _____</b>	<b>65</b>

**TABLE OF FIGURES**

FIGURE 2-1: GASMAX II DATA, DUAL CHANNEL AND TREND DISPLAY..... 11

FIGURE 2-2: GASMAX DATA DISPLAY..... 12

FIGURE 2-3: GASMAX TREND DISPLAY..... 13

FIGURE 2-4: GASMAX DUAL CHANNEL DISPLAY..... 13

FIGURE 2-5: GASMAX DISPLAY SEQUENCE - SINGLE CHANNEL..... 13

FIGURE 2-6: GASMAX DISPLAY SEQUENCE - DUAL CHANNEL..... 14

FIGURE 4-1: GASMAX II REMOTE SENSOR..... 17

FIGURE 4-2: GASMAX II POWER & SIGNAL WIRING..... 18

FIGURE 4-3: OPTIONAL RELAY / MODBUS INTERFACE BOARD..... 19

FIGURE 4-4: MODBUS WIRING (TYPICAL)..... 20

FIGURE 4-5: MODBUS WIRING (MODBUS JUNCTION BOX)..... 21

FIGURE 4-6: MODBUS JBOX LOCATION OPTIONS..... 22

FIGURE 4-7: OPTIONAL DUAL ISOLATED 4-20MA OUTPUT..... 22

FIGURE 4-8: LOCAL SMART TOXIC SENSOR CONNECTION..... 23

FIGURE 4-9: REMOTE TOXIC SENSOR CONNECTION..... 24

FIGURE 4-10: LOCAL SMART BRIDGE SENSOR CONNECTION..... 25

FIGURE 4-11: REMOTE BRIDGE SENSOR CONNECTION..... 26

FIGURE 4-12: GASMAX WITH LOCAL GDS-IR..... 28

FIGURE 4-13: REMOTE GDS-IR CONNECTION..... 29

FIGURE 4-14: REMOTE 4-20MA INPUT (CH 2)..... 30

FIGURE 4-15: DUAL 4-20MA INPUT OPTION..... 31

FIGURE 4-16: DUAL 4-20MA INPUT..... 32

FIGURE 4-17: 4-20MA / BRIDGE INPUT..... 33

FIGURE 5-1: CALIBRATION FLOWCHART..... 37

FIGURE 6-1: GASMAX SENSOR REPLACEMENT..... 39

FIGURE 6-2: SMART SENSOR RECOGNITION SCREEN..... 40

FIGURE 7-1: MAIN MENU FLOWCHART..... 41

FIGURE 7-2: SYSTEM CONFIG MENU..... 42

FIGURE 7-3: SENSOR LIFE TRANSMISSION FORMAT..... 44

FIGURE 7-4: ALARM SETTINGS MENU..... 44

FIGURE 7-5: RS-485 MODBUS MENU..... 45

FIGURE 7-6: SENSOR SETTINGS MENU..... 46

FIGURE 7-7: CLOCK DELAY MENU..... 46



FIGURE 7-8: CONTRAST MENU.....	47
FIGURE 7-9: DIAGNOSTICS MENU .....	47
FIGURE 7-10: SYSTEM SECURITY MENU.....	48
FIGURE 8-1: XMITTER CONFIG MENU.....	49
FIGURE 8-2: TECHNICAL PAGE MENU.....	50
FIGURE 8-3: SENSOR BALANCE & VOLTAGE SET MENU.....	51
FIGURE 8-4: SET GAIN TO UNITY MENU.....	51
FIGURE 8-5: PREAMP GAIN SET MENU .....	52
FIGURE 11-1: GASMAX II + LOCAL SENSOR SPARE PARTS.....	61
FIGURE 11-2: GASMAX SENSOR HEAD.....	61
FIGURE 11-3: GASMAX EXPANSION BOARDS.....	62
FIGURE 11-4: GASMAX SENSOR HEAD SPLASH GUARD & FLOW CELL.....	62
FIGURE 11-5: GASMAX II REMOTE DIRECT SENSOR HEAD.....	63
FIGURE 11-6: GASMAX II REMOTE SENSOR TRANSMITTER.....	63
FIGURE 11-7: GASMAX II DUAL WITH Y-ADAPTER.....	64
FIGURE 12-1: GASMAX LOCAL SENSOR DIMENSIONS.....	65
FIGURE 12-2: GASMAX DUAL LOCAL SENSOR DIMENSIONS .....	65

## 1 SAFETY INFORMATION

### Important – Read Before Installation

Users should have a detailed understanding of GASMAX II operating and maintenance instructions. Use the GASMAX II only as specified in this manual or detection of gases and the resulting protection provided may be impaired. Read the following WARNINGS prior to use.

#### WARNINGS

- The GASMAX II gas monitor described in this manual must be installed, operated and maintained in accordance with information contained herein. Installation in any hazardous area must comply with all applicable restrictions, requirements and guidelines for said hazardous areas. It is the end user customer's final decision to ensure that the GASMAX II is suitable for the intended use.
- The GASMAX II is designed and constructed to measure the level of certain gases in ambient air. Accuracy in atmospheres containing steam or inert gases cannot be guaranteed.
- Always mount the sensor head vertically with the sensor head facing down. However, the GDS-IR infrared sensor may be mounted vertically or horizontally.
- Do not paint transmitter or sensor assembly.
- Do not operate the GASMAX II if its enclosure is damaged or cracked or has missing components. Make sure the cover, internal PCB's and field wiring are securely in place before applying power.
- Do not expose the GASMAX II to electrical shock or continuous severe mechanical shock. Protect the GASMAX II and related sensor assemblies from dripping liquids and high power sprays.
- Calibrate with known target gas at start-up and check on a regular schedule, at least every 90 days. More frequent inspections are encouraged to spot problems such as dirt, oil, paint, grease or other foreign materials on the sensor head.
- Periodically test for correct operation of the system's alarm events by exposing the monitor to a targeted gas concentration above the High Alarm set point.
- Use only for applications described within this manual.

## 2 GENERAL INFORMATION

### INTRODUCTION

The GASMAX II is a single or dual channel fixed-point gas monitor designed to provide continuous monitoring of toxic or combustible gases in hazardous areas. Gas values are displayed in calibrated engineering units as well as bar graph or 30-minute trend graph format.

The GASMAX II supports one or two local or remote mount sensors for toxic or combustible gases. The advanced microcontroller, non-intrusive magnetic interface and superior graphic LCD interface offers rapid setup, simplified operation and enhanced diagnostics not found in previous generation products. On-board non-volatile memory retains all configuration data during power interruptions. Two independent 4-20 mA outputs allow for easy connection to control systems or other alarm instrumentation. Additional output options include alarm relays and single or dual channel MODBUS slave interfaces.

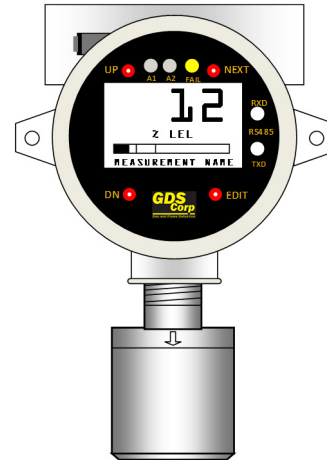

Built-in user-prompted calibration makes it easy for one person to perform calibration and maintenance without opening the enclosure or declassifying the area. A battery-powered real-time clock and event log allows the GASMAX II to track calibration and alarm events for later recall on the LCD readout.

The GASMAX II display is shown in Figure 2-1. There are four magnetic switches on the face of the GASMAX II, arranged in a quadrant around the LCD display. Starting in the upper right and proceeding clockwise these are labeled NEXT, EDIT, DOWN/CAL and UP. To activate, or “press” a magnetic switch, swipe the magnet near the switch.



Figure 2-1: GASMAX II DATA, DUAL CHANNEL and TREND DISPLAY

Pressing the NEXT key causes the GASMAX display to switch display screens. In single channel mode, the display will switch between DATA and TREND. In dual channel mode, the sequence will be: DATA 1, DATA 2, TREND 1, TREND 2, DUAL CHANNEL, followed by DATA 1.

The EDIT key activates the USER MENU display mode. When in user menu display mode, use UP and DOWN to select an item, EDIT to change an item, and NEXT to exit the menu or function and return the GASMAX II to display mode.

Activating DOWN/CAL, followed by EDIT, while in display mode initiates calibration mode. For the balance of this manual, the term “press” will be used to describe activation of any key via the magnetic wand.

## DISPLAY SCREENS

The DATA display screen shows a single channel’s information. The current value is shown in calibrated engineering units. A horizontal bargraph tracks the current value and shows the Alarm 1 and Alarm 2 values in graphical form. The user-programmable Engineering Units (“Eunits”) and Measurement Name text strings are shown below the real-time reading.

Above the LCD display, three LEDs indicate the status of the level and fault alarms. If relays are installed, the LEDs indicate whether the relays are active. Note that if any relay is set for FAILSAFE operation, if LED is ON the relay will be de-energized. In dual channel mode, if either channel is in alarm the corresponding A1 or A2 indicator LED (and relay) will be energized.

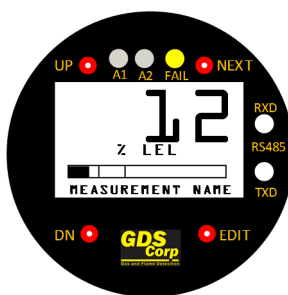

**Figure 2-2: GASMAX Data Display**

To the right of the LCD display, two LEDs monitor the MODBUS RS-485 transmit (TXD) and receive (RXD) buffers. Flashing indicates sent or received data. In normal operation, RXD will flash whenever a message from the MODBUS master is received and TXD will flash when any response message is transmitted from the GASMAX. These only operate if a MODBUS interface is installed.

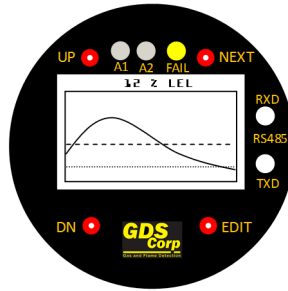

Figure 2-3: GASMAX Trend Display

The TREND display shows a graphical representation of the most recent 30 minute trend. The Alarm 1 level is shown as a closely spaced dotted line, and the Alarm 2 level is shown as a widely spaced dashed line.

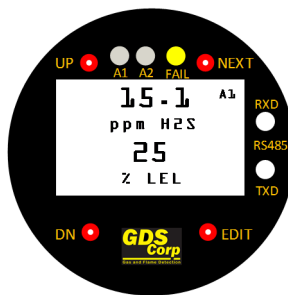

Figure 2-4: GASMAX Dual Channel Display

When operating in dual channel mode, an additional display option is available that shows both channels calibrated values and engineering units. Measurement name values are not shown. In addition, to the right of each value there are indicators for Alarm 1 (“A1”), Alarm 2 (“A2”) and Fault.

To switch between displays, use the NEXT key. In single channel mode, pressing the NEXT key will switch between the DATA screen and the TREND screen. In dual channel mode, pressing the NEXT key will sequence through five screen options as shown in Fig. 2-5.

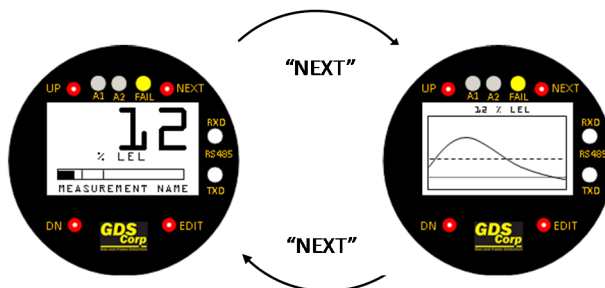

Figure 2-5: GASMAX Display Sequence - Single Channel

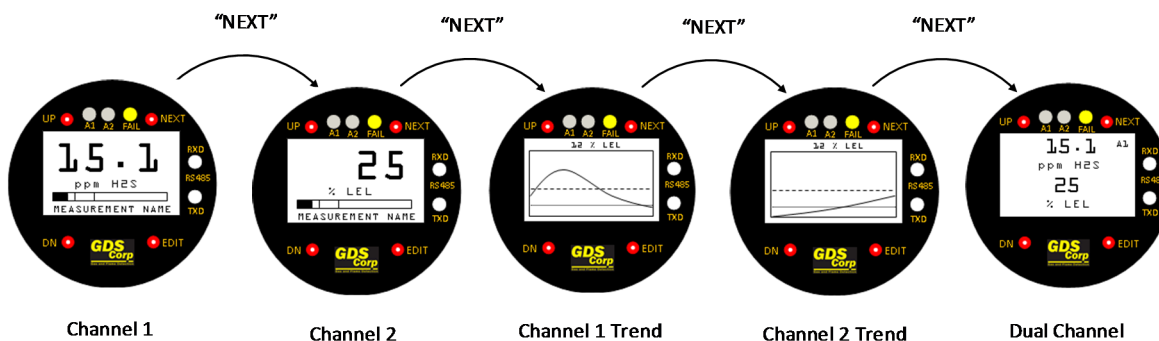

Figure 2-6: GASMAX Display Sequence - Dual Channel

### GASMAX SENSORS

For toxic gases the GASMAX II supports a wide range of electrochemical (“echem”) sensors. These sensors use chemical reactions to sense the presence of gases such as hydrogen sulfide, chlorine, sulfur dioxide and many others. Echem sensors output very low level signals; remote echem sensors should be mounted no more than 15 feet from the GASMAX enclosure, the wiring should be three-conductor with foil shield, and the wiring should be enclosed in metal conduit for maximum protection against interference. If longer distance is required, the GASMAX offers a sensor-transmitter option for electrochemical sensors that converts the output into a 4-20mA signal. Distances up to 500 feet are practical with 4-20mA signals. Channel 1 on the GASMAX II can be configured for direct echem or 4-20mA input.

**IMPORTANT: TOXIC SENSORS ARE SUBJECT TO ACCELERATED DETERIORATION IF POWER IS NOT SUPPLIED WITHIN 3 MONTHS OF SHIPMENT FROM GDS CORP.**

For combustible gases the GASMAX II offers three different choices. For lowest cost and widest range, a traditional catalytic bead (“cat bead”) sensor is available. In addition, the GASMAX II supports the GDS Corp SmartIR infrared sensor or GDS-IR infrared sensor. The GASMAX II also supports several photoionization detector (PID) sensors for measurement of volatile organic compounds such as benzene or toluene. Channel 2 on the GASMAX II can be configured for direct bridge or 4-20mA input.

### 3 SPECIFICATIONS

Model	GASMAX II Single / Dual Channel Gas Monitor
Power Input	10-30VDC at < 4 watts with relay board. Additional power required for Extended Temp & GDS-IR option.
Display	64 x128 pixel LCD with engineering units, bargraph and 30-minute trend
Channel One Input	Microamp-level input for local or remote GDS Corp toxic gas sensors Optional 4-20mA input for remote sensor transmitters, GDS-IR, GDS-50 or other 4-20mA source
Channel Two Input	Bridge-type input with adjustable excitation voltage for local or remote Catalytic Bead, SmartIR or PID sensor Optional 4-20mA input for remote sensor transmitters, GDS-IR, GDS-50 or other 4-20mA source
Accuracy	+/- 5% of full scale (typical)
Standard Output	Dual three-wire 4-20mA current source outputs with fault and overrange indication. Maximum loop resistance is 750 ohms with standard 24VDC supply
Optional Output	Relay / MODBUS interface with 3x 5A SPDT programmable alarm relays Dual isolated 4-20mA outputs Single or dual input MODBUS slave interface (no relays)
Temperature	Electronics -40°C to +60°C. See Sensor Manual for additional details
Memory	On-board non-volatile memory retains all user settings
Housing	Aluminum housing with epoxy paint standard; #316 stainless steel optional One ¾" NPT female connection for local sensor head Two ¾" NPT female connections for conduit or cable glands
Dimensions	Width 5.4" (137 mm), Height 8" (203 mm), Depth 5" (127 mm) Shipping weight 6.5 pounds (3 kg)
Approvals	CSA Certified Division 1 & 2 Groups B, C, D. Suitable for explosion-proof installations with flame arrestor ATEX Certified EX II 2 G EEx d IIB + H2 T5 (Note: ATEX Certification requires type 12-15 sensor heads)
Warranty	Two years on electronics, one year on sensor

## 4 INSTALLATION

### SELECTING A LOCATION

Factors such as prevailing winds, target gas density, potential leak sources, air movement machinery and similar environmental variables are important when selecting a location for the GASMAX II gas monitor or gas sensor. Even though the GASMAX II is designed for rugged service, sensors and electronics should be protected from environmental damage due to water, snow, shock, vibration and dirt. In addition, the sensor and / or display should be located such that regular maintenance and periodic sensor replacement can be readily accomplished. While there are no industry standards for gas detector placement, professional tools exist that can simulate leaks or spills and provide excellent guidance for locating gas detectors throughout a facility.

### MOUNTING THE GASMAX II INSTRUMENT ENCLOSURE

The GASMAX II standard enclosure is a cast aluminum explosion-proof (NEMA 7) enclosure as shown in Figure 4-1. Two channel GASMAX II units with dual local sensor heads include a “Y” adapter, shown in Figure 4-2.

The GASMAX II or remote sensor should always be mounted with the sensor head opening facing down. If necessary, a Splash Guard (p/n 10-0205) should be attached if there is any chance that water or liquid spray could enter the sensor opening from below. Be sure to leave sufficient room (~ 12”) below the sensor head to allow easy access for attachment of a Calibration Cup and / or removal of the sensor head cover for sensor replacement.

### MOUNTING A REMOTE SENSOR

GASMAX II remote sensors consist of a cast aluminum explosion-proof junction box and stainless steel sensor head (see Fig. 4-3). The junction box contains a PCB with an interface for the sensor head cable and wiring terminals for the three-wire connection to the GASMAX monitor. Fittings are 3/4” NPT. The sensor head should ALWAYS be mounted vertically as shown, and GDS Corp recommends side entry for all conduit runs. GASMAX monitors support up to two remote sensors.



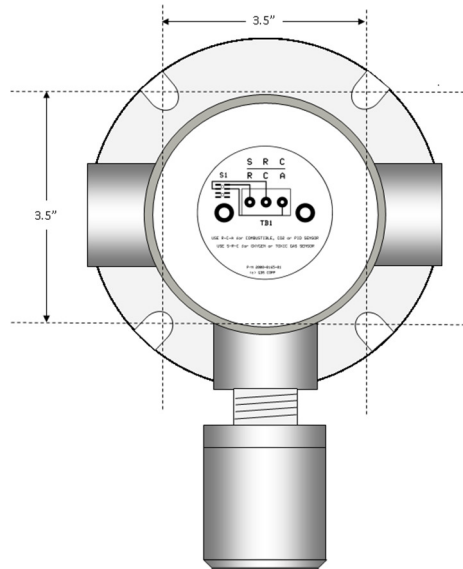

**Figure 4-1: GASMAX II Remote Sensor**

#### **EXPLOSION PROOF INSTALLATION**

GASMAX II monitors with standard explosion-proof sensor heads are certified for use in Class 1 Division 1 hazardous areas. Installation in these areas should follow best industry standard practices and all appropriate electrical codes. Generally, these codes require rigid metal conduit, poured seals and other installation elements necessary to ensure safety. In all cases, GDS Corp recommends any GASMAX sensor be mounted vertically with the sensor opening facing down. If there is a possibility that water or other liquid may be present, GDS Corp further recommends the installation of a sensor head Splash Guard (p/n 10-0205) to protect the sensor from damage. For maximum protection against RF interference or electrical surge, the GASMAX II enclosure, all remote sensors and interconnecting conduit must be properly grounded.

#### **INTRINSICALLY SAFE INSTALLATION**

The GASMAX II is not certified for use as an Intrinsically Safe device.

### CONNECTING DC POWER & OUTPUT SIGNAL WIRING

To access the GASMAX signal and power connections, remove the cover on the GASMAX II explosion-proof enclosure, loosen the 2 thumbscrews holding the display assembly and remove it. The display will remain connected to the IO/Power Supply PCB mounted in the back of the enclosure by a short ribbon cable. Route the power and signal wires through the conduit entry and connect to terminal block “TB2” (see Fig. 4-4).

Plus 24VDC connects to TB2-1. DC Ground connects to TB2-4. Channel One 4-20mA output is available on TB2-2 and Channel Two 4-20mA output is available on TB2-3. **GDS Corp always recommends using shielded wire for signal and power cable.**

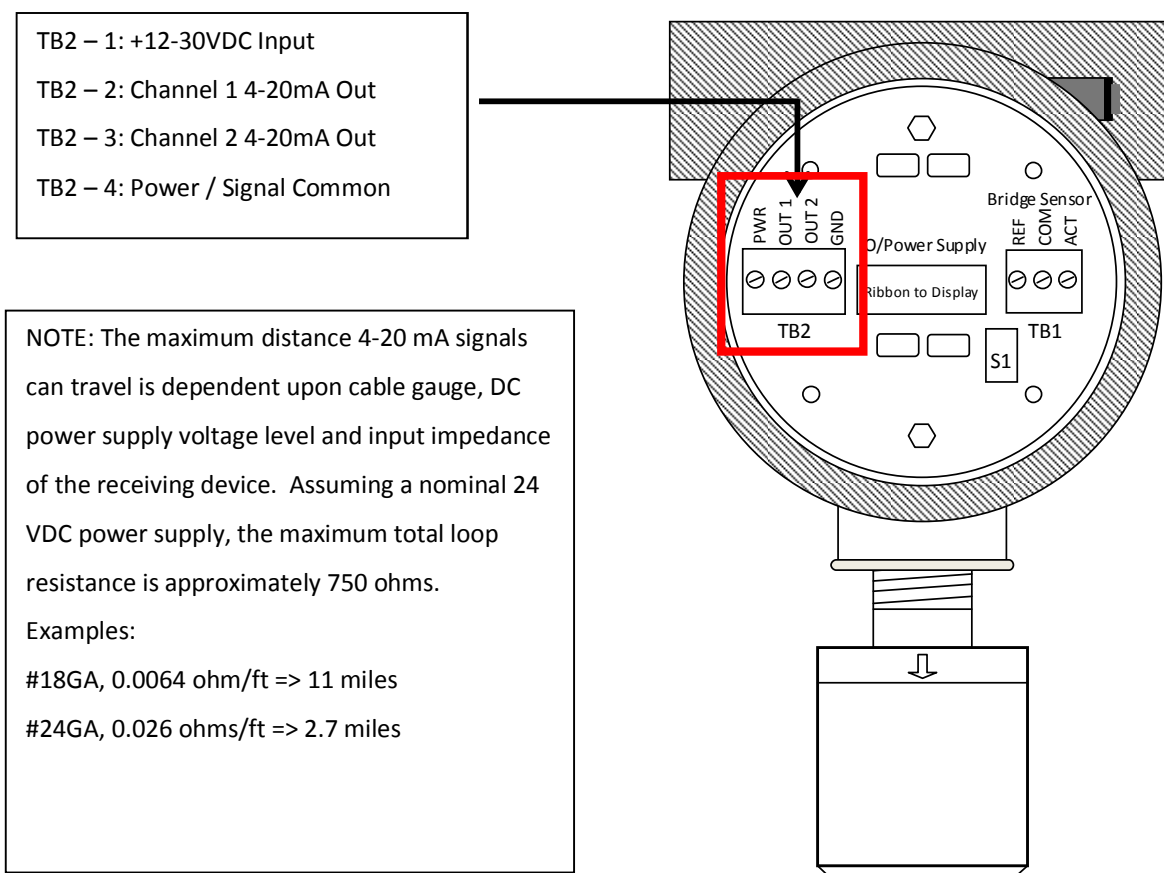

Figure 4-2: GASMAX II Power & Signal Wiring

## OPTIONAL RELAY + MODBUS INTERFACE

The optional 10-0234 Relay / Modbus board is connected “piggyback” to the back of the GASMAX II Display Assembly and supplies two level alarm relays (“K1” and “K2”), a FAULT relay (“K3”) and an RS-485 Modbus RTU slave port. If dual isolated 4-20mA outputs are *not* installed, GASMAX II units may be field upgraded with this option at any time.

## RELAY FUNCTIONALITY

Alarm relays are dry contact SPDT and may be configured as normal or failsafe (“normally open held closed”). Power must be supplied from an external source and should be fused.

**WARNING: CONTACTS ARE RATED FOR RESISTIVE LOADS ONLY! INDUCTIVE LOADS, SUCH AS COILS, MOTORS OR SOLENOID VALVES MAY CAUSE ARCING WHICH SHORTENS LIFE AND MAY INTERFERE WITH SENSOR DATA.**

Relay K1 activates if either Channel 1 or Channel 2 exceed the programmed alarm 1 threshold and cannot be acknowledged. Relay K2 activates if either Channel 1 or Channel 2 exceed the programmed alarm 2 threshold and can be acknowledged (reset) from the front panel or via TB3. Relay K3 indicates sensor failure and is always failsafe (normally open held closed).

Remote Alarm Reset (TB3) can be used to acknowledge an Alarm 2 relay contact closure. Wiring from any remote pushbutton to TB3 should be shielded and protected from noise spikes to prevent false Alarm Reset commands.

A version of this board is available with MODBUS RTU slave only configuration (No relays).

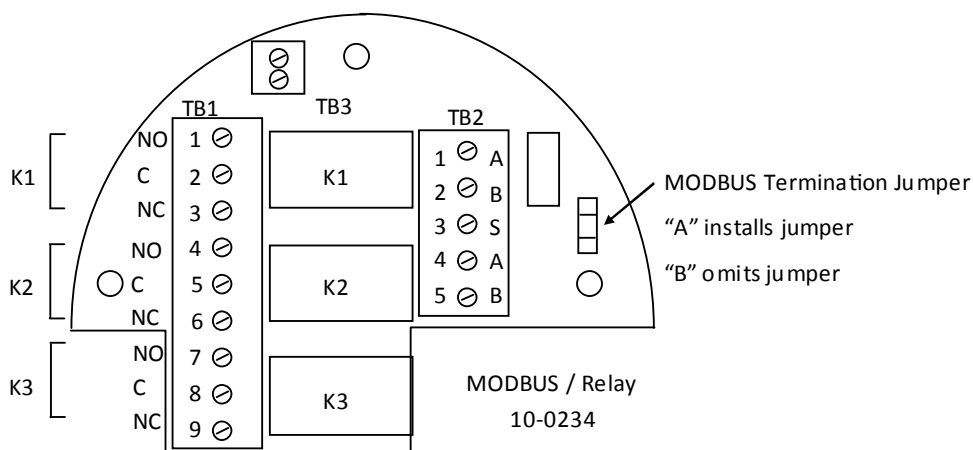
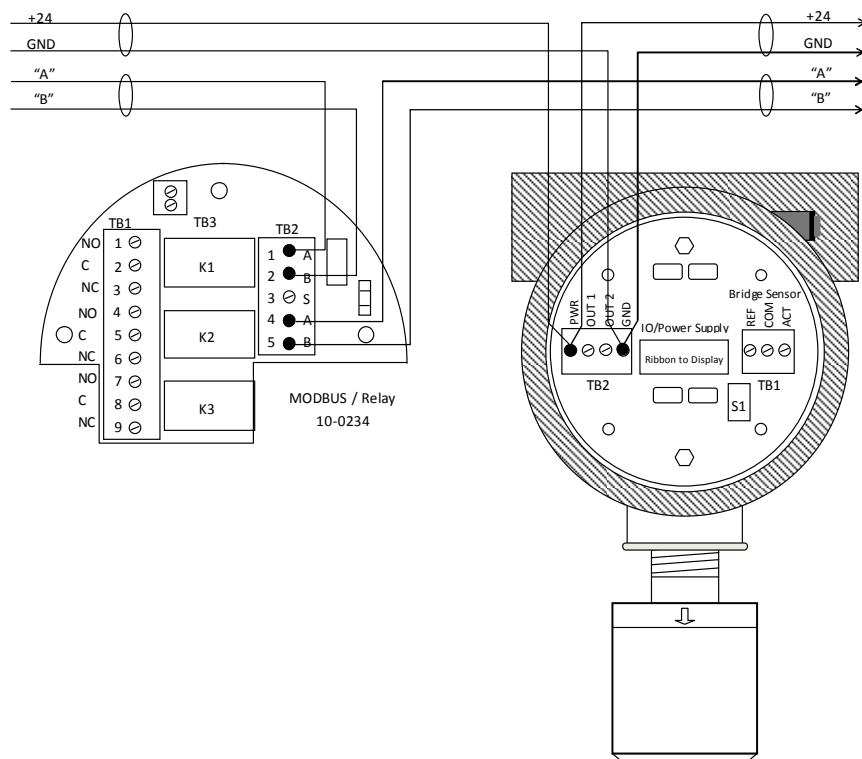

Figure 4-3: Optional Relay / MODBUS Interface Board

## MODBUS WIRING

Typical MODBUS wiring is shown in Figure 4-6. MODBUS system architecture requires that the devices in any MODBUS loop be connected in a daisy-chain layout. This minimizes signal reflections and improves signal noise margin. A MODBUS Termination Jumper installs a load resistor across the MODBUS signal lines and should only be set to “A” (ON) **at the last device in the string.**

Cable selection for MODBUS systems is important for both signal integrity and power distribution. MODBUS / RS-485 transmissions use low-voltage differential signaling to achieve reasonable data rates over very long distances, up to 4000 feet without a repeater. For MODBUS data signals, GDS Corp recommends 24GA shielded cable for best results. Power distribution, however may require larger gauge wire since it is critical that the supply voltage for the GASMAX at the far end of the string not fall below 12VDC during power-up and normal operation. If the GASMAX includes a GDS-IR infrared sensor, the voltage must not be allowed to drop below 18V on power-up.

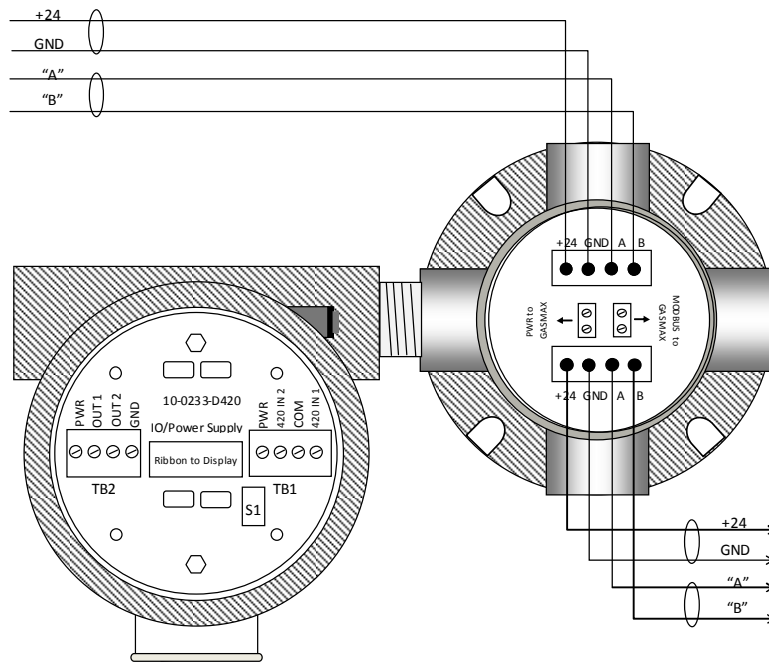

**Figure 4-4: MODBUS Wiring (Typical)**

Note that while the GASMAX has two sets of wiring terminals for MODBUS “A” and “B” signals, daisy-chain power wiring requires that two wires be installed in the “+24” and “GND” terminals on the GASMAX I/O Power Supply board. This can be difficult if wire sizes are larger than #18ga. Further, the addition of

multiple MODBUS and power wires inside the GASMAX enclosure can create problems and possibly damage components if the display has to be forced into place. Finally, if it is desired to disconnect the GASMAX from the MODBUS loop for troubleshooting, disconnecting the power wire removes power from all devices further down the loop and leaves a live male pin with +24V inside the enclosure.

For these reasons, GDS Corp recommends the addition of the MODBUS Wiring Junction Box (see Fig. 4-7). This option minimizes the need to access wiring inside the GASMAX II, provides individual wire landing points for incoming and outgoing MODBUS and power wiring and shields, and makes it easy to temporarily disconnect the GASMAX II power or MODBUS connections without affecting any other MODBUS devices.



**Figure 4-5: MODBUS Wiring (MODBUS Junction Box)**

The MODBUS wiring junction box is attached to the GASMAX, either on the bottom fitting or one of the side fittings, depending on installation requirements. Specify BOTTOM, LSIDE or RSIDE when ordering (See Fig. 4-8).

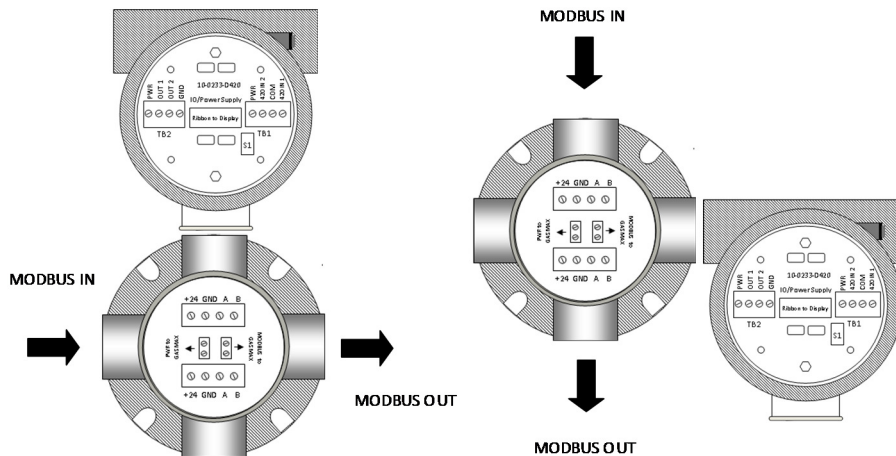

Figure 4-6: MODBUS JBOX LOCATION OPTIONS

**OPTIONAL DUAL CHANNEL MODBUS INTERFACE BOARD**

Product information on this option will be available in a future release of this manual.

**OPTIONAL DUAL ISOLATED 4-20mA OUTPUT BOARD**

The optional 10-0250 Dual Isolated 4-20mA output board provides two dual 4-20mA outputs that are electrically isolated from sensor inputs and the 24 VDC power source. Each 4-20mA output shares the same common ground and are therefore not isolated from each other. This board is connected “piggyback” to the back of the GASMAX II Display Assembly. GASMAX II units may be field upgraded with this option at any time.

**NOTE: ISOLATED 4-20mA AND MODBUS / RELAY BOARDS SHARE THE SAME CONNECTOR AND THEREFORE CANNOT BE INSTALLED SIMULTANEOUSLY.**

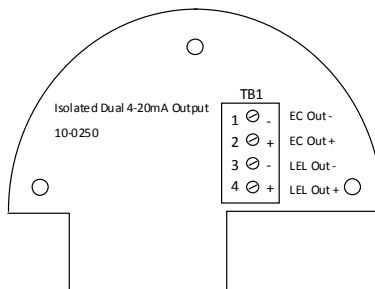
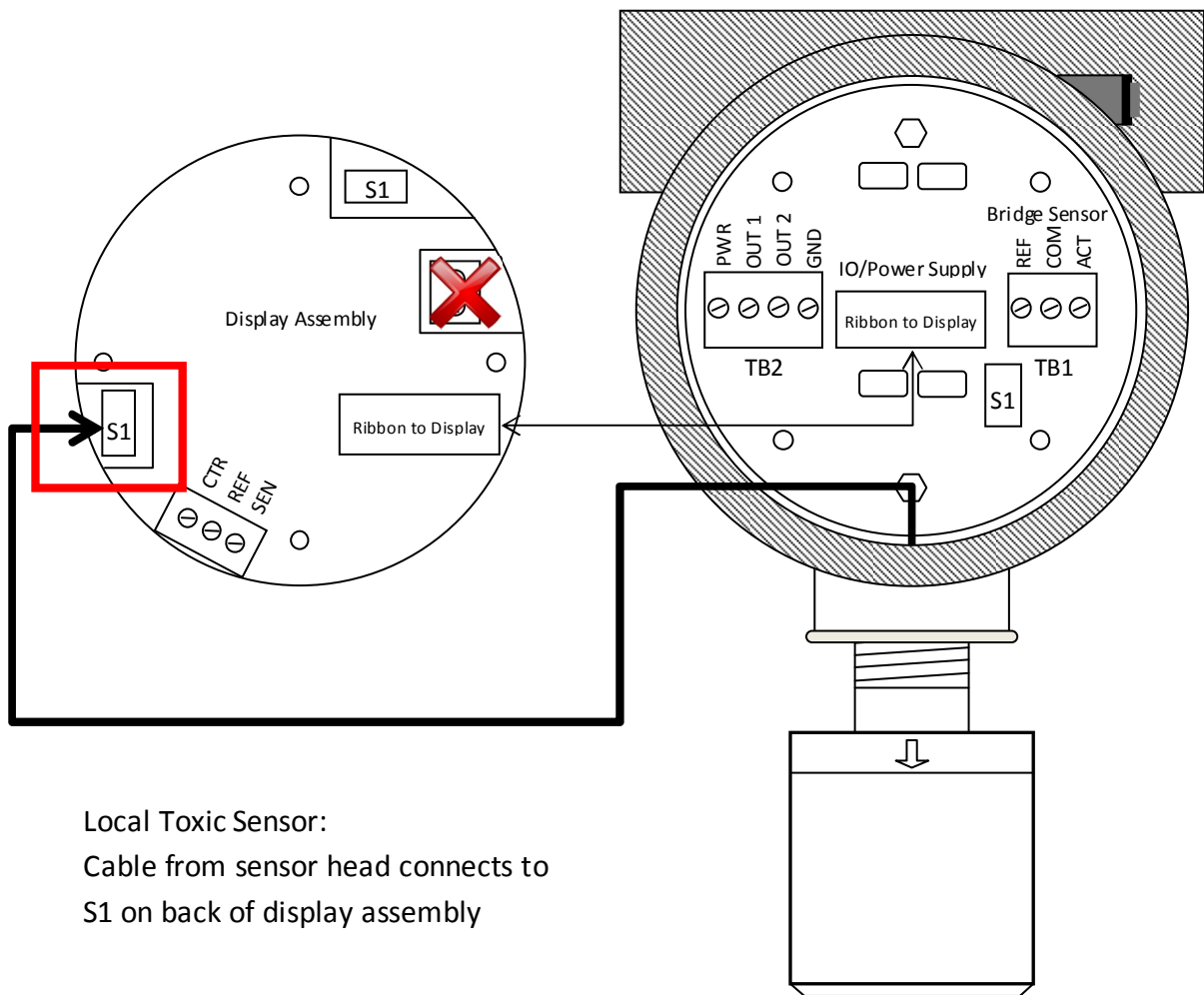

Figure 4-7: Optional Dual Isolated 4-20mA Output

## LOCAL TOXIC SENSOR

Local toxic sensors are factory installed in a sensor head directly attached to the GASMAX II enclosure. Local toxic sensors are always connected to the Channel 1 Smart Sensor connector "S1" located on the **back of the Display Assembly** (See Fig.4-5).

**IMPORTANT: TOXIC SENSORS ARE SUBJECT TO ACCELERATED DETERIORATION IF POWER IS NOT SUPPLIED WITHIN 3 MONTHS OF SHIPMENT FROM GDS CORP.**



Local Toxic Sensor:  
Cable from sensor head connects to  
S1 on back of display assembly

**Figure 4-8: Local Smart Toxic Sensor Connection**

### CONNECTING A REMOTE TOXIC SENSOR

GASMAX II monitors with remote-mount toxic sensors are shipped in two pieces and sensor wiring must be installed by the end user. Remote toxic sensors connect to the Channel 1 Simple Sensor input on the **back of the Display Assembly** as shown in Figure 4-6.

Due to the small signal output from toxic sensors, remote direct input toxic sensors should be mounted **no more than 15 wire-feet** from the GASMAX II display. Further, the cable used should be **three-wire stranded with foil shield** and should be **run inside metallic rigid conduit**. GDS Corp recommends Belden B8771. The cable shield must be connected to an earth ground at **ONE END ONLY**.

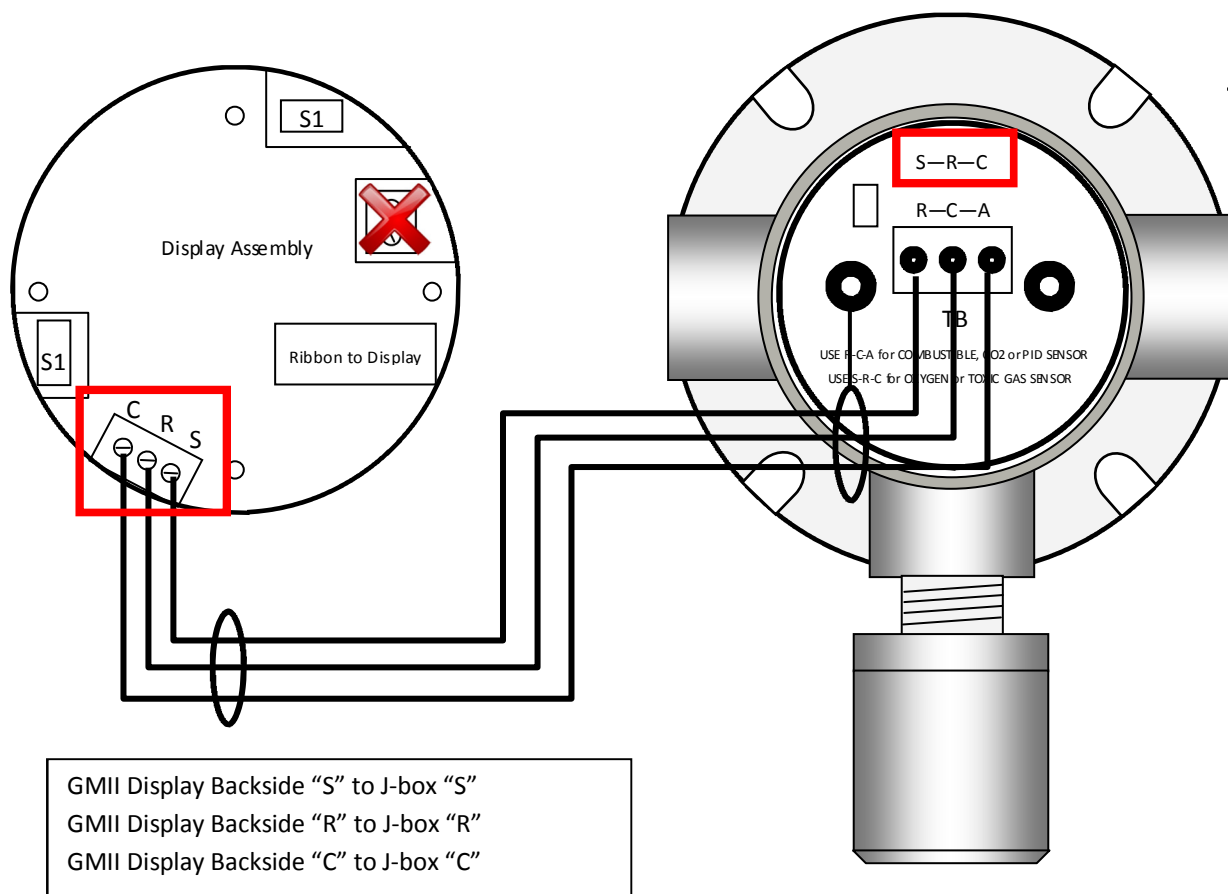

Figure 4-9: Remote Toxic Sensor Connection



### LOCAL COMBUSTIBLE SENSOR

Local bridge-type sensors, including catalytic bead or infrared sensors for combustibles and photoionization detectors (PID) for volatile organic compounds are factory installed and always connected to the Channel 2 Smart Sensor connector "S1" on the IO/Power Supply board, located on the back of the explosion proof enclosure (See Fig. 4-7).

**NOTE: LOCAL SMART BRIDGE SENSORS AUTOMATICALLY ADJUST SENSOR EXCITATION VOLTAGE.**

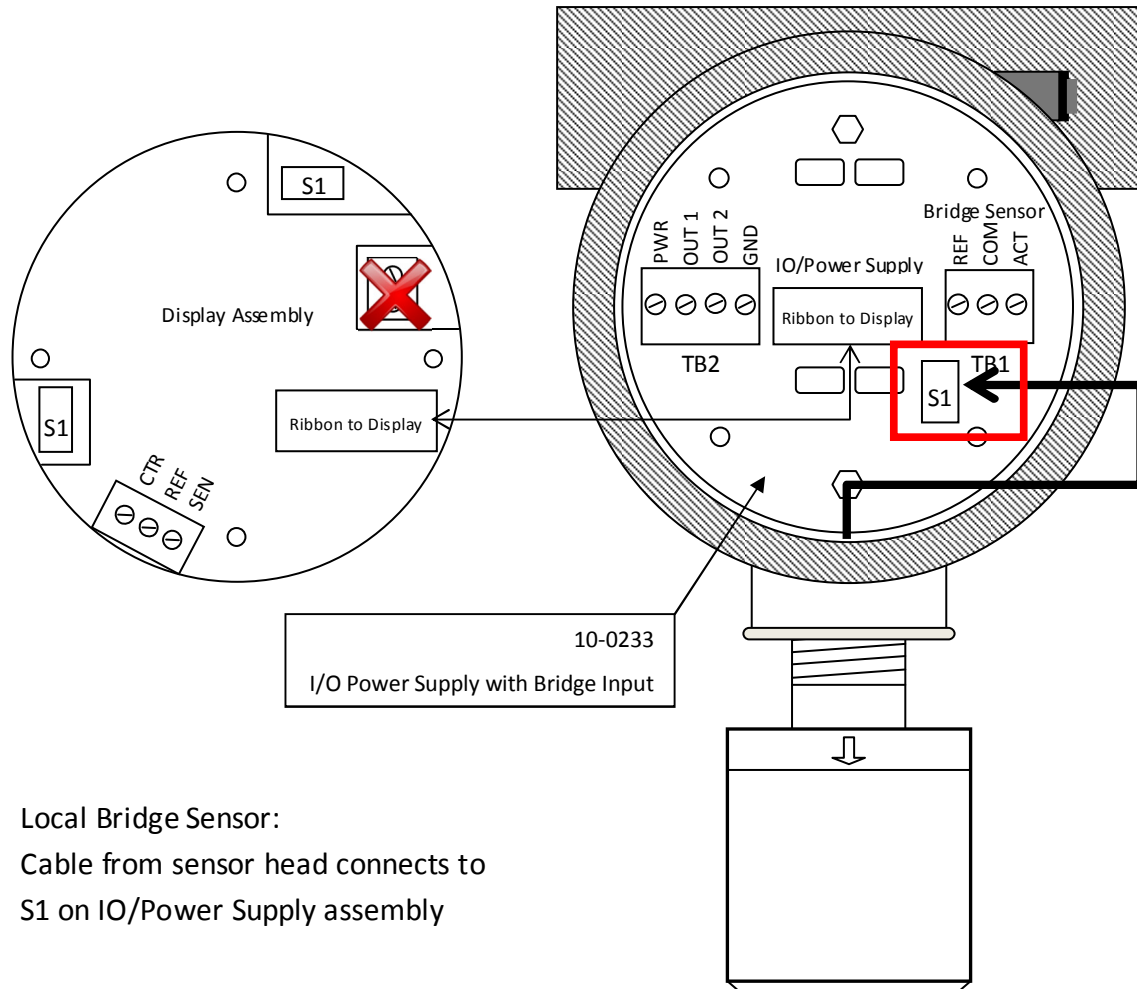

**Figure 4-10: Local Smart Bridge Sensor Connection**

## CONNECTING A REMOTE COMBUSTIBLE SENSOR (CH 2)

GASMAX II monitors with remote-mount bridge-type sensors are shipped in two pieces and sensor wiring must be installed by the end user. Bridge-type sensors have a more robust output and can be mounted up to 100 feet from the GASMAX II. Cable used should be **three-wire stranded with foil shield** and should be **run inside metallic rigid conduit where possible**. GDS Corp recommends Belden B8771. The cable shield must be connected to an earth ground at ONE END ONLY. Remote bridge sensors connect to “TB1” on the **IO/Power Supply board, located on the back of the explosion proof enclosure** (See Fig 4-8).

**WARNING: REMOTE BRIDGE SENSORS DO NOT AUTOMATICALLY ADJUST SENSOR EXCITATION VOLTAGE. IF SWITCHING SENSOR TYPES, BE SURE TO ADJUST SENSOR VOLTAGE BEFORE INSTALLING A NEW SENSOR.**

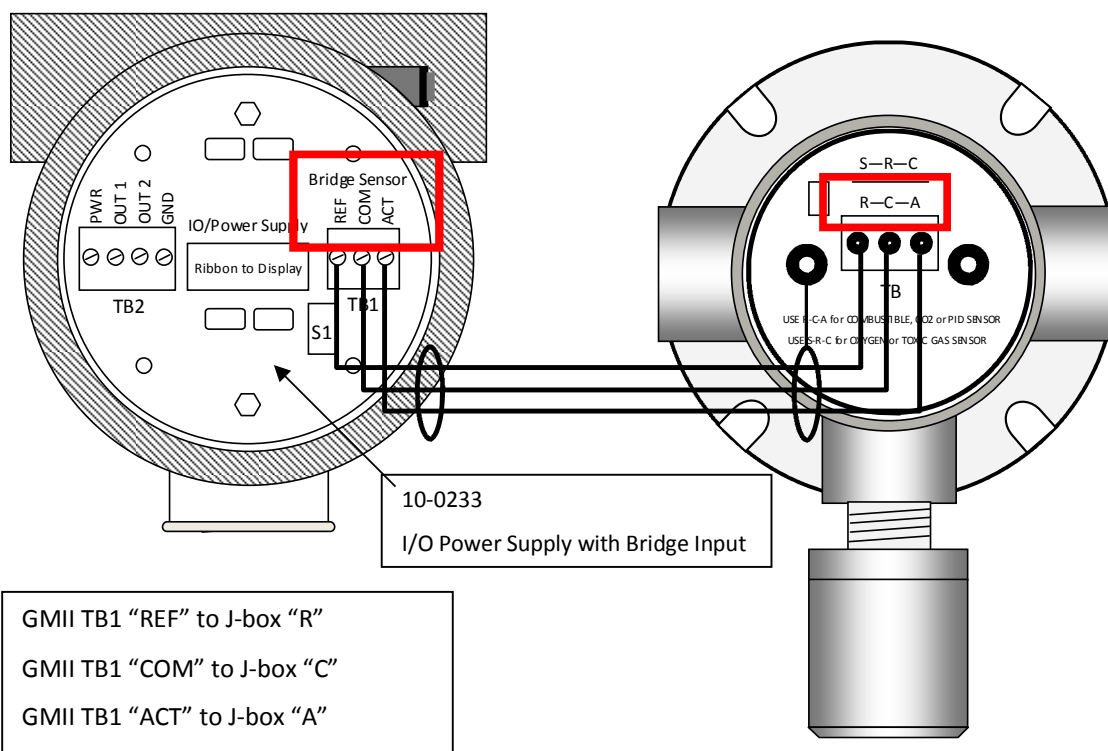

Figure 4-11: Remote Bridge Sensor Connection

### REMOTE BRIDGE SENSOR INITIAL SETUP

GASMAX gas monitors with remote bridge sensors require one-time adjustments to Voltage and Balance to ensure proper operation. These adjustments compensate for the unknown length of cable between the GASMAX and remote sensor head and any changes to the sensor’s characteristics as a result of shipping and installation.

### INITIAL BRIDGE SENSOR “VOLTS” CHECK

Bridge sensors require specific excitation voltages to operate properly. This voltage must be measured at the Remote Sensor Head Junction Box, between points “R(+)” and “A(-)” (See Fig. 4-11). When shipped

from the factory, the GASMAX excitation voltage will be preset for the type of bridge sensor specified (see Sensor Type table).

However, this voltage *may* need to be adjusted to compensate for voltage drop in the sensor cable.

Sensor Type	Voltage	Current	Warmup
Catalytic Bead (“7x”)	2.0 ± 5%	300 mA	3 hrs
SmartIR (Type “5x”)	4.5 ± 10%	85 mA	1 hr
PID (Type “6x”)	3.3 ± 5%	35 mA	12 hrs

**NOTE:** IF YOU ARE NOT CERTAIN THAT SENSOR VOLTAGE IS ADJUSTED PROPERLY, DISCONNECT THE REMOTE SENSOR **BEFORE** APPLYING POWER TO THE GASMAX MONITOR. ADJUST SENSOR EXCITATION VOLTAGE AS SHOWN IN THE TABLE ABOVE AND *THEN* CONNECT THE REMOTE SENSOR.

To adjust sensor excitation voltage, access the Technicians Menu (see Section 8.2). Select Set Voltage and use the UP and DOWN keys to set the voltage. Keep in mind that the voltage at the GASMAX “R” and “A” pins may need to be higher to compensate for voltage drop in the cable.

**WARNING:** EXCEEDING A SENSOR’S EXCITATION VOLTAGE WILL DAMAGE OR DESTROY THE SENSOR.

### INITIAL BRIDGE SENSOR “BALANCE” CHECK

Bridge-type sensors typically require a balance adjustment after installation, or if the sensor has drifted too far for zero calibration to be successful. To adjust the balance, access the Technician’s Menu (see Section 8.2). Select Set Balance and use the Up and DOWN keys to bring the reading close to zero.

**NOTE:** BRIDGE SENSORS DRIFT DURING WARMUP AND REQUIRE TIME TO STABILIZE (See Table).

**NOTE:** ALWAYS VERIFY SENSOR VOLTAGE **BEFORE** ADJUSTING BALANCE.

**NOTE:** MAKE SURE **NO TARGET GAS** IS PRESENT WHEN ADJUSTING BALANCE.

### LOCAL GDS-IR INFRARED SENSOR (CH 2)

When the GASMAX II is configured to include a GDS-IR Infrared Combustible or CO2 sensor, the IO/Power Supply board is factory modified to make Channel 2 compatible with the sensor's 4-20mA input signal. An integrated "zero set" pushbutton and magnetic zero switch is included inside the GASMAX II enclosure and is used to periodically set the zero point for the GDS-IR.

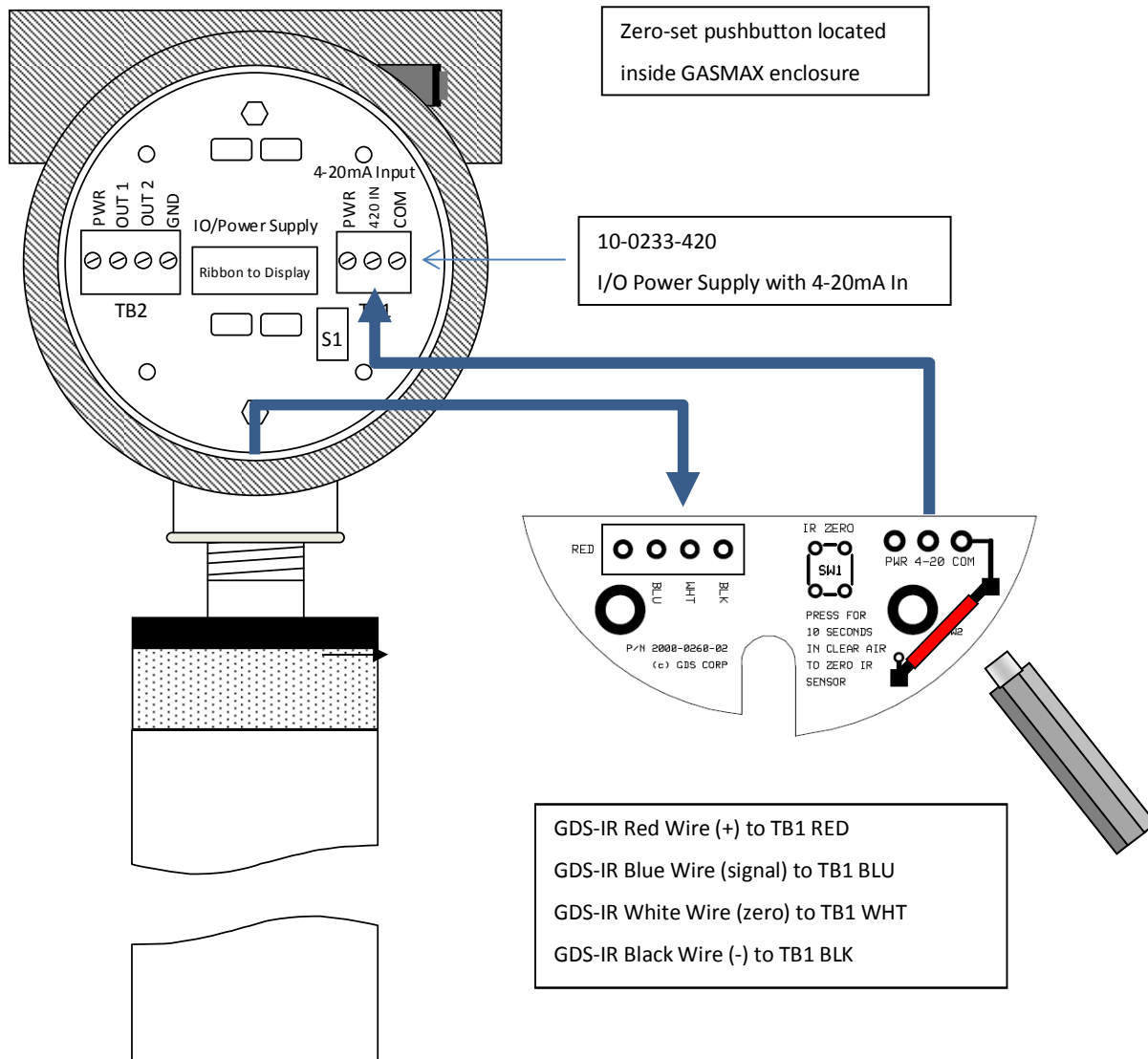

Figure 4-12: GASMAX with Local GDS-IR

### CONNECTING A REMOTE GDS-IR INFRARED SENSOR (CH 2)

GASMAX II monitors with remote-mount GDS-IR sensors are shipped in two pieces and sensor wiring must be installed by the end user. GDS-IR sensors can be mounted up to 500 feet from the GASMAX display. Cable used should be **three-wire stranded with foil shield**. GDS Corp recommends Belden B8771. The cable shield must be connected to an earth ground at ONE END ONLY. In this configuration the zero-set pushbutton is located in the GDS-IR remote mount junction box.

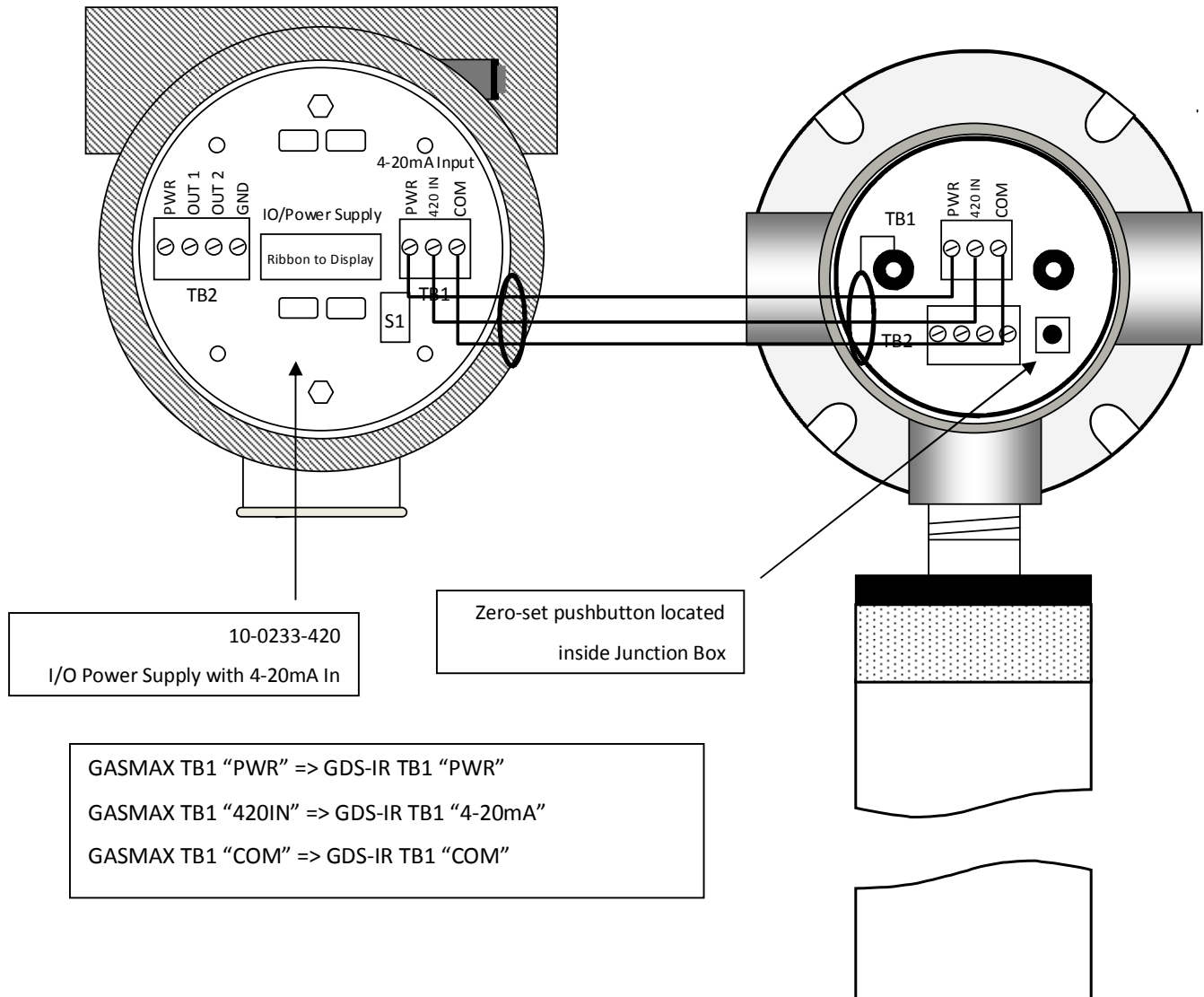
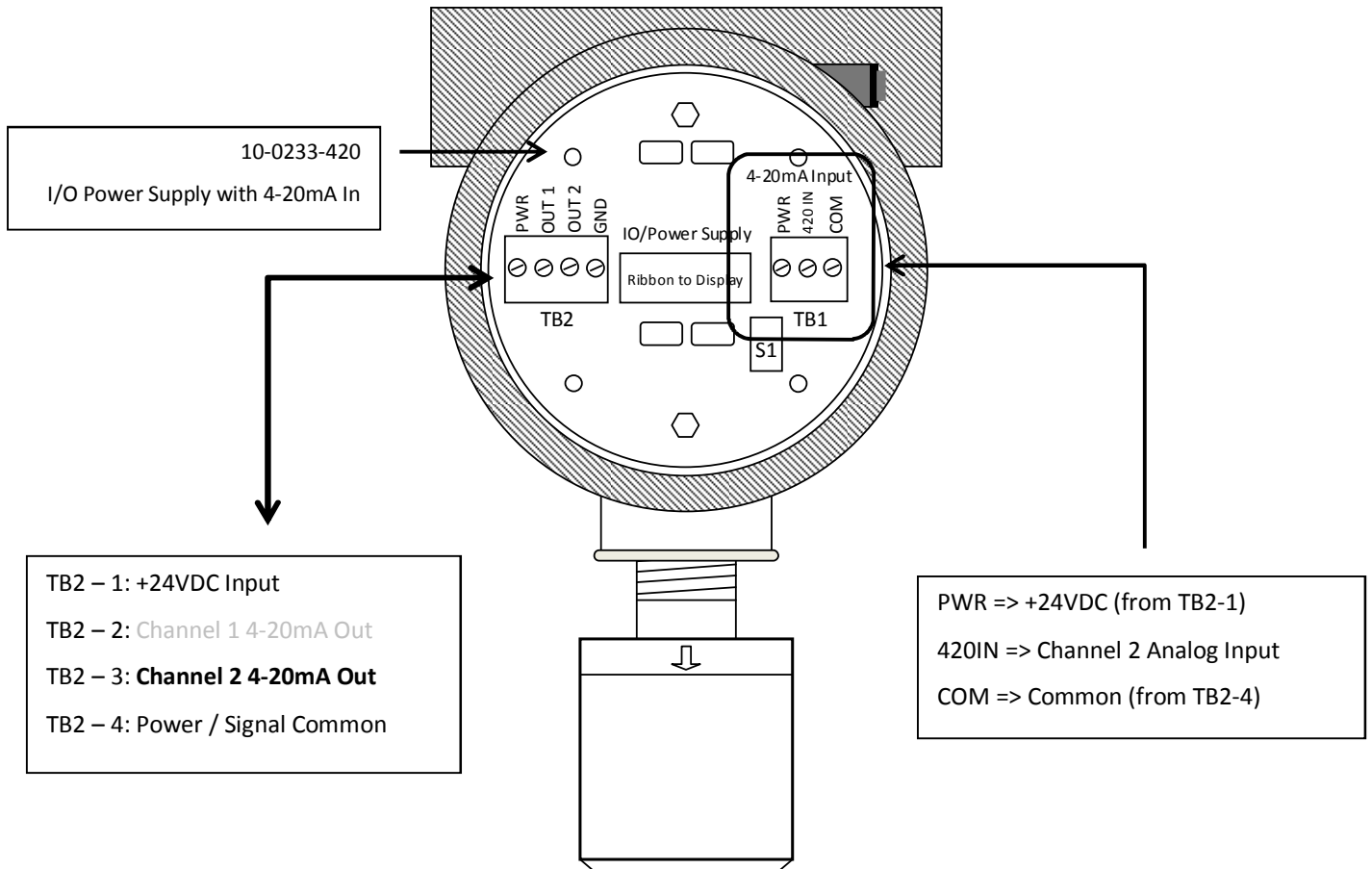

Figure 4-13: Remote GDS-IR Connection

**CONNECTING AN EXTERNAL 4-20mA INPUT DEVICE (CH 2)**

The GASMAX II can be factory configured to support a general purpose, non-isolated 4-20mA input on channel 2. Power Supply boards that have been converted to 4-20mA will have TB1 marked to indicate PWR (+24V), 4-20 IN (signal) and COM (ground). The amount of voltage and current available for the remote 4-20mA device is determined by the GASMAX DC supply connected to TB2. Note that in this case, channel 1 is still available to support a local or remote toxic sensor. The calibrated output for channel 2 is available on TB2, Pin 3.

**WARNING: IO / POWER SUPPLY BOARDS THAT HAVE BEEN CONVERTED TO 4-20MA WILL NOT SUPPORT LOCAL OR REMOTE BRIDGE-TYPE SENSORS. ATTACHING A BRIDGE-TYPE SENSOR WILL DAMAGE OR DESTROY THE SENSOR.**



**Figure 4-14: Remote 4-20mA Input (Ch 2)**

### GASMAX DUAL 4-20mA OR 4-20mA + BRIDGE INPUT OPTION

The GASMAX II can be factory configured to support two general purpose, non-isolated 4-20mA inputs on channels 1 and 2 (10-0233-D4), or one non-isolated 4-20mA input on Channel 1 and one bridge-style input on Channel 2 (10-0233-B4). Power Supply boards designed for dual 4-20mA inputs will have TB1 marked to indicate PWR (+24V), 4-20 IN 2 (signal), COM (ground) and 4-20 IN 2 (signal). The amount of voltage and current available for the remote 4-20mA device is determined by the GASMAX DC supply connected to TB2.

**WARNING: DO NOT CONNECT A BRIDGE-STYLE SENSOR TO TB1 IF THE INPUT HAS BEEN CONFIGURED FOR 4-20mA. THE +24V EXCITATION VOLTAGE WILL DESTROY THE BRIDGE-STYLE SENSOR.**

The most common usage for dual 4-20mA inputs is for use with local or remote GDS-IR Infrared Combustible Sensors or GDS-49 Remote Toxic Sensor Transmitters. Wiring examples are shown on the next page.

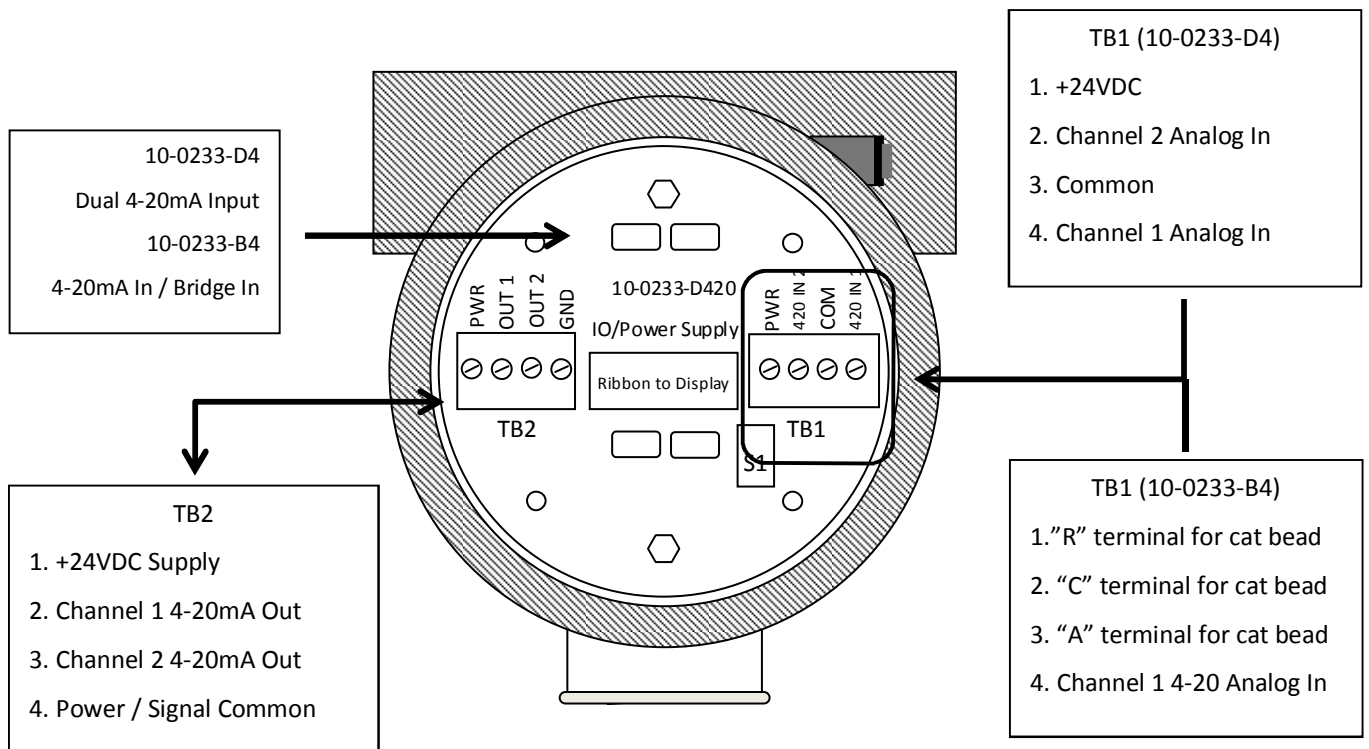

Figure 4-15: Dual 4-20mA Input Option

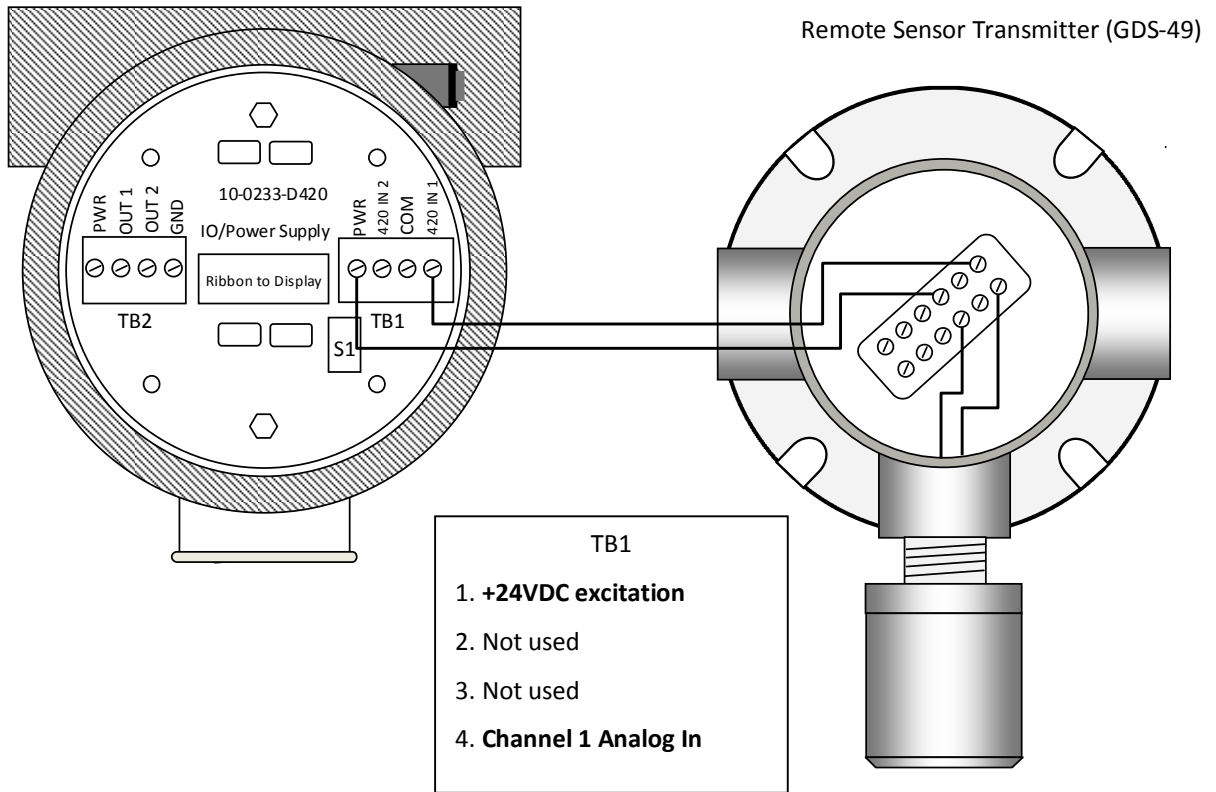

Figure 4-16: Dual 4-20mA Input



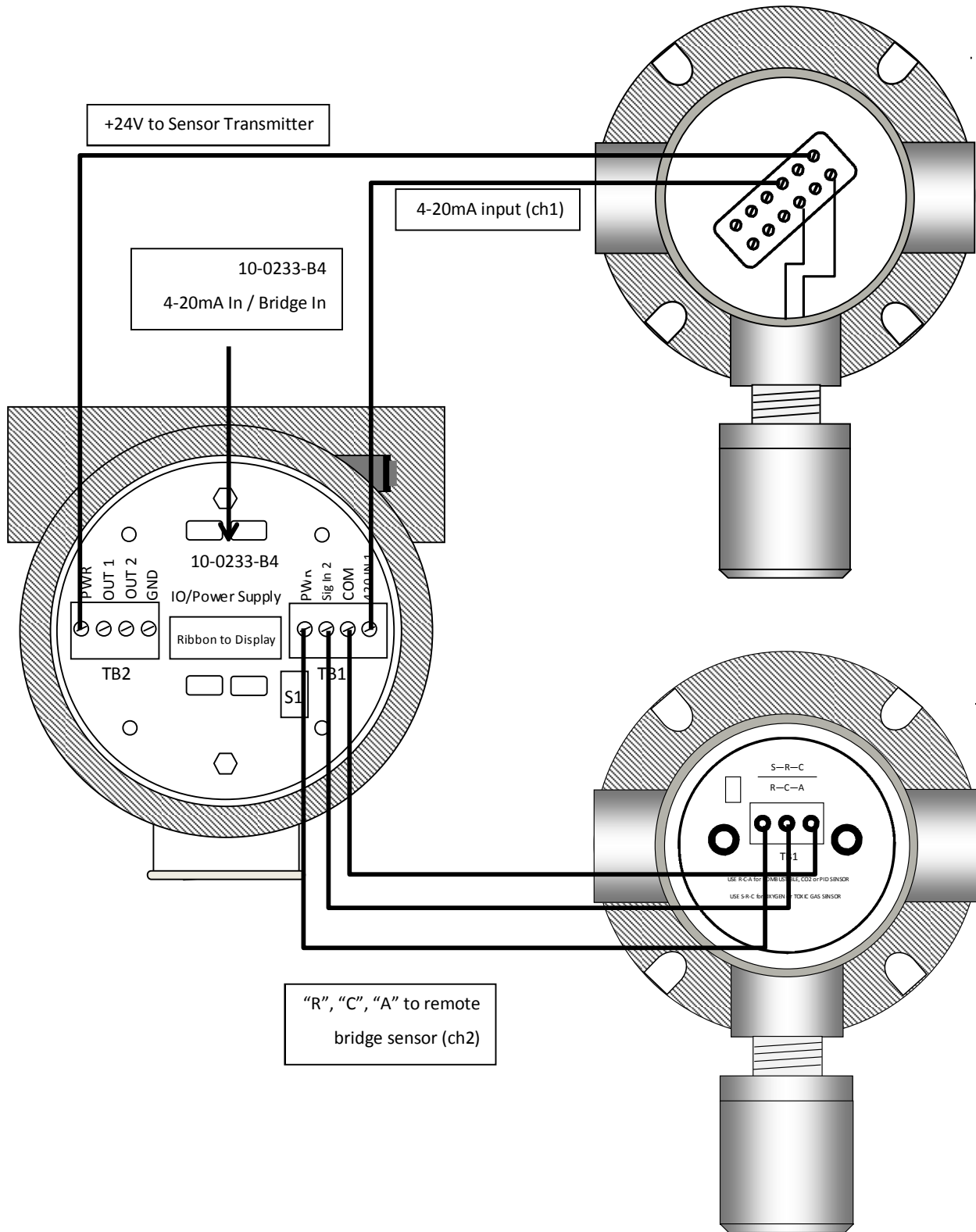

Figure 4-17: 4-20mA / Bridge Input

## **INITIAL SETUP**

Once installed, apply power to the GASMAX II and verify that the LCD display is active. Certain sensors may initially indicate off-scale high or low values, but should quickly return to zero if no target gas is present. During this warm-up delay period, the 4-20mA output is held at 4.0 mA to eliminate false alarms in any receiving devices. Warm-up delay is one of the user-adjustable parameters (see Section 7).

Once operational, the user should verify the following settings prior to initial calibration:

1. Local time and date: Check date value and adjust time for proper time zone (Sec. 7-5).
2. Tag name or Engineering Units settings: Edit values as necessary (Sec 7-2).
3. CAL SPAN GAS value: Set to match concentration of calibration gas cylinder (Sec 7-2).
4. CAL MARKER value: Adjust desired output mA during calibration (Sec 7-2).
5. ALARM 1, ALARM 2 settings: Set for desired levels. NOTE: If relays are not installed, GASMAX II programmable alarm levels affect operation of front panel LEDs only (Sec 7-3).

Allow the GASMAX II to stabilize for at least four hours, preferably overnight if possible. This will allow all sensors to reach stable equilibrium with respect to environmental conditions such as ambient temperature, humidity, and barometric pressure as well as applied “reference” and “counter” voltages generated by the GASMAX II electronics. At this point, the GASMAX II can be calibrated and made operational.

## 5 CALIBRATION

### CALIBRATION OVERVIEW

Calibration is critically important to ensure correct operation of the GASMAX II. The built-in CAL MODE function is designed to make calibration quick, easy and error free; a successful ZERO and SPAN calibration requires only four keystrokes. During CAL MODE zero and span, the sensor output is disconnected and the GASMAX II transmits a fixed mA value, called the CAL MARKER, to notify the receiving device that a calibration is in progress. During the following CAL PURGE DELAY time, the GASMAX II transmits a fixed 4.0 mA signal to prevent external alarms during calibration. In the case of local or remote Oxygen sensors, during CAL PURGE DELAY the output simulates a typical atmospheric reading of 20.8%. CAL MODE automatically exits if no keystrokes are detected after 5 minutes.

Follow these GASMAX II calibration guidelines:

- Calibration accuracy is only as good as the calibration gas accuracy. GDS Corp calibration gases are traceable to NIST (National Institute of Standards and Technology).
- **Never use calibration gas that has passed its expiration date.**
- Check the SPAN GAS VALUE setting and make sure it matches the calibration gas. (See Fig. 6-2)
- Always use a GDS Corp calibration cup that completely surrounds the sensor head.
- Be sure to use ZERO AIR, a mixture of 21% oxygen and 79% nitrogen, as a zero reference unless you are certain that no target gas exists in the area. Ambient gas may result in an 'elevated zero' condition that will cause a FAULT to occur once the ambient gas is no longer present.
- **Always calibrate a new sensor before depending on the device for personnel or equipment safety**
- Calibrate on a regular schedule. GDS Corp recommends a full calibration every 3 months, with periodic 'bump tests' on a more frequent basis to ensure that the sensor has not been affected by temperature extremes or the presence of incompatible gases.

## CALIBRATION PROCEDURE

Before beginning calibration, make sure you have the following items: A cylinder of calibration gas, fixed flow regulator and an appropriate calibration cup connected to the regulator via a length of flexible tubing. If necessary, a cylinder of 'zero air' may be necessary if the absence of target gas cannot be confirmed. GDS Corp recommends a flow rate of 0.5 liters / minute for standard gases and a flow rate of 1.0 liters / minute for highly reactive gases such as chlorine or chlorine dioxide.

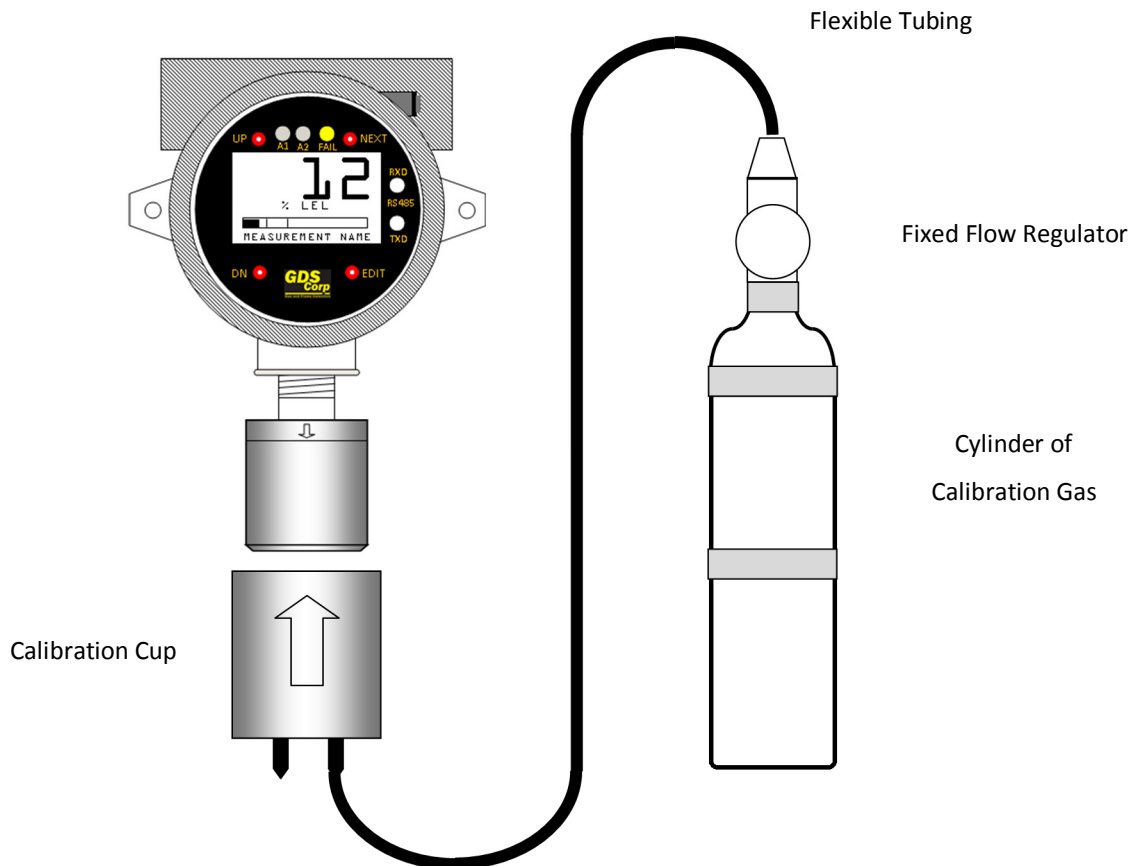

To calibrate a GASMAX II detector:

1. For dual channel units, press the NEXT key until that the DATA Display screen for the desired channel is shown.
2. To enter CAL MODE, press the DOWN / CAL key and within 5 seconds press the EDIT key.
3. The screen will display an APPLY ZERO message. Using the setup shown in Fig. 5-1, apply clean ZERO air unless it can be guaranteed that no target gas is present. After the reading stabilizes, press the EDIT key to complete the ZERO calibration.
4. If the ZERO CAL SUCCESSFUL message is displayed, an APPLY SPAN message will appear. Apply the correct SPAN gas. After the reading is stable, (approximately 1 minute) press the EDIT key to

complete the SPAN GAS calibration. If the SPAN calibration is successful, the display flashes REMOVE CAL GAS and starts the CAL PURGE delay.

5. Immediately shut off the regulator and remove the calibration cup. At the end of the CAL PURGE delay, the GASMAX EC output is re-enabled and the unit is fully operational.

The flow chart shown in Figure 5-2 illustrates the above procedure. UP, CAL, NEXT & EDIT labels indicate keystrokes using the magnetic wand. ZERO or SPAN calibration will fail if the readings exceed built-in limits for maximum allowable zero or minimum allowable span.

**NOTE: A CAL MODE INFO SCREEN IS AVAILABLE TO VIEW CERTAIN CAL MODE PARAMETERS DURING CALIBRATION. HOLD THE UP KEY FOR 5 SECONDS DURING CAL MODE TO DISPLAY THIS SCREEN.**

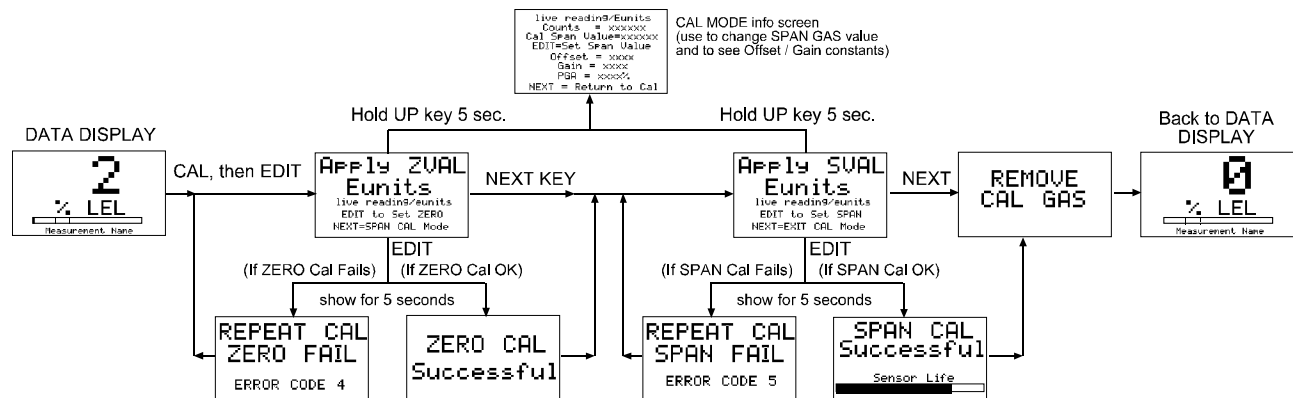

Figure 5-1: Calibration Flowchart

## 6 OPERATION AND MAINTENANCE

### NORMAL OPERATING MODE

During normal operation, the GASMAX display shows the current gas reading in direct calibrated engineering units. If the reading goes above the Alarm 1 or Alarm 2 values, the front panel display LEDs will flash and the internal relays, if installed and programmed properly, will activate. The 4-20mA outputs will transmit values that represent the % of scale shown on the display. If the sensor malfunctions, or is removed, the Fault LED will illuminate and the message FAULT will appear on the display screen.

### ALARM OPERATION – ALARM 1 AND 2

GASMAX II gas monitors have front panel LED indicators for ALARM 1 and ALARM 2. Both alarm indicators can be set to activate above or below a given engineering units set point. Alarm processing will trigger an alarm condition when the input exceeds the programmed value, and includes hysteresis to keep the alarm from rapidly switching ON and OFF if the input remains close to the programmed alarm value.

**NOTE: ALARM RELAYS ARE NORMALLY TRIGGERED IF EITHER CHANNEL 1 OR CHANNEL 2 ALARM THRESHOLDS ARE EXCEEDED.**

**NOTE: IF THE OPTIONAL ALARM RELAYS ARE NOT INSTALLED, ALARM SETTINGS AFFECT THE OPERATION OF THE FRONT PANEL LEDS ONLY. SEPARATE ALARM SETTINGS MAY NEED TO BE PROGRAMMED IN THE 4-20MA RECEIVING DEVICE.**

### ALARM OPERATION – ALARM 3

ALARM 3 is typically used to indicate FAULT conditions that suggest sensor failure or “out of measurement range” conditions. However, some applications require a third level alarm. The ALARM 3 menu is identical to ALARM 1 and ALARM 2 and may be set to trip at any level.

**NOTE: ALARM 3 WILL ALSO TRIP WITH MISSING OR FAILED SENSORS REGARDLESS OF THE PROGRAMMED LEVEL VALUE.**

### SENSOR REPLACEMENT – LOCAL SENSORS

If a sensor shows FAULT, does not respond to gas or can no longer be calibrated, it should be replaced. GASMAX II monitors use GDS Corp type 10-95XX toxic or combustible sensors, where the XX is the gas type, or GDS-IR infrared sensors. For toxic or combustible sensors, the range value should also be specified when ordering replacement sensors. For example, a replacement H<sub>2</sub>S sensor for 0-100 ppm would be “10-9515-R0100”.

To replace a GASMAX local sensor:

1. Declassify the area or remove power to the GASMAX II.

2. Unscrew the sensor head cover. If unable to open the cover by hand, use a Sensor Head Replacement Tool (p/n 10-0187).
3. Remove the old sensor by pulling straight down.  
**NOTE: DO NOT TRY TO UNSCREW THE SENSOR. PULL STRAIGHT DOWN!**
4. Carefully install the replacement sensor by aligning the arrow on the sensor with the arrow engraved on the sensor head. Push straight up until the sensor connector seats firmly into the sensor connector.
5. Reinstall the sensor head cover by CAREFULLY screwing the cover onto the sensor head.  
**NOTE: IF THE SENSOR FALLS OUT OF THE SOCKET DURING THIS STEP, IT CAN BE DAMAGED. USE CAUTION WHEN REINSTALLING THE COVER.**

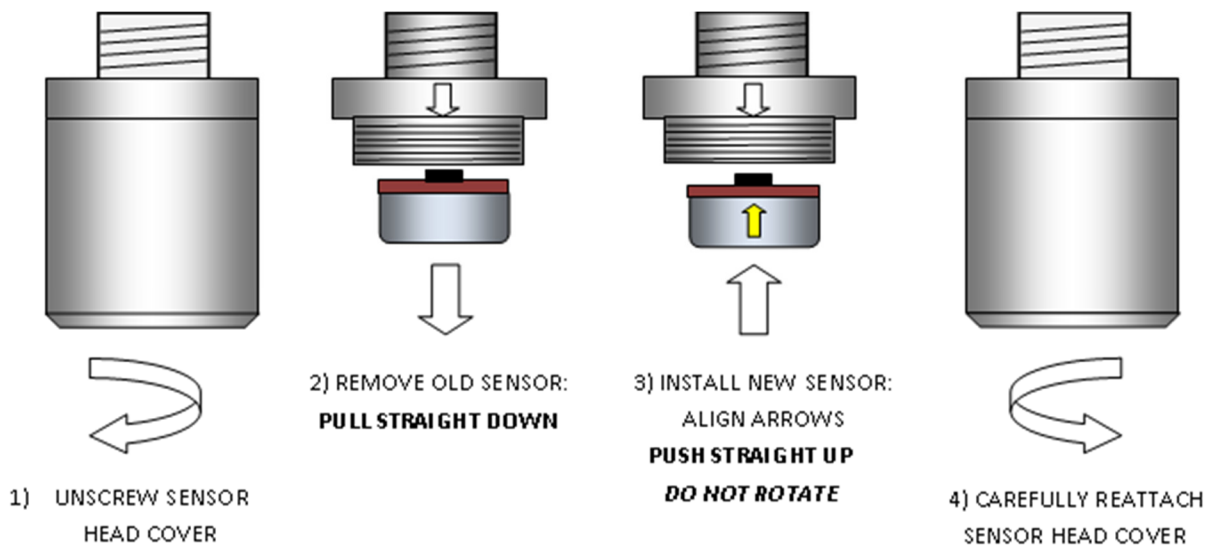

**Figure 6-1: GASMAX Sensor Replacement**

Local Smart Sensors are automatically recognized by the GASMAX II and the Smart Sensor identification screen shown in Figure 6-1 (left side) should appear immediately after the installation of a local Smart Sensor. If the sensor is the same gas type as was previously installed, the sensor's calibration data will be uploaded into the GASMAX II. All other parameters stored in the GASMAX II will be retained.

GASMAX II units can be reconfigured for different sensors by simply installing a different type compatible sensor. If a new sensor TYPE is installed, the Smart Sensor identification screen will appear, followed by the ERROR CODE 01 message and the user will be given the opportunity to confirm the new sensor type. If

the user activates the EDIT key, all data stored in the new sensor's database – including range, tag name, cal span value, engineering units and alarm levels – will replace the current settings.

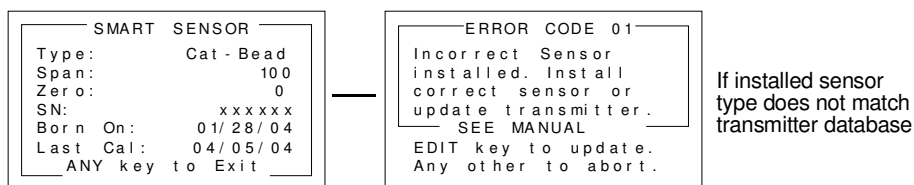

Figure 6-2: SMART SENSOR Recognition Screen

### SENSOR REPLACEMENT – REMOTE SENSORS

To replace a GASMAX remote sensor:

1. Declassify the area or remove power to the GASMAX II.
2. Unscrew the sensor head cover. If unable to open the cover by hand, use a Sensor Head Replacement Tool (p/n 10-0187).
3. Remove the old sensor by pulling straight down.  
**NOTE:** DO NOT TRY TO UNSCREW THE SENSOR. PULL STRAIGHT DOWN!
4. Carefully install the replacement sensor by aligning the arrow on the sensor with the arrow engraved on the sensor head. Push straight up until the sensor connector seats firmly into the sensor connector.
5. Reinstall the sensor head cover by CAREFULLY screwing the cover onto the sensor head.  
**NOTE:** IF THE SENSOR FALLS OUT OF THE SOCKET DURING THIS STEP, IT CAN BE DAMAGED. USE CAUTION WHEN REINSTALLING THE COVER.
6. At the GASMAX II, activate the Main Menu, open the Sensor Information page and select Install New Sensor. This will reset the Sensor Life settings and tell the GASMAX that a new sensor is available.

### NORMAL MAINTENANCE

Normal maintenance for the GASMAX II primarily involves periodic calibration on standard intervals. GDS Corp recommends calibration at least every three months, or more often if temperature extremes, vibration, the presence of incompatible gases or other environmental factors may accelerate the deterioration of the sensor element. Calibration should also include inspections for clogged or wet sensor heads, cracked or damaged enclosures and water incursion inside conduit or junction boxes.



## 7 USER MENUS

### MAIN MENU

GASMAX II setup variables are stored in non-volatile memory and can be modified by the end user to better match a particular application. The GASMAX II Main Menu tree is shown below. To access the Main Menu, swipe the magnetic wand over the EDIT key.

Pressing EDIT from either data display enters the LEL or EC SETUP PAGE 1 menu.

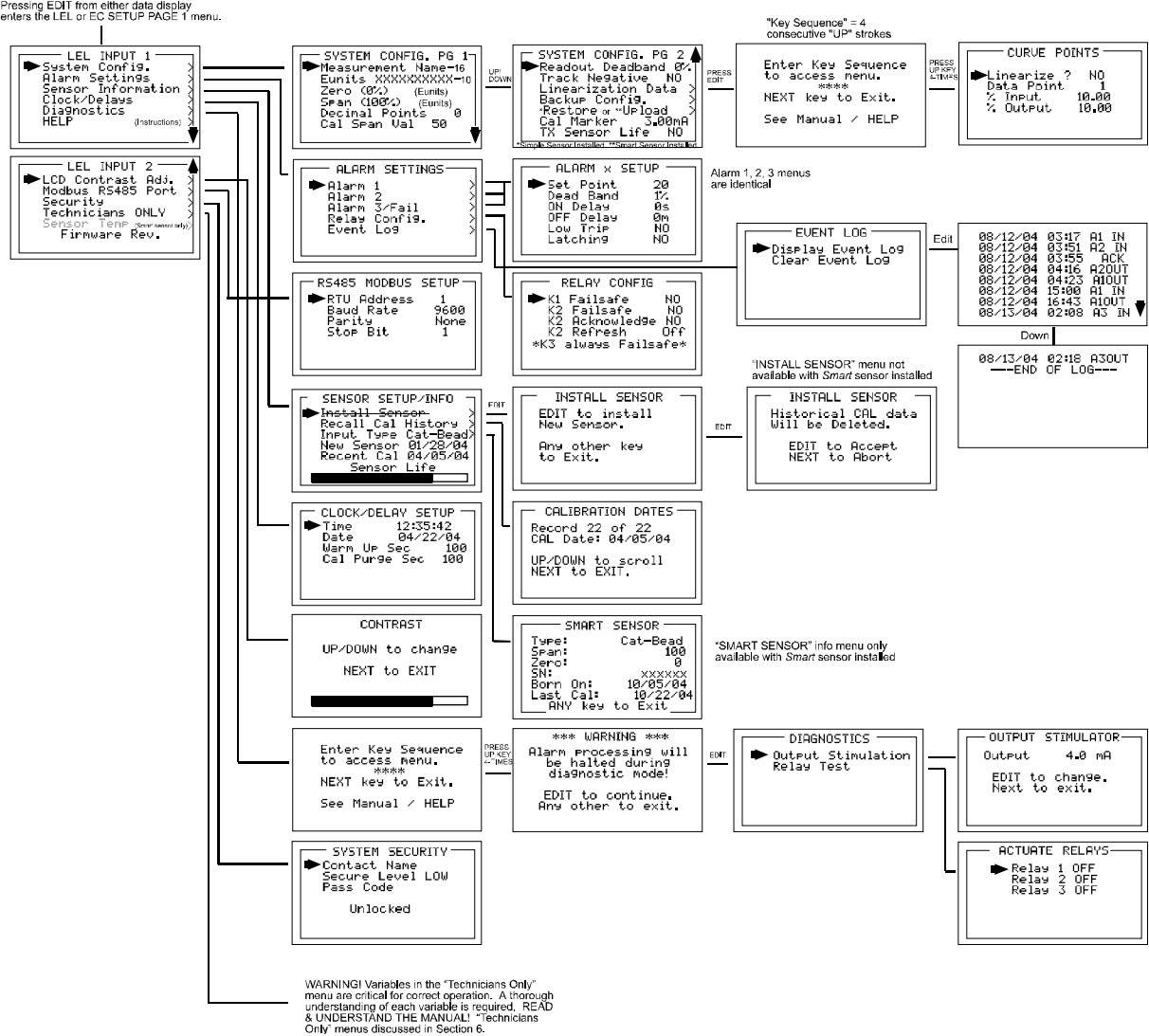

**Figure 7-1: MAIN MENU FLOWCHART**

## SYSTEM CONFIGURATION PAGE

The System Config group consists of two pages of menus as shown in Figure 6-2. Each item's description follows in this section.

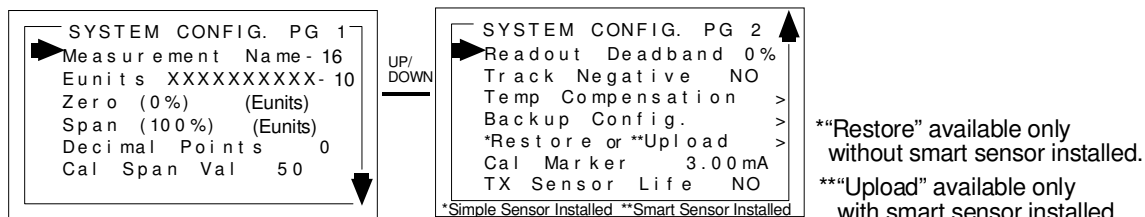

Figure 7-2: SYSTEM CONFIG MENU

**MEASUREMENT NAME** may be edited to contain virtually any 16-character field and is typically used to describe the monitored point by user tag number or other familiar terminology. To modify the existing setting, press the EDIT key when the cursor is pointing to the entry. Use the UP or DN keys to change the character, and the NEXT key to move to the next character. Press EDIT again when done.

**EUNITS** (engineering units) may have up to a 10 character ASCII field. Many common gases have pre-configured Eunits based upon the sensor type and each may be edited in this menu as described in Configuration Using the Magnetic Wand section 5-2.

**ZERO (0%)** defines the reading to be displayed when 4mA (0%) is the GASMAX II output.

**SPAN (100%)** defines the reading to be displayed when 20mA (100%) is the GASMAX II output. The highest reading allowed is 9999 including negative polarity sign. Polarity is only indicated for negative readings.

**DECIMAL POINTS** set the resolution of the LCD readings and may be set for 0, 1 or 2. For example, ZERO readings for 0, 1 & 2 decimal points displays as “0”, “0.0” & “0.00”.

**CAL SPAN VALUE** sets the engineering units value of the calibration gas. GDS Corp recommends that the calibration gas value be between 25% and 75% of full scale. Calibrating at 100% of scale is not recommended.

**READOUT DEADBAND** forces low values to continue to read zero. This is useful when there are small amounts of background gases that may cause fluctuating readouts. The highest amount of deadband allowed is 5%.

**NOTE:** THE 4-20MA OUTPUT IS NOT AFFECTED BY THIS SETTING.

**TRACK NEGATIVE** allows the display to show negative values when set to “YES”. This can be helpful when troubleshooting sensor problems. The default setting is “NO” and forces the display to read “0” if

the sensor value drops below zero. However, negative sensor outputs will always cause the Fault alarm to trip. The 4-20mA output always locks at 4mA when the reading drifts negative.

**TEMP COMPENSATION** adjusts sensor output based on ambient temperature. GDS Corp temperature compensated sensors are preprogrammed with the necessary table of values and are automatically uploaded to the GASMAX II from the smart sensor. This menu item is not accessible unless a temperature compensated local Smart Sensor is installed.

**BACKUP CONFIG** allows users to store the entire current GASMAX II menu database into non-volatile memory for restoration later if incorrect values are accidentally entered or uploaded.

**RESTORE CONFIG** restores the GASMAX II menu database to the values from the most recent Backup Config. This menu item is only available if a smart sensor is not installed. The special keystroke sequence of 4 consecutive UP keys is also required to perform backup and restore operations.

**UPLOAD SENSOR DATA** allows the user to manually upload the entire smart sensor database to the GASMAX II from the smart sensor.

**CAL MARKER** allows the user to set the 4-20mA output value that is transmitted during ZERO and SPAN calibration. This setting is limited to between 2ma and 20mA and is a useful way to indicate to a GDS controller that the unit is in CAL MODE.

**TX SENSOR LIFE** causes the GASMAX II 4-20mA output to transmit a "sensor life" value after the completion of a successful calibration cycle. During normal operation, the GASMAX II transmits a 4mA signal during the CAL PURGE delay to allow time for the span gas to dissipate. With TX Sensor Life = YES, the GASMAX II transmits 4mA for the first 10 seconds, then for 5 seconds transmits a value between 4mA and 5mA, with 4mA equal to 0% sensor life and 5mA equal to 100% sensor life (see Figure 5-5). The output then returns to 4mA for the remainder of the CAL PURGE delay. For example, if after a calibration sensor life is 75%, the GASMAX II transmits 4.75mA during the 5-second interval

**NOTE:** TX SENSOR LIFE SHOULD ALWAYS BE SET FOR **NO** UNLESS THE 4-20MA RECEIVER IS CAPABLE OF INTERPRETING THE SENSOR LIFE SIGNAL. MOST GDS CORP *PROTECTOR* SERIES CONTROLLERS INCLUDE THIS CAPABILITY.

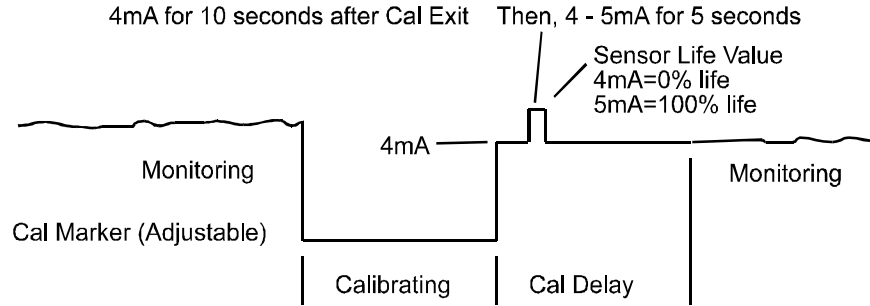

Figure 7-3: SENSOR LIFE TRANSMISSION FORMAT

### ALARM SETTINGS PAGE

The Alarm Settings page covers the Alarm 1, 2, 3 Setup and Event Log menu items. Alarm 1, Alarm 2 and Alarm 3/Fail menus are identical and are therefore described only once. If the optional alarm relays are not installed, the alarm settings only affect the operation of the front panel LEDs. In that case, separate alarm settings may need to be programmed in the 4-20mA receiving device.

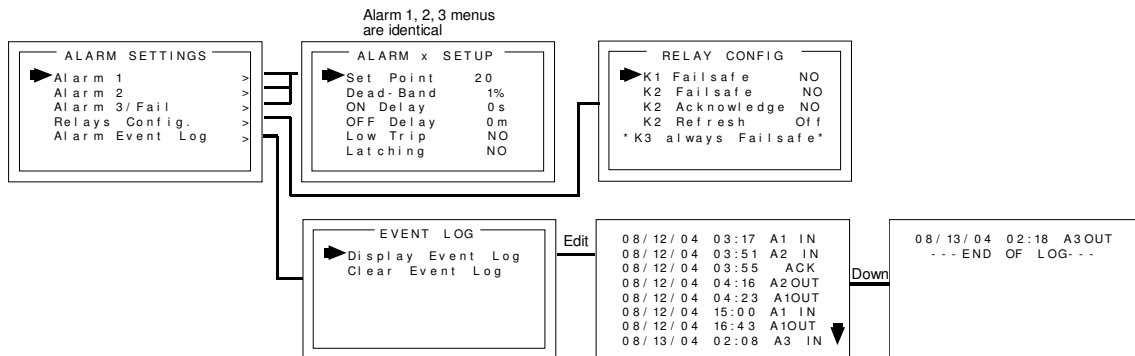

Figure 7-4: ALARM SETTINGS MENU

**SET POINT** enters the engineering unit value where the alarm trips. It may be negative and trip when monitored values fall out of range in this direction. A3 has a default setting of negative 10 with Low Trip set for YES. This makes it function as a FAULT alarm and trip when the monitored value falls below “-10”. It is important to adjust this value when the transmitter’s span value is set for another value other than 100. For example, a typical span setting for monitoring oxygen level is 0-25.0(%), therefore the fault level value should be adjusted to -2.5 which is equivalent to negative 10% of full scale.

**DEAD-BAND** has a minimum value of 1% and a maximum value of 10%. It is useful for preventing alarm cycling when the monitored value is hovering around the set point.

EXAMPLE: With a range of 0-100 ppm, if Dead-Band equals 5% and the set point is 20 ppm, after tripping at 20 ppm the value must drop below 15 ppm to reset.

**ON DELAY** allows entering a maximum 10 second delay before this alarm becomes active. This is useful for preventing nuisance alarms caused by brief spikes beyond the set point.

**OFF DELAY** allows entering a maximum 120 minute delay before clearing an alarm after the alarm condition is gone. This is useful for continuing an alarm function, such as operation of an exhaust fan, for a period of time after the alarm condition clears.

**LOW TRIP** set to YES causes the alarm to trip as the value falls below the set point.

**LATCHING** set to YES causes the alarm to remain active even after the condition is gone and only reset when the UP / RESET key is pressed from a data display.

**DISPLAY EVENT LOG** displays the stored events in the Event Log. These include power-on, cold-boot, alarms and alarm acknowledge events. The event log stores the date and time of the most recent 300 events.

**CLEAR EVENT LOG** clears the event log.

### **RS-485 COMMUNICATIONS**

The RS-485 MODBUS SETUP menu allows setting the RTU address (if RS-485 equipped) for each GASMAX on the RS-485 network. Each GASMAX must have a different RTU address when communicating on the same 2-wire cable RS-485 loop. Baud rate, Parity and Stop Bit are fixed at industry standard values of 9600 baud, No Parity and One Stop Bit.

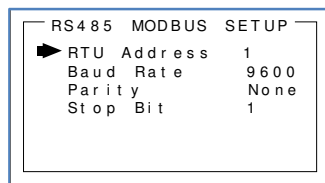

**Figure 7-5: RS-485 MODBUS Menu**

### **SENSOR SETUP**

The Sensor Information page covers settings associated with Smart or simple sensors. Users can review information contained in the Smart Sensor database, or adjust settings for remote simple sensors.

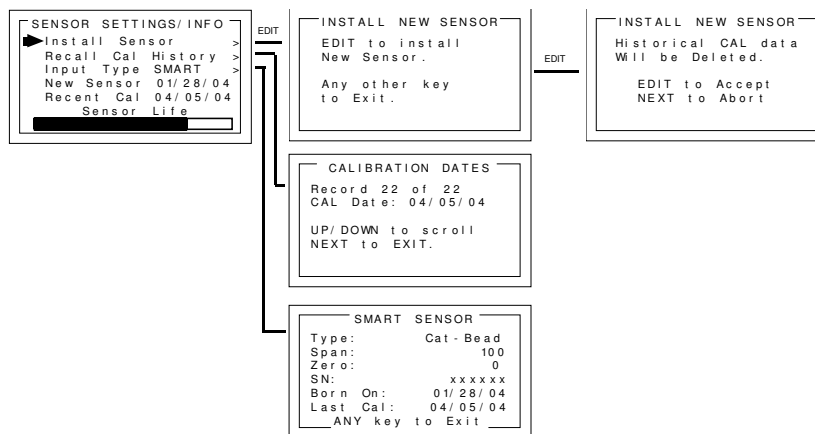

**Figure 7-6: SENSOR SETTINGS MENU**

**INSTALL NEW SENSOR** should always be performed when a new simple sensor is installed. This deletes historical CAL data and sets sensor life to 100% after initial calibration of the new simple sensor. The GASMAX II Smart Sensor interface will automatically detect new Smart Sensors and this menu is therefore not available with a Smart Sensor connected.

**RECALL CAL HISTORY** recalls each successful calibration. These dates may be reviewed by scrolling with the UP / DOWN keys.

**INPUT TYPE** indicates what kind of input or sensor the GASMAX II is configured to accept and is typically pre-configured at the factory. When installed, Smart Sensors upload sensor type and other data to the GASMAX II and this data may be viewed on the SMART SENSOR information screen.

**NEW SENSOR** displays the date when a new sensor was last installed.

**RECENT CAL** displays the most recent calibration date.

### CLOCK / DELAY SETUP PAGE

The GASMAX II is equipped with a crystal-controlled, battery-backed real-time clock that maintains local Time and Date. These values are factory preset to US Central Time and should be reset to correctly match the current time zone during installation to make sure that time-stamped Event Log entries are correct.

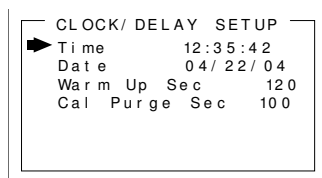

**Figure 7-7: CLOCK DELAY MENU**

**TIME** adjusts time of day in hours, minutes and seconds.

**DATE** adjusts date in month, day, year.

**WARM UP DELAY** sets the amount of time from power-on until the 4-20mA output signal begins to track the sensor output. Default setting is 60 seconds. Maximum value is 255 seconds.

**CAL PURGE DELAY** sets the amount of time from the completion of span calibration until the 4-20mA output signal restarts tracking the sensor output. The default setting is 60 seconds and the maximum value is 255 seconds.

### LCD CONTRAST ADJUSTMENT PAGE

The LCD Contrast Adjustment allows the display to be set for optimum viewing.

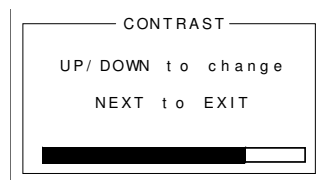

Figure 7-8: CONTRAST MENU

### HELP SCREEN PAGE

The Help screen contains several pages of information describing GASMAX II operation.

### DIAGNOSTICS PAGE

The Diagnostics page provides tools for use during setup or testing. Since relays are not available on the GASMAX II, the Relay Test option is not functional.

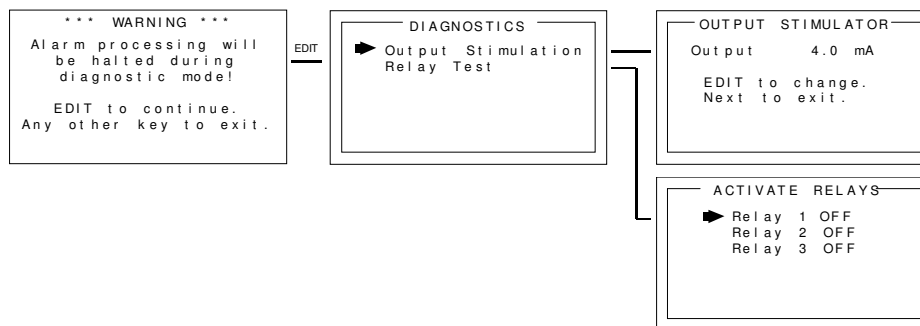

Figure 7-9: DIAGNOSTICS MENU

**OUTPUT SIMULATION** allows setting the 4-20mA output to virtually any desired value. This is useful for checking responses of devices receiving the GASMAX II's 4-20mA output.

**RELAY TEST** allows the user to manually activate any of alarm relays independent of the presence of gas. This is useful during troubleshooting or initial installation when an end-to-end test of relay functionality must be done.

**WARNING:** TARGET GAS MONITORING AND ALARM PROCESSING ARE NOT ACTIVE WHILE IN THIS MENU.

### SYSTEM SECURITY PAGE

The System Security menu offers two levels of protection against operation by unauthorized personnel or those with malicious intent.

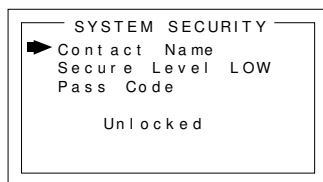

**Figure 7-10: SYSTEM SECURITY MENU**

**CONTACT NAME** is a 12 character ASCII field available for displaying a phone # or name of personal who knows the Pass Code. Lost Pass Codes may be recovered by entering the locked security menu and holding the UP key for 5 seconds. The 4-digit code appears near the bottom of the screen.

**SECURE LEVEL** sets LOW, HIGH or OFF modes. A LOW level allows CAL MODE sensor calibrations but requires the 4-digit Pass Code prior to altering menus. HIGH level locks the entire menu database and the CAL Mode until the correct Pass Code is entered. LOW and HIGH security levels always allow static viewing of configuration menus.



## 8 TECHNICIANS MENU

The TECHNICIANS MENU group consists of the XMITTER CONFIG menu and TECHNICAL PAGE menu. These menus contain items that are typically factory configured depending upon the type sensor and input connected. Care should be used when modifying these variables as some items will prevent proper operation and could endanger personnel. Access requires a special key sequence of four UP keystrokes to prevent accidental modification of critical items.

### XMITTER CONFIG MENU

The XMITTER CONFIG menu is used to activate channels, precisely calibrate 4-20mA outputs and set time / date. To access the XMITTER CONFIG menu, press and hold the NEXT key for 5-seconds until the screen appears requesting the special key sequence.

**WARNING: TARGET GAS MONITORING AND ALARM PROCESSING ARE NOT ACTIVE WHILE IN THIS MENU.**

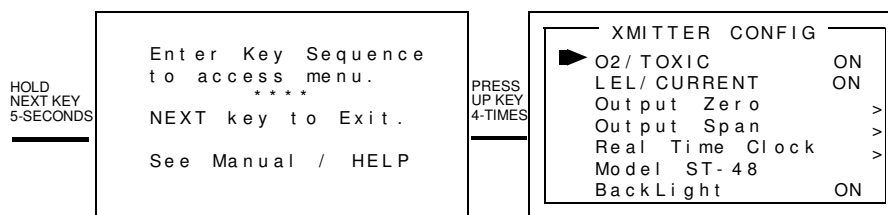

Figure 8-1: XMITTER CONFIG MENU

**O2 / TOXIC** when set to YES enables the Oxygen / Toxic channel (Channel 1).

**LEL / CURRENT** when set to YES enables the LEL / Current channel (Channel 2).

**OUTPUT ZERO / SPAN TRIM** provides a way to precisely set the GASMAX II 4mA and 20mA outputs to compensate for variation in output components. These settings are programmed at the factory and should not be modified.

**REAL TIME CLOCK** adjusts the date and time for use in EVENT LOGGING. The current time and date can also be adjusted from the Main Menu (See Section 7).

**MODEL** is factory set and should not be modified.

**BACKLIGHT** is not available in the GASMAX II.

## TECHNICAL PAGE MENU

The TECHNICAL PAGE menu is used to adjust certain parameters associated with local or remote sensors. To access the TECHNICAL PAGE menu, enter the Main Menu, move the cursor to the second page and select Technicians Only. Enter the key sequence (four “UP” keys) to activate the TECHNICAL PAGE menu.

**WARNING: TARGET GAS MONITORING AND ALARM PROCESSING ARE NOT ACTIVE WHILE IN THIS MENU.**

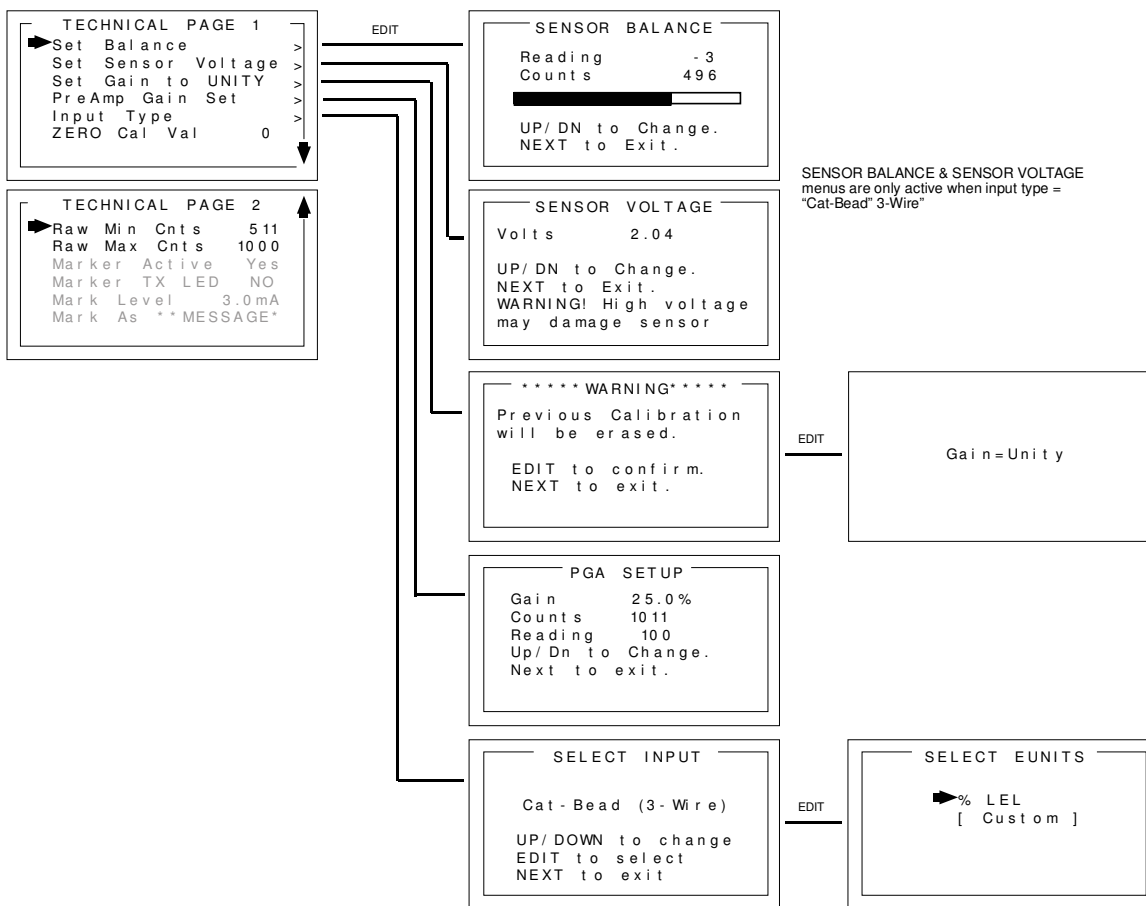

**Figure 8-2: TECHNICAL PAGE MENU**

**SET BALANCE** adjusts the balance of a bridge-type sensor and must only be performed with ZERO gas on the sensor. Balance is similar to a very coarse ZERO calibration and does not need to be precise since subsequent calibrations will correct for small errors. ZERO gas applied to the sensor should provide a Reading of -3 to +3 on the SENSOR BALANCE menu.

**SET VOLTAGE** adjusts the excitation voltage applied to bridge type sensors and may vary from 2 to 6 volts. Local Smart Sensors automatically adjust the excitation voltage to match the needs of the sensor.

Remote sensors require manual adjustment. Excitation voltage must be measured **at the sensor**; therefore, if the sensor is mounted some distance away from the GASMAX II, the excitation voltage may have to be higher to compensate for losses in field wiring.

**WARNING: EXCEEDING A SENSOR'S RATED EXCITATION VOLTAGE MAY DAMAGE OR DESTROY THE SENSOR.**

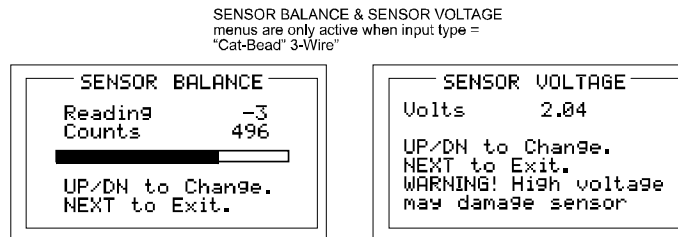

**Figure 8-3: Sensor Balance & Voltage Set Menu**

**SET GAIN TO UNITY** clears any previous calibration OFFSET and GAIN values to "0.0" and "1.0", respectively. This item is useful if a previous calibration was done in error, or if screen readings appear incorrect for no apparent reason.

**WARNING: A FULL CALIBRATION SHOULD ALWAYS BE PERFORMED AFTER A SET UNITY COMMAND.**

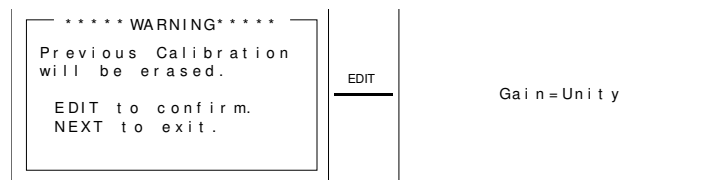

**Figure 8-4: SET GAIN TO UNITY MENU**

**PREAMP GAIN SET** allows adjustment of the analog amplifiers that match the sensor output to the optimum input range for the GASMAX II signal conditioning circuits. Local Smart Sensors include factory-preset preamp gain values and for standard sensors and applications, these values should not be changed. For remote simple sensors or for situations where a local Smart Sensor does not quite provide enough signal to successfully complete a SPAN calibration, the Preamp gain can be adjusted using the UP / DOWN keys. GDS Corp does not recommend adjusting the Preamp Gain to any value higher than 85%.

**WARNING: A FULL CALIBRATION SHOULD ALWAYS BE PERFORMED AFTER ANY CHANGE IN THE PREAMP GAIN SETTING.**

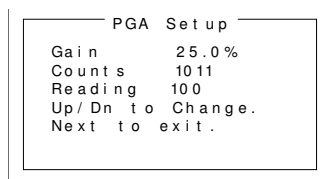

**Figure 8-5: PREAMP GAIN SET MENU**

Simple Sensor Input Type Local Smart Sensors automatically configure Input Type to match sensor requirements. However, when using remote sensors, Input Type must be set manually. Input Type is factory preset and should not be changed unless a different TYPE remote sensor is to be installed. Input Type configures GASMAX II hardware to accept bridge sensors, positive coefficient electrochemical sensors, negative coefficient electrochemical sensors or 4-20 mA inputs. After selecting Input Type, a SELECT EUNITS screen indicates the default engineering units for this sensor.

Coefficient	Electrochemical Sensor Type	Default EUNITS
Negative	Hydrogen Sulfide	ppm H2S
Negative	Oxygen	% Oxygen
Negative	Carbon Monoxide	ppm CO
Negative, Bias	Ammonia	ppm NH3
Negative, Bias	Nitric Oxide	ppm NO
Negative	Ethylene Oxide	ppm Eth O2
Negative	Hydrogen Chloride	ppm HCL
Negative	Hydrazine	ppm N2H4
Negative	Arsine	ppm Arsine
Negative	Sulfur Dioxide	ppm SO2
Negative	Hydrogen	ppm H2
Negative	Hydrogen Cyanide	ppm HCN
Negative	Phosgene	ppm COCl2
Negative	Phosphine	ppm PH3
Negative	Hydrogen Fluoride	ppm HF
Positive	Nitrogen Dioxide	ppm NO2
Positive	Ozone	ppm Ozone
Positive	Chlorine	ppm Cl2

**ZERO CAL VALUE** should always be set to “0”.

**RAW MIN / MAX COUNTS** is factory preset and should not be changed.

**MARKER ACTIVE** enables an input level monitor on the channel 2 input if the input is set to accept a 4-20mA signal. If Marker Active is set the YES, the following actions may be programmed to occur when the input signal matches the Marker Level setting.

**MARKER TX LED** will cause the TX LED to illuminate if the 4-20mA input matches the Marker Level setting.

**MARK LEVEL** is the value at which the Marker is active. The input must be within +/- 1% of this value to be active. Setting is in mA.

**MARK AS MESSAGE** is a text message string that appears on the LCD when the input level matches the Marker Level setting.

## 9 MODBUS REGISTERS

The GASMAX II features a full complement of user-accessible MODBUS registers that can provide a complete snapshot of each gas detectors configuration. This includes all real-time data, preset zero, span and calibration values and user-programmable text.

### LIST OF GASMAX II MODBUS VARIABLES

Variable Name	Alias	Read FC	Write FC	Notes
Ch 1 Alarm 1	2001	2	N/A	Modbus Coils (read only)
Ch 1 Alarm 2	2002	2	N/A	
Ch 1 Fault	2003	2	N/A	
Ch 2 Alarm 1	2004	2	N/A	
Ch 2 Alarm 2	2005	2	N/A	
Ch 2 Fault	2006	2	N/A	
K1 (Relay 1)	2007	2	N/A	
K2 (Relay 2)	2008	2	N/A	
K3 (Relay 3)	2009	2	N/A	
Ch 1 Cal Mode	2010	2	N/A	
Ch 2 Cal Mode	2011	2	N/A	
Alarm ACK / Reset	12001	1	5	Write TRUE to ACK; resets to FALSE
Ch 1 D2A Raw	31001	4	N/A	10 bit value; 200 = 4mA, 1000 = 20mA
Ch 2 D2A Raw	31002	4	N/A	10 bit value; 200 = 4mA, 1000 = 20mA
Ch 1 A2D Raw	31003	4	N/A	10 bit value from A/D converter
Ch 2 A2D Raw	31004	4	N/A	10 bit value from A/D converter
Ch 1 Status	31005	4	N/A	See Channel Status Word definition
Ch 2 Status	31006	4	N/A	See Channel Status Word definition
Alarm Status Word	31007	4	N/A	See Alarm Status Word definition
Transmitter Status Word	31008	4	N/A	See Transmitter Status Word definition
Ch 1 Sensor Life	31009	4	N/A	16 bit signed integer ranging from -1 to 100 where -1 indicates Cal Required
Ch 2 Sensor Life	31010	4	N/A	16 bit signed integer ranging from -1 to 100 where -1 indicates Cal Required
Ch 1 Sensor Temp	31011	4	N/A	16 bit integer from 1 to 4095 scaled for -55°C to +125°C
Ch 2 Sensor Temp	31012	4	N/A	16 bit integer from 1 to 4095 scaled for -55°C to +125°C

Ch 1 Floating Point	33001	4	N/A	See Channel Floating Point definition
CH 2 Floating Point	33002	4	N/A	See Channel Floating Point definition
Ch 1 Measurement Name	40401 - 40408	3	N/A	16 ASCII characters (2 per register)
Ch 2 Measurement Name	40409 – 40416	3	N/A	16 ASCII characters (2 per register)
Ch 1 ASCII Reading	40417 – 40419	3	N/A	6 ASCII characters (2 per register)
Ch 2 ASCII Reading	40420 – 40422	3	N/A	6 ASCII characters (2 per register)
Ch 1 EUNITS	40423 – 40427	3	N/A	10 ASCII characters (2 per register)
Ch 2 EUNITS	40428 – 40432	3	N/A	10 ASCII characters (2 per register)
Ch 1 Preamp gain	40433	3	N/A	Contact factory
Ch 2 Preamp gain	40434	3	N/A	Contact factory
Firmware Version	40435 – 40436	3	N/A	4 ASCII characters (2 per register)
Ch 1 Cal Zero Real	41001	3	N/A	Real value without decimal point
Ch 1 Cal Zero Divisor	41002	3	N/A	Divisor = 1, 10, 100 or 1000
Ch 1 Cal Span Real	41003	3	N/A	
Ch 1 Cal Span Divisor	41004	3	N/A	
Ch 1 Zero Real	41005	3	N/A	
Ch 1 Zero Divisor	41006	3	N/A	
Ch 1 Span Real	41007	3	N/A	
Ch 1 Span Divisor	41008	3	N/A	
Ch 1 Fault Real	41009	3	N/A	
Ch 1 Fault Divisor	41010	3	N/A	
Ch 1 Alarm 1 Real	41011	3	N/A	
Ch 1 Alarm 1 Divisor	41012	3	N/A	
Ch 1 Alarm 2 Real	41013	3	N/A	
Ch 1 Alarm 2 Divisor	41014	3	N/A	
Ch 1 Alarm 3 Real	41015	3	N/A	
Ch 1 Alarm 3 Divisor	41016	3	N/A	
Ch 1 Man Gain Real	41017	3	N/A	
Ch 1 Man Gain Divisor	41018	3	N/A	
Ch 1 Man Offset Real	41019	3	N/A	
Ch 1 Man Offset Divisor	41020	3	N/A	
Ch 2 Cal Zero Real	41021	3	N/A	Real value without decimal point
Ch 2 Cal Zero Divisor	41022	3	N/A	Divisor = 1, 10, 100 or 1000
Ch 2 Cal Span Real	41023	3	N/A	
Ch 2 Cal Span Divisor	41024	3	N/A	

Ch 2 Zero Real	41025	3	N/A	
Ch 2 Zero Divisor	41026	3	N/A	
Ch 2 Span Real	41027	3	N/A	
Ch 2 Span Divisor	41028	3	N/A	
Ch 2 Fault Real	41029	3	N/A	
Ch 2 Fault Divisor	41030	3	N/A	
Ch 2 Alarm 1 Real	41031	3	N/A	
Ch 2 Alarm 1 Divisor	41032	3	N/A	
Ch 2 Alarm 2 Real	41033	3	N/A	
Ch 2 Alarm 2 Divisor	41034	3	N/A	
Ch 2 Alarm 3 Real	41035	3	N/A	
Ch 2 Alarm 3 Divisor	41036	3	N/A	
Ch 2 Man Gain Real	41037	3	N/A	
Ch 2 Man Gain Divisor	41038	3	N/A	
Ch 2 Man Offset Real	41039	3	N/A	
Ch 2 Man Offset Divisor	41040	3	N/A	
Ch 1 A2D MIN	41041	3	N/A	Min and max points for A/D and D/A
Ch 1 A2D MAX	41042	3	N/A	
Ch 1 D2A MIN	41043	3	N/A	
Ch 1 D2A MAX	41044	3	N/A	
Ch 2 A2D MIN	41045	3	N/A	
Ch 2 A2D MAX	41046	3	N/A	
Ch 2 D2A MIN	41047	3	N/A	
Ch 2 D2A MAX	41048	3	N/A	

**CHANNEL STATUS WORD BIT DEFINITION**

Channel Status Word	Bit 0	Alarm 1 Below (1), Alarm 1 Above (0)
	Bit 1	Alarm 2 Below (1), Alarm 2 Above (0)
	Bit 2	Alarm 3 Below (1), Alarm 3 Above (0)
	Bit 3	Alarm 1 Latch (1), Alarm 1 not latch (0)
	Bit 4	Alarm 2 Latch (1), Alarm 2 not latch (0)
	Bit 5	Alarm 3 Latch (1), Alarm 3 not latch (0)
	Bit 6	Alarm 3 Active (1), Alarm 3 fault only (0)
	Bit 7	Channel Disabled (1), Channel Enabled (0)
	Bit 8	Channel in Cal (1), Channel not in Cal (0)
	Bit 9	Channel Temp Compensation (1), no temp comp (0)
	Bit 10	Fault Relay Latch (1), no fault relay latch (0)
	Bit 11	Display (Track) Negative (1), no display negative (0)



	Bit 12	Transmit Sensor Life (1), no transmit sensor life (0)
	Bit 13-15	Reserved

**ALARM STATUS WORD BIT DEFINITION**

Alarm Status Word	Bit 0	Ch 1 Alarm 1 (1), no alarm (0)
	Bit 1	Ch 1 Alarm 2 (1), no alarm (0)
	Bit 2	Ch 1 Fault (1), no fault (0)
	Bit 3	Reserved
	Bit 4	Ch 2 Alarm 1 (1), no alarm (0)
	Bit 5	Ch 2 Alarm 2 (1), no alarm (0)
	Bit 6	Ch 2 Fault (1), no fault (0)
	Bit 7	Reserved
	Bit 8	Relay 1 Energized (1), no relay (0)
	Bit 9	Relay 2 Energized (1), no relay (0)
	Bit 10	Relay 3 Energized (1), no relay (0)
	Bit 11-15	Reserved

**TRANSMITTER STATUS WORD BIT DEFINITION**

Transmitter Status Word	Bit 0	Ch 1 Active (1), Ch 1 inactive (0)
	Bit 1	Ch 2 Active (1), Ch 2 inactive (0)
	Bit 2	Secure Level (1), no security (0)
	Bit 3	Marker Tx LED (1), no marker (0)
	Bit 4-11	Reserved
	Bit 12	Relay 1 Failsafe (1), normal (0)
	Bit 13	Relay 2 Failsafe (1), normal (0)
	Bit 14	Relay 2 Acknowledge (1), normal (0)
	Bit 15	Lock (1), not locked (0)

**CHANNEL FLOATING POINT DEFINITION**

Channel Floating Point	15 bit plus sign 2's complement with +/-5% over / under range applied. Contact GDS Corp for more information.
------------------------	--

## 10 TROUBLESHOOTING GUIDELINES

### TOXIC SENSOR INDICATES FAULT OR OVERRANGE

- Certain toxic sensors indicate off-scale low or high at power up and quickly drift towards zero. This is normal behavior.
- Toxic sensors showing constant FAULT: If local, remove sensor and examine for moisture or discoloration. Replace sensor if wet or discolored. If remote, check sensor cable and junction box for moisture or standing water. Remove sensor and examine for moisture or discoloration. FAULT indication generally indicates sensor useful life is exhausted.
- Toxic sensors left unpowered for more than 3 months are subject to accelerated degradation and may demonstrate a permanent loss of sensitivity.

### TOXIC SENSOR WILL NOT CALIBRATE

- Sensor reading during zero calibration exceeds upper limit of zero – sensor is defective and should be replaced.
- Sensor reading during span calibration too low – sensor may be defective. However, it may be possible to temporarily continue operation by increasing PREAMP GAIN. See Section 8.2 for more details.

### BRIDGE SENSOR INDICATES FAULT OR OVERRANGE

- Catalytic bead combustible sensors generally indicate off-scale high at power up and quickly drift towards zero as they reach operating temperature. This is normal behavior.
- Combustible sensors showing constant FAULT may have drifted below FAULT alarm level. Try readjusting SENSOR BALANCE to clear FAULT. If unsuccessful, replace sensor.
- Combustibles sensors showing constant OVERRANGE may have defective bead. If remote, check wiring for correct excitation voltage at sensor. Replace sensor.

### BRIDGE SENSOR WILL NOT CALIBRATE

- Sensor reading during zero calibration exceeds limits – readjust SENSOR BALANCE to reset zero if possible. If not, sensor is defective and should be replaced.
- Sensor reading during span calibration too low – sensor may be defective. However, it may be possible to temporarily continue operation by increasing PREAMP GAIN. See Section 8.2 for more details.

### RECEIVING DEVICE AND GASMAX DISPLAYED VALUES DON'T MATCH

- Check that zero and full scale range values match between GASMAX and receiving device (controller). Use DIAGNOSTICS menu to force GASMAX II output to 12mA (1/2 scale) and verify appropriate half-scale reading on controller.
- Check for high impedance shorts to ground on 4-20mA wiring.
- If 4-20mA output is off-scale low or high and cannot be adjusted using DIAGNOSTICS mode, IO/Power Supply board may be defective and should be replaced.

#### **CONTROLLER MODBUS DATA INCORRECT**

- Verify that MODBUS master is requesting data from correct registers (31001 for channel 1 (toxic), 31002 for channel 2 (combustible)).
- Verify that controller MIN and MAX count settings are correct. MIN counts should be “200” which corresponds to 4mA and MAX counts should be “1000” which corresponds to 20 mA.
- Verify that the GASMAX MODBUS address matches the address programmed into the controller’s channel configuration.

#### **CONTROLLER SHOWING MODBUS COMM ERROR**

- Check for incorrect MODBUS polarity (swap “A” and “B” if unsure; no damage will occur).
- Verify that MODBUS master is requesting data from correct MODBUS address.
- Verify that MODBUS master is requesting correct registers: 31001 for channel 1 (toxic), 31002 for channel 2 (combustible).
- Verify that there are no other MODBUS slave devices with identical MODBUS address.

#### **GASMAX DISPLAY BLANK**

- Verify DC power at IO/Power Supply board, TB2, terminals 1 (+24) and 4 (Gnd).
- Verify ribbon cable connected between IO/Power Supply board and Display Assembly.
- Verify that there are **no** wires connected to the 4-20mA LOOP INPUT on the back of the Display Assembly.

#### **GASMAX ERROR CODES**

- 01 – Incorrect sensor type – new sensor does not match most recent type of sensor. This is normal if changing sensor types. If unexpected, verify that new sensor type matches previous sensor type.
- 02 – Zero or span mismatch. Smart sensor zero or span values differ from those stored in the GASMAX.
- 03 – Sensor Calibration Error – Contact factory.

- 04 – Zero calibration failure – Zero readings must be within 10% of zero. For example, if the range is 0-100 ppm, the zero reading cannot be above 10 ppm. For bridge-type sensors, it may be possible to readjust the balance to restore a zero reading. Toxic sensors with high zero readings must be replaced.
- 05 – Span calibration failure – Span readings must be within a range of from ½ to 2x the target value. For example, if the target is 50 ppm, the sensor must output at least 25 ppm and no higher than 100 ppm at the current preamp gain setting for calibration to proceed.
- 06 – History data file full. Clear event log to remove.
- 07 – Sensor Channel Data CRC Fail – Error in sensor data transfer. Contact factory.
- 08 – System Data CRC Fail – Error in system data file. Contact factory.
- 09 – Custom Data CRC Fail – Error in system data file. Contact factory.
- 10- Linearization Data CRC Fail – Error in system data file. Contact factory.

### **SOFTWARE RESET (“COLD BOOT”)**

If the GASMAX display shows ‘nonsense’ characters or one or more of the settings appear to be corrupted, performing a “Cold Boot” will restore the default values in the non-volatile memory and may clear the problem. To perform a ‘Cold Boot”, perform one of the two following procedures:

- Disconnect power. Hold a magnetic wand over the EDIT key and apply 24VDC power. Hold the magnet until the screen shows a “COLD BOOT” message.
- Hold the magnetic wand over the NEXT key until the “Enter code sequence’ appears. Press four “UP” keys to enter the XMITTER menu. Make a change in any value and then restore the value to its original setting. Press the NEXT key to exit and THEN IMMEDIATELY PLACE THE MAGNETIC WAND OVER THE EDIT KEY. Hold the magnet until the screen shows a “COLD BOOT” message.

Note that a COLD BOOT will reset certain values to their default setting, including the MODBUS address value. If a Smart Sensor is connected to a local sensor head, the GASMAX will reload the sensor type, range, cal span value and other sensor –related values automatically.

## 11 SPARE PARTS

### DISPLAY AND ENCLOSURE

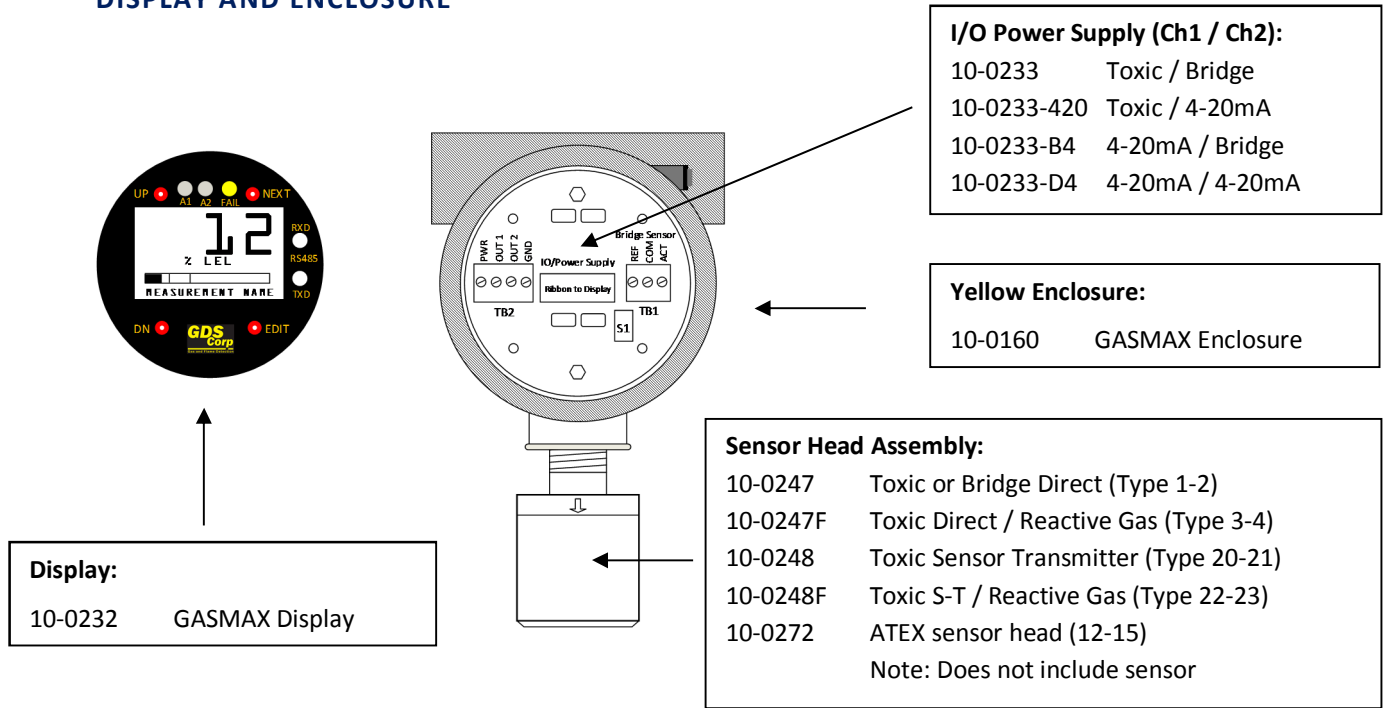

Figure 11-1: GASMAX II + Local Sensor Spare Parts

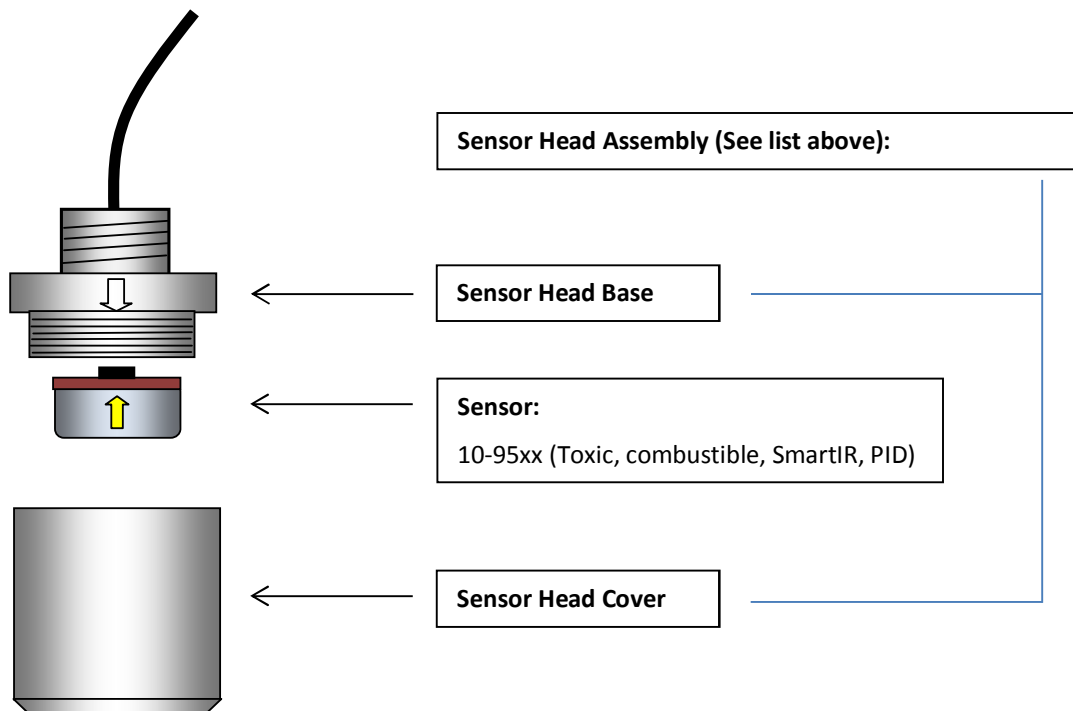
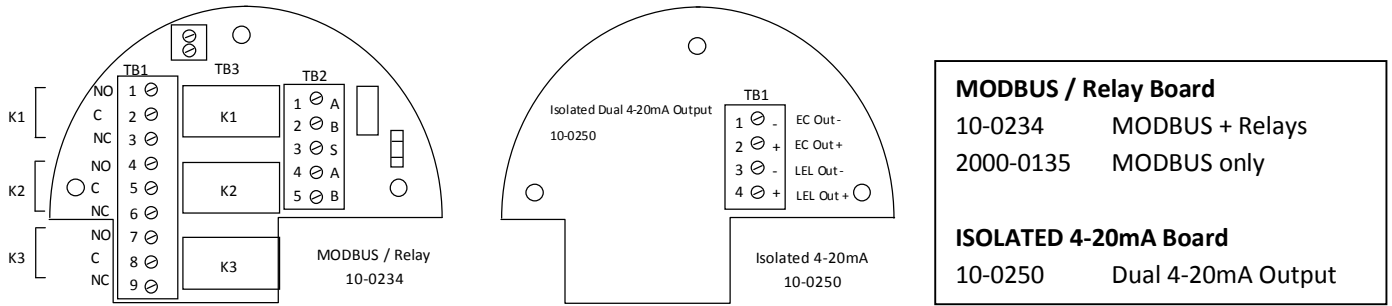

Figure 11-2: GASMAX Sensor Head

**EXPANSION BOARDS**



**Figure 11-3: GASMAX Expansion Boards**

**SENSOR HEAD ACCESSORIES**

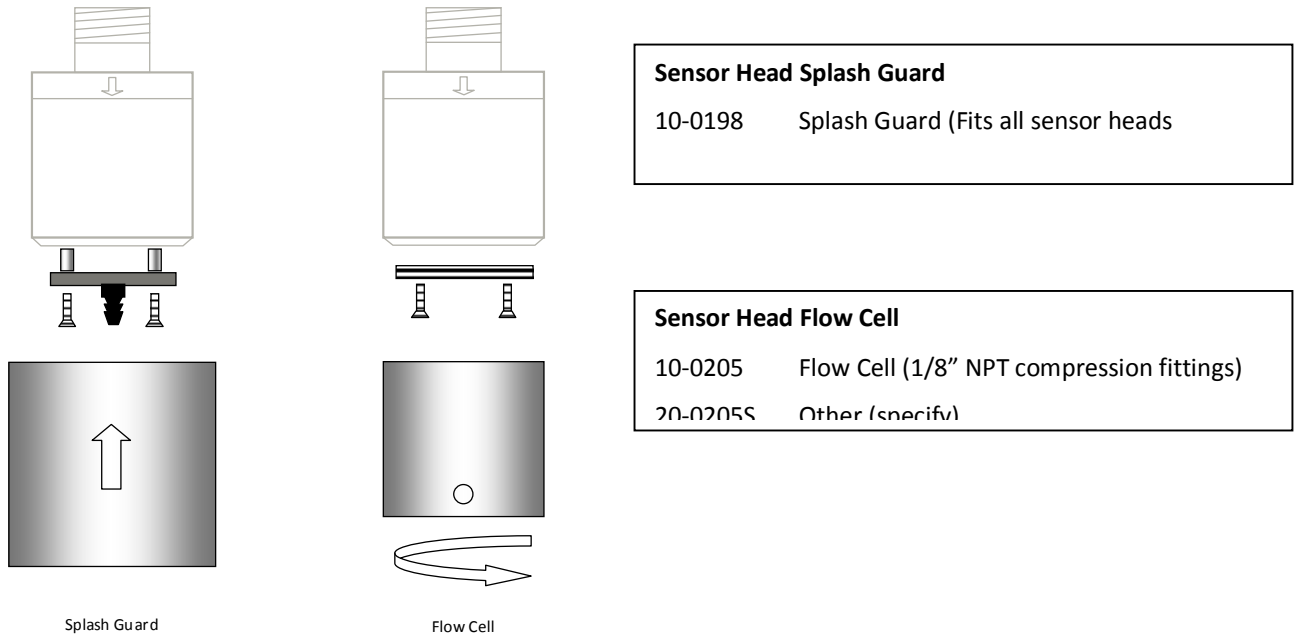

**Figure 11-4: GASMAX Sensor Head Splash Guard & Flow Cell**

## REMOTE DIRECT SENSOR

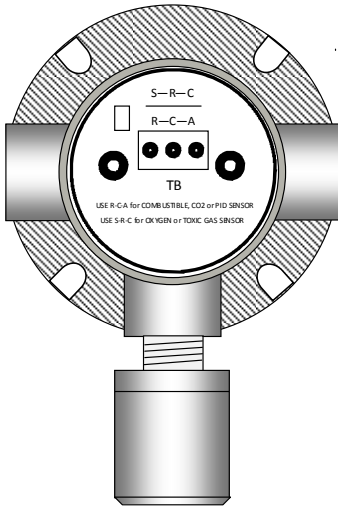

### Remote Sensor Head Assembly:

20-0126 Remote Toxic or Bridge Direct (Type 5-6)

20-0127 Remote Toxic / Reactive Gas (Type 7-8)

Note: Does not include sensor

Figure 11-5: GASMAX II Remote Direct Sensor Head

## REMOTE SENSOR TRANSMITTER

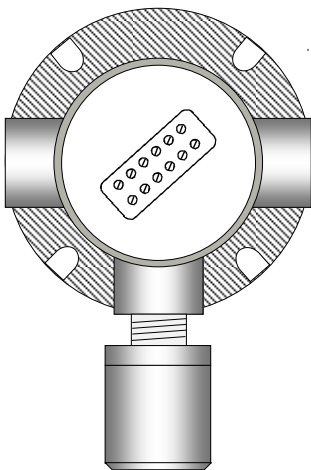

### Remote Sensor Transmitter Head Assembly:

20-0129 Remote Toxic Sensor Transmitter (Type 24-25)

20-0130 Remote Toxic S-T / Reactive Gas (Type 26-27)

Note: Does not include sensor

Figure 11-6: GASMAX II Remote Sensor Transmitter

## DUAL LOCAL SENSORS

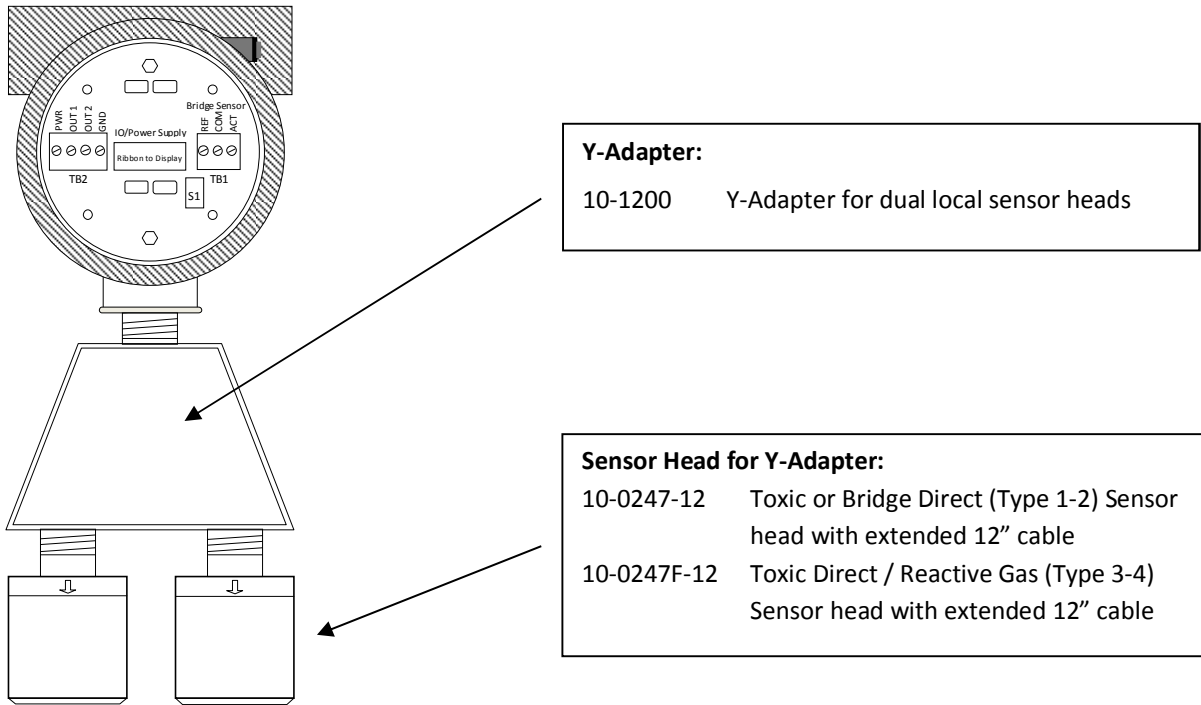

Figure 11-7: GASMAX II Dual with Y-Adapter



## 12 DRAWINGS AND DIMENSIONS

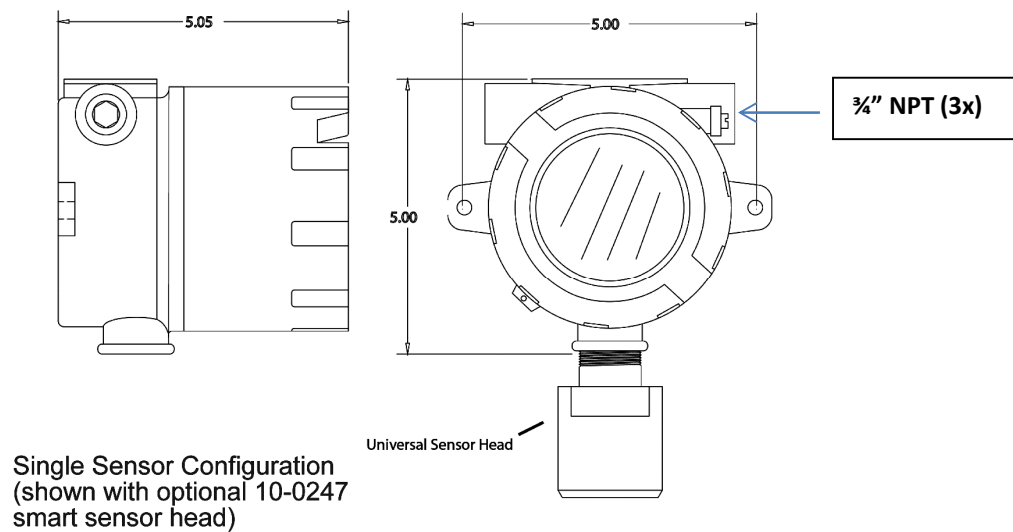

Figure 12-1: GASMAX Local Sensor Dimensions

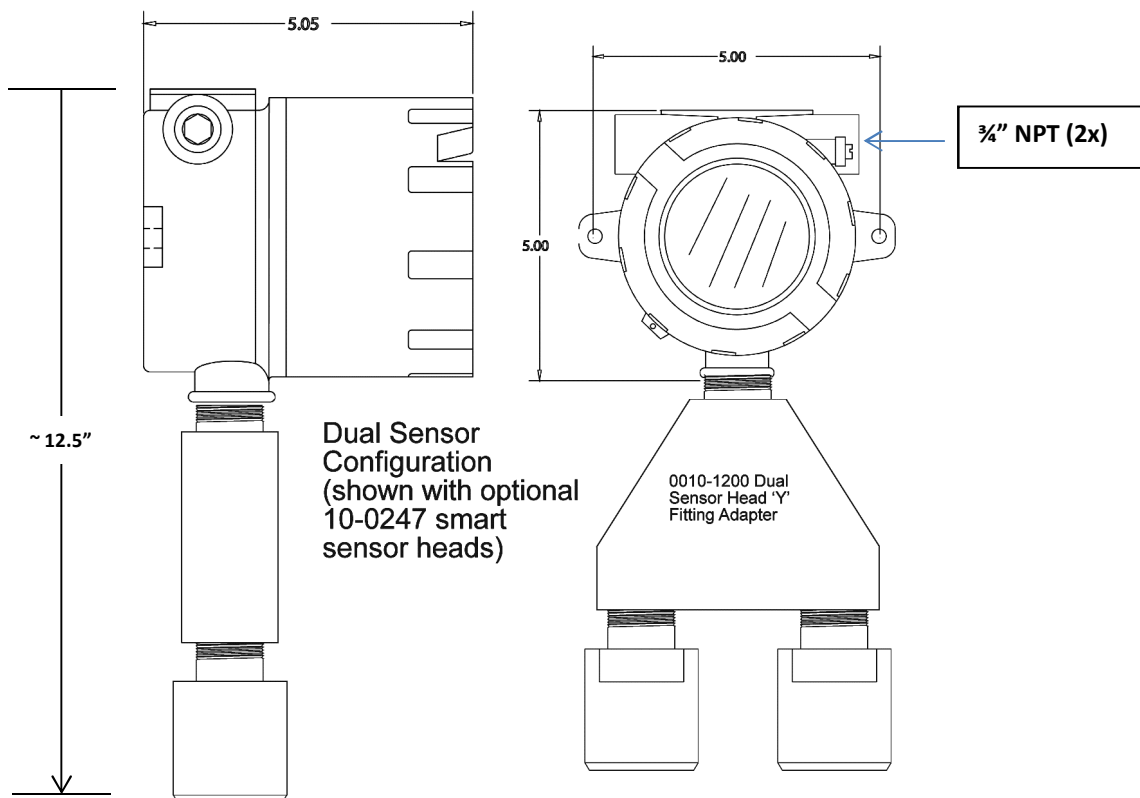

Figure 12-2: GASMAX Dual Local Sensor Dimensions