



Gas and Flame Detection

Operation and Maintenance Manual

GASMAX CX Single / Dual Channel Gas Monitor

GDS Corp.
2513 Hwy 646 • Santa Fe, Texas 77510
409-927-2980 • 409-927-4180 (Fax) • www.gdscorp.com

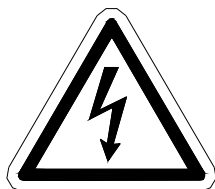

CAUTION: FOR SAFETY REASONS THIS EQUIPMENT MUST BE OPERATED AND SERVICED BY QUALIFIED PERSONNEL ONLY. READ AND UNDERSTAND INSTRUCTION MANUAL COMPLETELY BEFORE OPERATING OR SERVICING.

ATTENTION: POUR DES RAISONS DE SÉCURITÉ, CET ÉQUIPEMENT DOIT ÊTRE UTILISÉ, ENTRETENU ET RÉPARÉ UNIQUEMENT PAR UN PERSONNEL QUALIFIÉ. ÉTUDIER LE MANUE D'INSTRUCTIONS EN ENTIER AVANT D'UTILISER, D'ENTREtenir OU DE RÉPARER L'ÉQUIPEMENT.

REVISION HISTORY

Revision 1.0 4/15/14 Initial Release

CONTENTS

1	SAFETY INFORMATION	7
2	OVERVIEW	8
3	HARDWARE	9
4	INSTALLATION	10
	Selecting a Location	10
	Explosion Proof Installation	10
	Intrinsically Safe Installation	10
	Mounting the GASMAX CX Instrument Enclosure	10
	Connecting DC Power & Output Signal Wiring	11
	Connecting to an Ethernet Network	12
	Optional Relay / MODBUS Interface	12
	Optional MODBUS Junction Box	13
	Local Smart Toxic sensor	15
	Connecting a Remote Toxic Sensor transmitter	16
	Local Smart Bridge Sensor	17
	Connecting a Remote INFRARED Sensor transmitter	18
	Local GDS-IR Infrared Sensor	19
	Connecting a Remote GDS-IR Infrared Sensor	20
	Connecting an External 4-20mA Input Device	21
5	SETUP AND OPERATION	22
	GASMAX Controls and Display	22
	Display Screens	23
	Initial Setup	24

Normal Operating Mode	24
Alarm Operation – ALARM 1, 2 and 3	24
Alarm Operation – FAULT	25
6 CALIBRATION	26
Calibration Overview	26
Calibration Procedure	27
7 MAINTENANCE	29
Normal Maintenance	29
Sensor Replacement – Local Sensors	29
Sensor Replacement – Remote Sensors	30
8 TROUBLESHOOTING	32
Toxic Sensor Indicates Fault or Overrange	32
Toxic Sensor Will Not Calibrate	32
Bridge Sensor Indicates Fault or Overrange	32
Bridge Sensor Will Not Calibrate	32
Receiving Device and GASMAX Displayed Values Don't Match	33
Controller MODBUS Data Incorrect	33
Controller Showing MODBUS COMM ERROR	33
GASMAX Display Blank	33
Software reset ("Cold Boot")	33
9 SPECIFICATIONS	34
10 USER MENUS	35
Alarm Outputs Menu	36
Channel Settings Menu	37

Comm Settings Menu	39
System Settings Menu	40
Diagnostics Menu	41
11 NETWORK INTERFACE	42
MODBUS Registers	42
12 SPARE PARTS	50
Sensor Head Accessories	51
13 DRAWINGS AND DIMENSIONS	52

TABLE OF FIGURES

FIGURE 3-1 GASMAX CX GAS MONITOR 9

FIGURE 4-1: GASMAX CX I/O POWER & SIGNAL WIRING..... 11

FIGURE 4-2 ETHERNET INTERFACE 12

FIGURE 4-3 GASMAX CX OPTIONAL RELAY / MODBUS INTERFACE 12

FIGURE 4-4: MODBUS WIRING JUNCTION BOX..... 13

FIGURE 4-5: MODBUS JBOX LOCATION OPTIONS..... 14

FIGURE 4-6: LOCAL SMART TOXIC SENSOR CONNECTION 15

FIGURE 4-7: REMOTE TOXIC SENSOR TRANSMITTER CONNECTION..... 16

FIGURE 4-8: LOCAL SMART BRIDGE SENSOR CONNECTION..... 17

FIGURE 4-9 REMOTE INFRARED SENSOR TRANSMITTER 18

FIGURE 4-10: LOCAL GDS-IR INFRARED SENSOR 19

FIGURE 4-11: REMOTE GDS-IR CONNECTION..... 20

FIGURE 4-12: REMOTE 4-20MA INPUT 21

FIGURE 5-1: GASMAX CX DISPLAY SCREEN SEQUENCE..... 22

FIGURE 5-2 GASMAX DATA DISPLAY..... 23

FIGURE 5-3 GASMAX TREND DISPLAY..... 23

FIGURE 6-1: CALIBRATION FLOWCHART 28

FIGURE 7-1: GASMAX SENSOR REPLACEMENT..... 30

FIGURE 10-1: MAIN MENU TREE 35

FIGURE 10-2: ALARM OUTPUTS MENU TREE 36

FIGURE 10-3: CHANNEL SETTINGS MENU TREE (1) 37

FIGURE 10-4: CHANNEL SETTINGS MENU TREE (2) 38

FIGURE 10-5: COMM SETTINGS MENU 39

FIGURE 10-6: SYSTEM SETTINGS MENU TREE 40

FIGURE 10-7: DIAGNOSTICS MENU TREE 41

FIGURE 12-1: GASMAX CX + LOCAL SENSOR SPARE PARTS..... 50

FIGURE 12-2: GASMAX SENSOR HEAD..... 51

FIGURE 12-4: GASMAX SENSOR HEAD SPLASH GUARD & FLOW CELL..... 51

FIGURE 13-1 GASMAX CX DIMENSIONS..... 52

FIGURE 13-2 GASMAX CX REMOTE SENSOR TRANSMITTER DIMENSIONS 53

1 SAFETY INFORMATION

Important – Read Before Installation

Users should have a detailed understanding of GASMAX CX operating and maintenance instructions. Use the GASMAX CX only as specified in this manual or detection of gases and the resulting protection provided may be impaired. Read the following WARNINGS prior to use.

WARNINGS

- The GASMAX CX gas monitor described in this manual must be installed, operated and maintained in accordance with information contained herein. Installation in any hazardous area must comply with all applicable restrictions, requirements and guidelines for said hazardous areas. It is the end user customer's final decision to ensure that the GASMAX CX is suitable for the intended use.
- The GASMAX CX is designed and constructed to measure the level of certain gases in ambient air. Accuracy in atmospheres containing steam or inert gases cannot be guaranteed.
- Always mount the sensor head vertically with the sensor head facing down. However, the GDS-IR infrared sensor may be mounted vertically or horizontally.
- Do not paint transmitter or sensor assembly.
- Do not operate the GASMAX CX if its enclosure is damaged or cracked or has missing components. Make sure the cover, internal PCB's and field wiring are securely in place before applying power.
- Do not expose the GASMAX CX to electrical shock or continuous severe mechanical shock. Protect the GASMAX CX and related sensor assemblies from dripping liquids and high power sprays.
- Calibrate with known target gas at start-up and check on a regular schedule, at least every 90 days. More frequent inspections are encouraged to spot problems such as dirt, oil, paint, grease or other foreign materials on the sensor head.
- Periodically test for correct operation of the system's alarm events by exposing the monitor to a targeted gas concentration above the High Alarm set point.
- Use only for applications described within this manual.

2 OVERVIEW

The GASMAX CX is a single or dual channel fixed-point gas monitor designed to provide continuous monitoring of toxic or combustible gases in hazardous areas. Gas values are displayed in calibrated engineering units as well as bar graph or 30-minute trend graph format.

The GASMAX CX supports one or two local or remote mount sensors for toxic or combustible gases. The advanced microcontroller, non-intrusive magnetic interface and superior full color graphic LCD interface offers rapid setup, simplified operation and enhanced diagnostics not found in previous generation products. On-board non-volatile memory retains all configuration data during power interruptions. Two independent 4-20 mA outputs allow for easy connection to control systems or other alarm

instrumentation, and a built-in Ethernet port allows the GASMAX CX to be easily integrated into a facilities network. Additional output options include 4x alarm relays and dual channel MODBUS slave interfaces.

Built-in user-prompted calibration makes it easy for one person to perform calibration and maintenance without opening the enclosure or declassifying the area. A battery-powered real-time clock and event log allows the GASMAX CX to track calibration and alarm events for later recall on the LCD readout.

For toxic gases the GASMAX CX supports a wide range of electrochemical (“echem”) sensors. These sensors use chemical reactions to sense the presence of gases such as hydrogen sulfide, chlorine, sulfur dioxide and many others. Unlike previous generation gas detectors, GASMAX CX sensors contain all the necessary micro-electronics needed to convert the extremely low level sensor output signals into digital values that are immune to interference and noise. When combined with state-of-the-art digital signal processing and filtering, the GASMAX is capable of gas detecting levels lower than ever before.

For combustible gases the GASMAX CX offers three different choices. In addition to traditional catalytic bead (“cat bead”) sensor, the GASMAX CX supports the GDS Corp SmartIR infrared sensor and GDS-IR infrared sensor as well as the latest generation photoionization detector (PID) sensors for measurement of volatile organic compounds such as benzene or toluene.

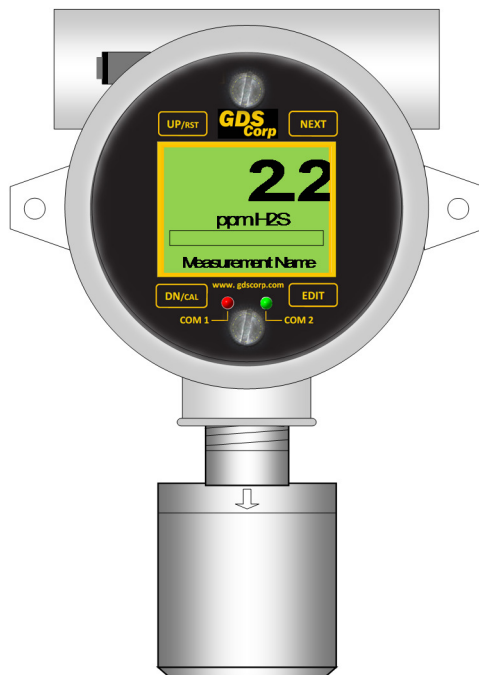

3 HARDWARE

The GASMAX CX is enclosed in a CSA / FM / IECEx certified anodized aluminum explosion proof yellow enclosure designed to protect the electronics and make it easy for workers to identify in industrial environments. The screw-on front cover is easily removed for installation and maintenance; however, built-in user interface magnetic switches allow operators and technicians to adjust, calibrate or troubleshoot the GASMAX CX without declassifying the area.

Local sensors are contained in a stainless steel sensor head, typically attached to the bottom of the GASMAX CX as shown below. The normal sensor head includes an integrated stainless steel flame arrestor that must be removed for the detection of certain reactive gases such as chlorine or chlorine dioxide. If removed, the GASMAX CX is not certified for use in hazardous areas.

See Chapter 13 for drawings and dimensions.

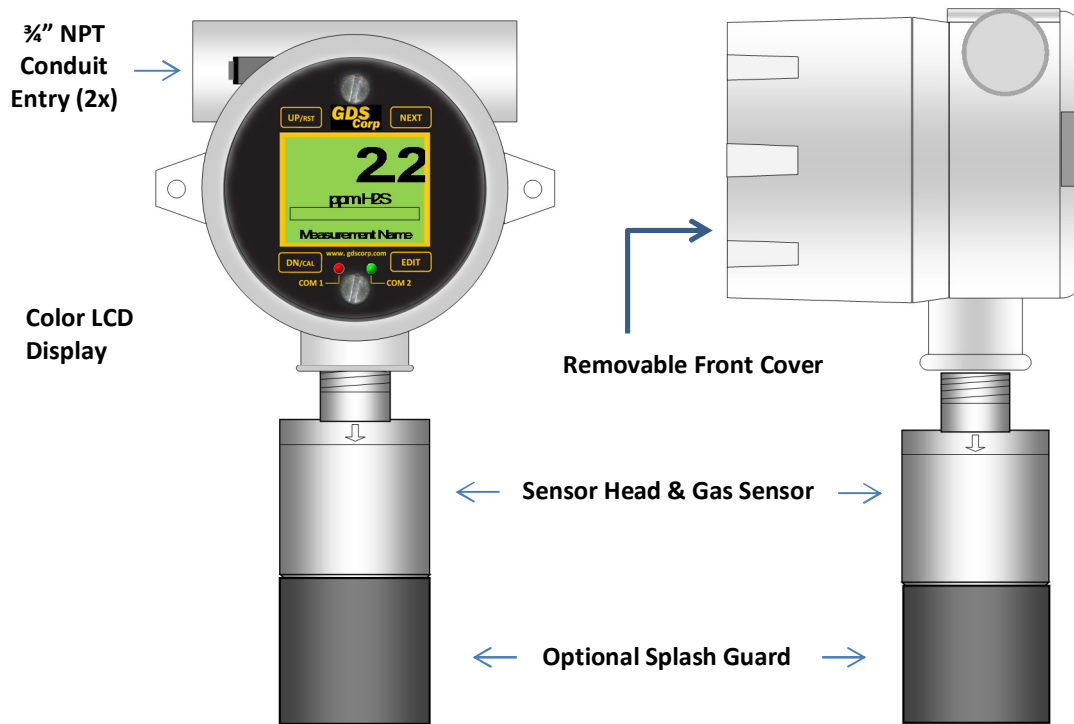

Figure 3-1 GASMAX CX GAS MONITOR

4 INSTALLATION

SELECTING A LOCATION

Factors such as prevailing winds, target gas density, potential leak sources, air movement machinery and similar environmental variables are important when selecting a location for the GASMAX CX gas monitor or gas sensor. Even though the GASMAX CX is designed for rugged service, sensors and electronics should be protected from environmental damage due to water, snow, shock, vibration and dirt. In addition, the sensor and / or display should be located such that regular maintenance and periodic sensor replacement can be readily accomplished. While there are no industry standards for gas detector placement, professional tools exist that can simulate leaks or spills and provide excellent guidance for locating gas detectors throughout a facility.

EXPLOSION PROOF INSTALLATION

GASMAX CX monitors with standard explosion-proof sensor heads are certified for use in Class 1 Division 1 hazardous areas. Installation in these areas should follow best industry standard practices and all appropriate electrical codes. Generally, these codes require rigid metal conduit, poured seals and other installation elements necessary to ensure safety. In all cases, GDS Corp recommends any GASMAX sensor be mounted vertically with the sensor opening facing down. If there is a possibility that water or other liquid may be present, GDS Corp further recommends the installation of a sensor head Splash Guard (p/n 10-0205) to protect the sensor from damage. For maximum protection against RF interference or electrical surge, the GASMAX CX enclosure, all remote sensors and interconnecting conduit must be properly grounded.

INTRINSICALLY SAFE INSTALLATION

The GASMAX CX is not certified for use as an Intrinsically Safe device.

MOUNTING THE GASMAX CX INSTRUMENT ENCLOSURE

The GASMAX CX standard enclosure is a cast aluminum explosion-proof (NEMA 7) enclosure as shown in Figure 4-1. Two channel GASMAX CX units with dual local sensor heads include a “Y” adapter, shown in Figure 4-2.

The GASMAX CX or remote sensor should always be mounted with the sensor head opening facing down. If necessary, a Splash Guard (p/n 10-0205) should be attached if there is any chance that water or liquid spray could enter the sensor opening from below. Be sure to leave sufficient room (~ 12”) below the sensor head to allow for ambient air circulation and easy access for attachment of a Calibration Cup and / or removal of the sensor head cover for sensor replacement.

CONNECTING DC POWER & OUTPUT SIGNAL WIRING

To access the GASMAX signal and power connections, remove the cover on the GASMAX CX explosion-proof enclosure, loosen the 2 thumbscrews holding the display assembly and remove it. The display will remain connected to the IO/Power Supply PCB mounted in the back of the enclosure by a short ribbon cable. Route the power and signal wires through the conduit entry and connect to terminal block "TB1". Plus 24VDC connects to TB1-1. DC Ground connects to TB1-4. Channel One 4-20mA output is available on TB1-2 and Channel Two 4-20mA output is available on TB1-3. **GDS Corp always recommends using shielded wire for signal and power cable.**

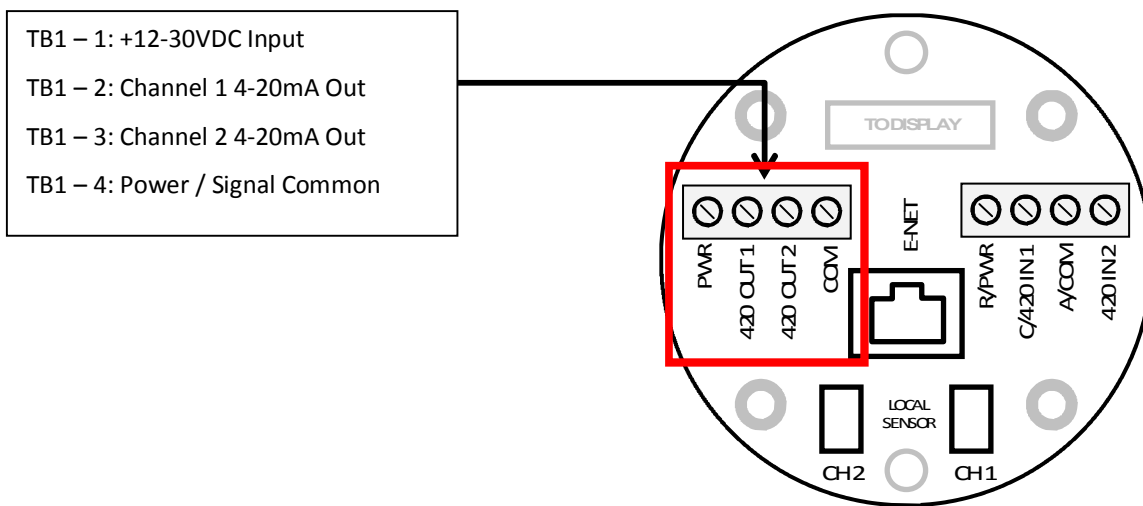

Figure 4-1: GASMAX CX I/O Power & Signal Wiring

NOTE: THE MAXIMUM DISTANCE 4-20 MA SIGNALS CAN TRAVEL IS DEPENDENT UPON CABLE GAUGE, DC POWER SUPPLY VOLTAGE LEVEL AND INPUT IMPEDANCE OF THE RECEIVING DEVICE. ASSUMING A NOMINAL 24 VDC POWER SUPPLY, 100 OHM LOAD AND MAXIMUM TOTAL LOOP RESISTANCE OF 750 OHMS:

#18GA, 0.0064 OHM/FT => 9.6 MILES / 15.5 KM

#24GA, 0.026 OHMS/FT => 2.3 MILES / 3.7 KM

CONNECTING TO AN ETHERNET NETWORK

The GASMAX CX provides a standard 10/100 Ethernet network interface on the Power I/O board as shown in Fig. 4-2. Both DHCP and fixed IP address modes are provided. The Ethernet interface provides access to the MODBUS database via MODBUS/TCP as well as remote access and setup via a built-in web server.

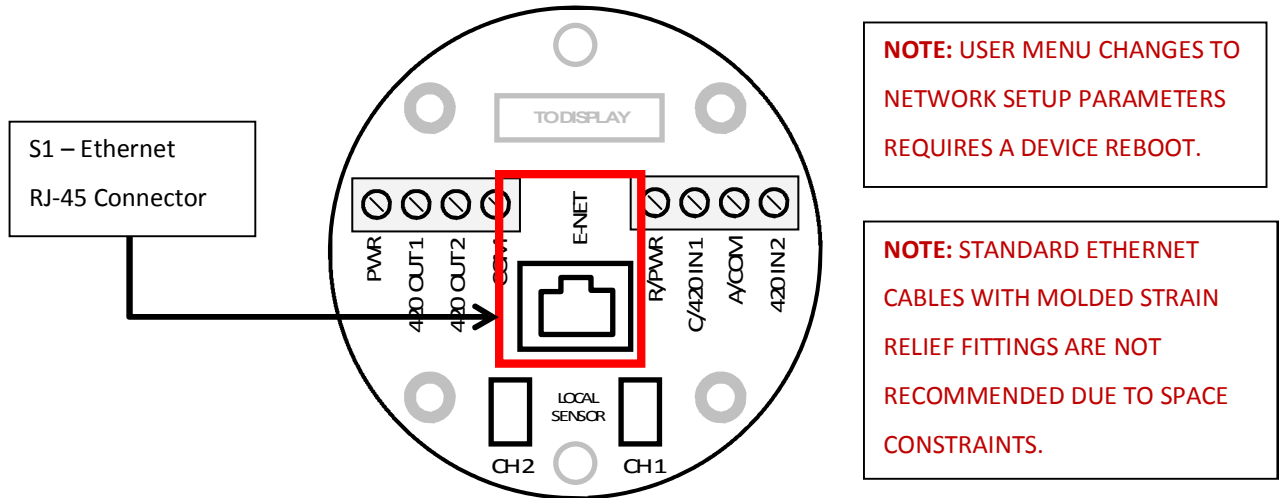

Figure 4-2 Ethernet Interface

OPTIONAL RELAY / MODBUS INTERFACE

The optional Relay / Modbus board is connected “piggyback” to the back of the GASMAX CX Display Assembly and provides three level alarm relays, a FAULT relay (“K3”), two RS-485 Modbus RTU serial ports and access to the Digital Input / Remote ACK port.

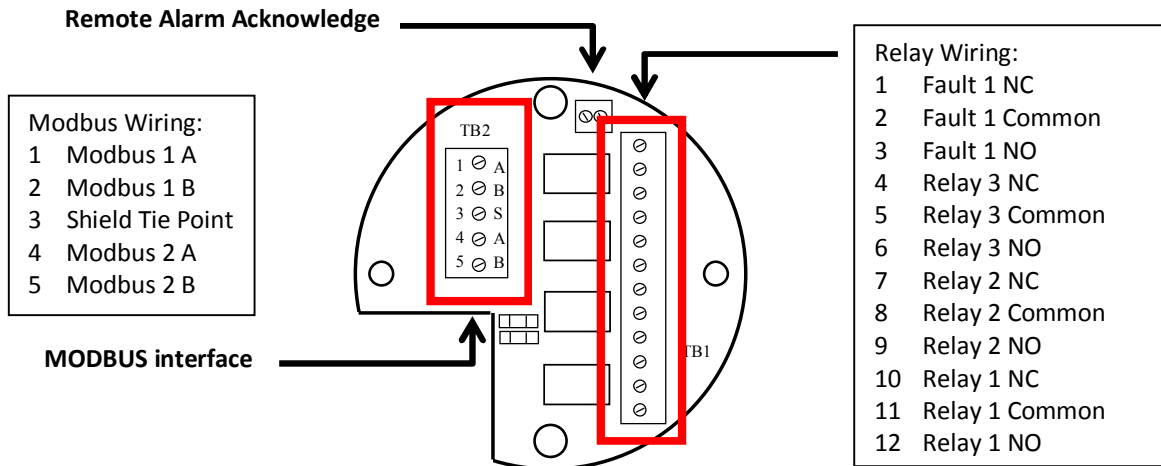

Figure 4-3 GASMAX CX Optional Relay / MODBUS Interface

OPTIONAL MODBUS JUNCTION BOX

MODBUS system architecture requires that the devices in any MODBUS loop be connected in a daisy-chain layout. This minimizes signal reflections and improves signal noise margin. A MODBUS Termination Jumper installs a load resistor across the MODBUS signal lines and should only be set to “A” (ON) at the last device in the string.

Cable selection for MODBUS systems is important for both signal integrity and power distribution. MODBUS / RS-485 transmissions use low-voltage differential signaling to achieve reasonable data rates over very long distances, up to 4000 feet without a repeater.

For MODBUS data signals, GDS Corp recommends 20GA to 24GA twisted shielded cable. Daisy-chain power distribution may require larger gauge wire since it is critical that the supply voltage for the GASMAX CX at the far end of the string not fall below 12VDC during power-up.

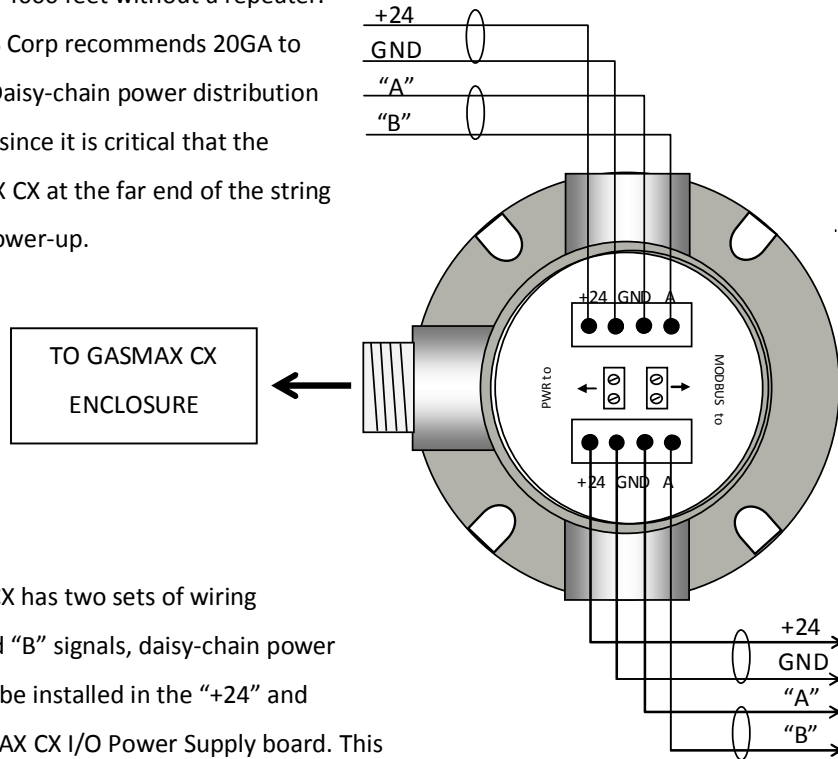

Note that while the GASMAX CX has two sets of wiring terminals for MODBUS “A” and “B” signals, daisy-chain power wiring requires that two wires be installed in the “+24” and “GND” terminals on the GASMAX CX I/O Power Supply board. This can be difficult if wire sizes are larger than #18GA. For these reasons, if MODBUS is required GDS Corp recommends the addition of the MODBUS Wiring Junction Box (see Fig. 5-7). This option minimizes the need to access wiring inside the GASMAX CX, provides individual wire landing points for incoming and outgoing MODBUS and power wiring and shields, and makes it easy to temporarily disconnect the GASMAX CX power or MODBUS connections without affecting any other MODBUS device.

Figure 4-4: MODBUS Wiring Junction Box

The MODBUS wiring junction box is attached to the GASMAX CX, either on the bottom fitting or one of the side fittings, depending on installation requirements. Specify BOTTOM, LSIDE or RSIDE when ordering (See Fig. 4-5).

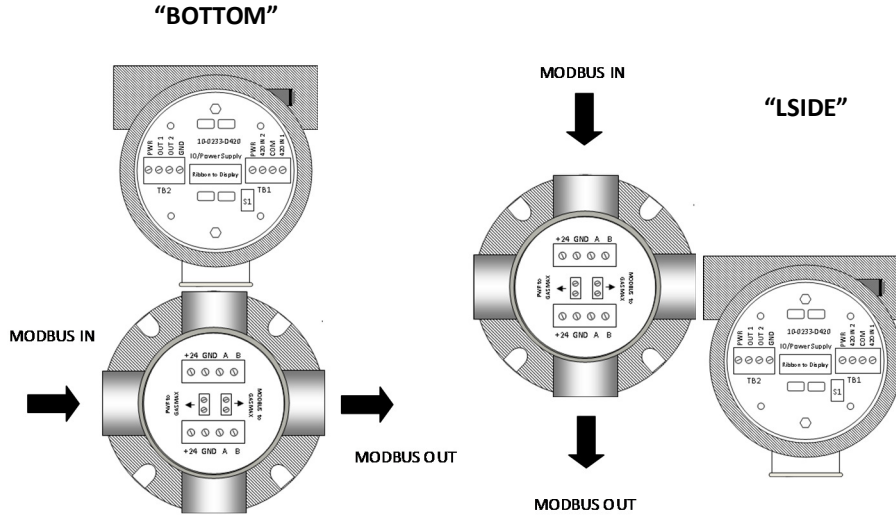

Figure 4-5: MODBUS JBOX LOCATION OPTIONS

LOCAL SMART TOXIC SENSOR

Local Smart toxic sensors are factory installed in a sensor head directly attached to the GASMAX CX enclosure. Local Smart toxic sensors and can be connected to either Channel 1 or Channel 2 sensor inputs on the I/O Power Supply board as shown below.

Smart sensors are automatically recognized on power-up and upload range, calibration and production date information to the GASMAX for use during operation and setup.

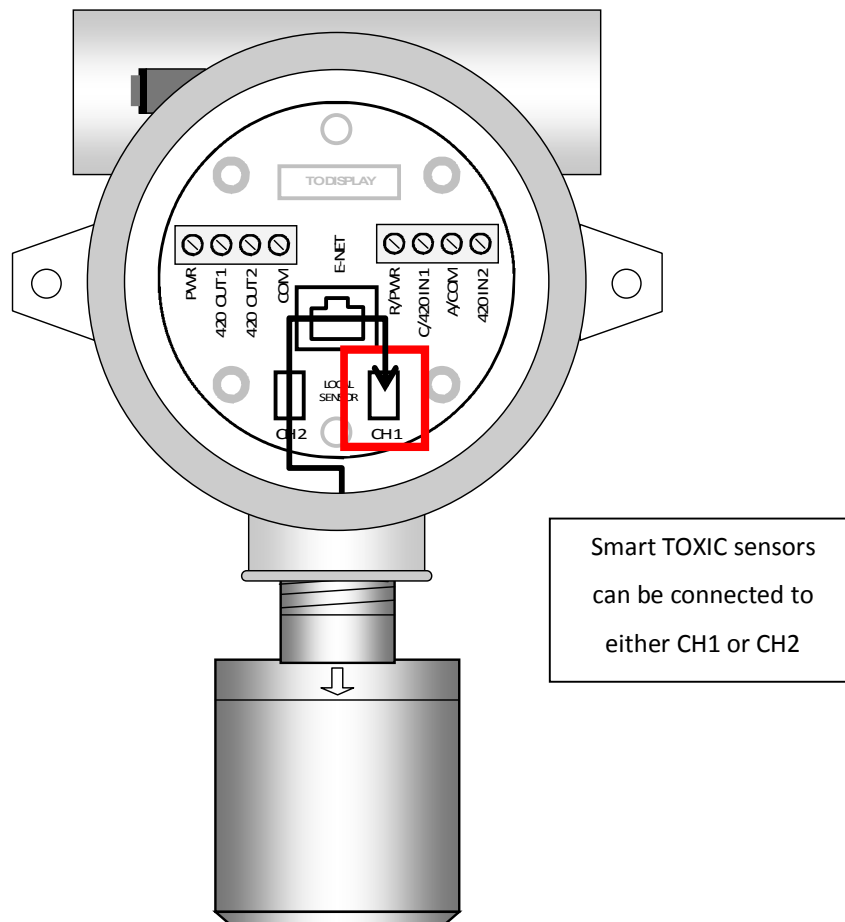

Figure 4-6: Local Smart Toxic Sensor Connection

IMPORTANT: TOXIC SENSORS ARE SUBJECT TO ACCELERATED DETERIORATION IF POWER IS NOT SUPPLIED WITHIN 3 MONTHS OF SHIPMENT FROM GDS CORP.

CONNECTING A REMOTE TOXIC SENSOR TRANSMITTER

GASMAX CX monitors with remote-mount toxic sensor transmitters are shipped in two pieces and sensor wiring must be installed by the end user. Remote toxic sensor transmitters connect to the Channel 1 or Channel 2 4-20mA analog input connections on the Power I/O board as shown below.

Remote toxic sensor transmitters use industry standard 4-20mA signal levels and can therefore be mounted at some distance from the GASMAX CX. GDS Corp recommends a maximum distance of 500 ft. / 150 m using shielded two-wire cable sized appropriately.

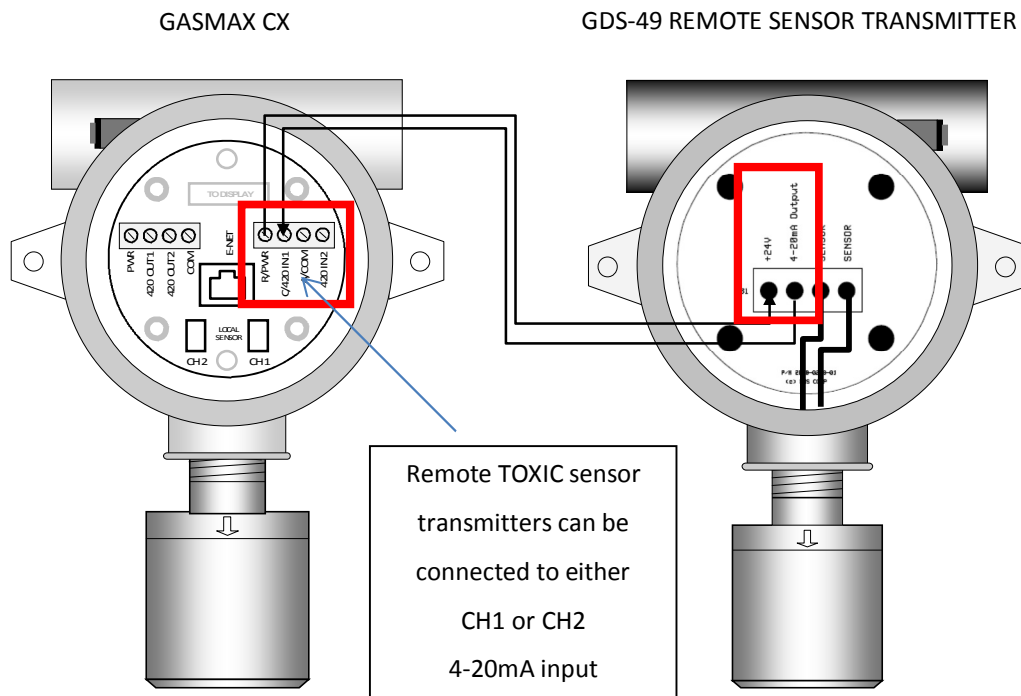

Figure 4-7: Remote Toxic Sensor Transmitter Connection

NOTE: FIELD WIRING FOR REMOTE TOXIC SENSOR TRANSMITTERS IS NOT POLARIZED AND MAY BE CONNECTED IN ANY ORDER.

IMPORTANT: TOXIC SENSORS ARE SUBJECT TO ACCELERATED DETERIORATION IF POWER IS NOT SUPPLIED WITHIN 3 MONTHS OF SHIPMENT FROM GDS CORP.

LOCAL SMART BRIDGE SENSOR

Local bridge-type sensors, including catalytic bead, SmartIR infrared sensors for combustibles and CO2 and photoionization detectors (PID) for volatile organic compounds are factory installed and must be connected to the CH 1 Smart Sensor connector as shown below.

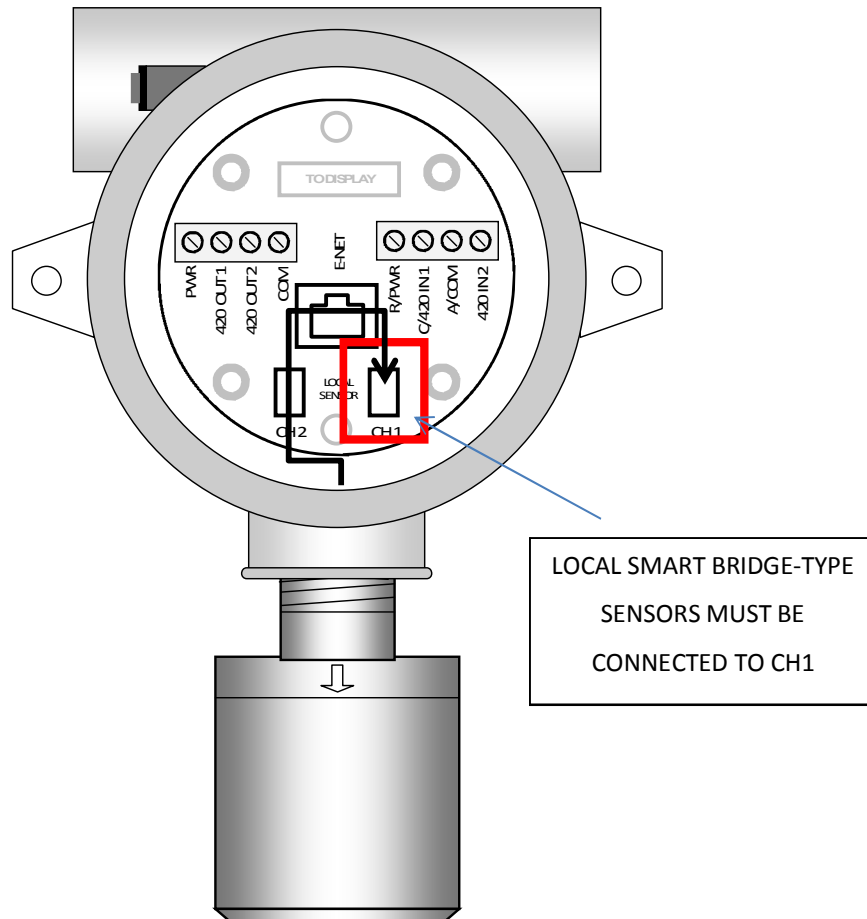

Figure 4-8: Local Smart Bridge Sensor Connection

NOTE: LOCAL SMART BRIDGE SENSORS AUTOMATICALLY ADJUST SENSOR EXCITATION VOLTAGE.

CONNECTING A REMOTE INFRARED SENSOR TRANSMITTER

GASMAX CX monitors with remote-mount infrared sensor transmitter for combustibles or CO₂ are shipped in two pieces and sensor wiring must be installed by the end user. Remote infrared sensor transmitters connect to the Channel 1 or Channel 2 4-20mA analog input connections on the Power I/O board as shown below.

Remote infrared sensor transmitters use industry standard 4-20mA signal levels and can therefore be mounted at some distance from the GASMAX CX. GDS Corp recommends a maximum distance of 500 ft. / 150 m using shielded two-wire cable sized appropriately.

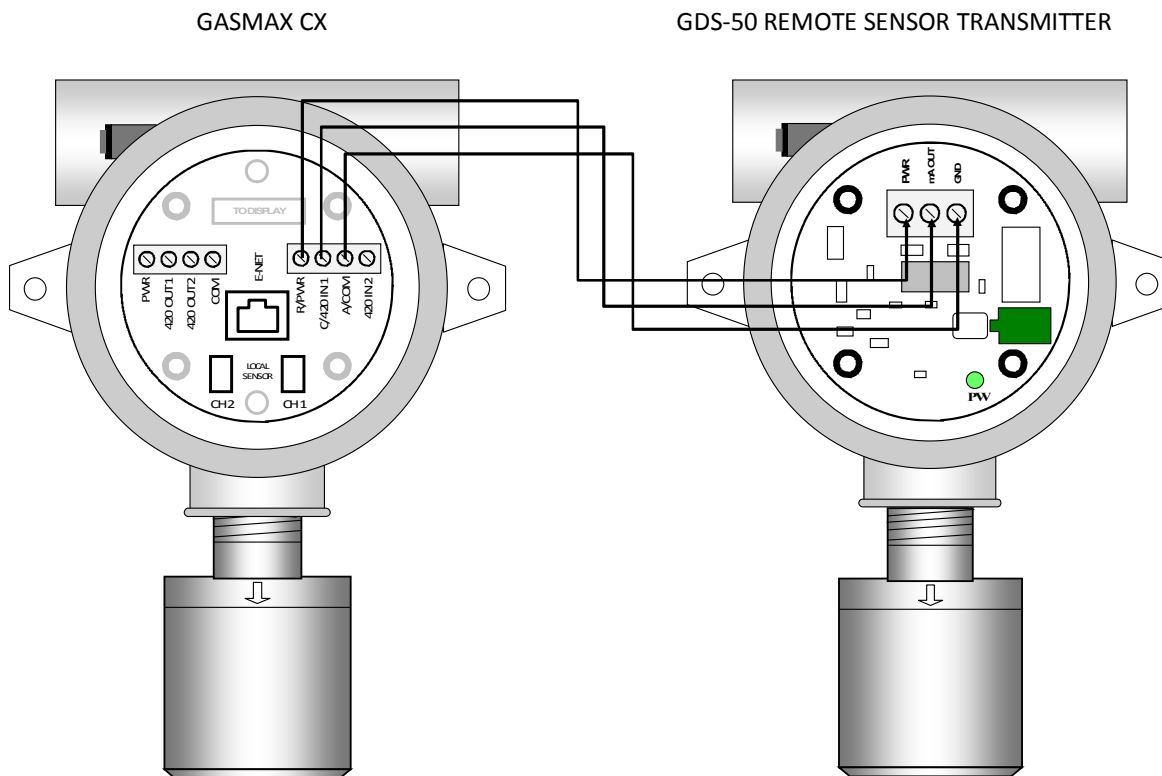

Figure 4-9 Remote Infrared Sensor Transmitter

NOTE: FIELD WIRING FOR REMOTE INFRARED SENSOR TRANSMITTERS IS POLARIZED AND CORRECT WIRING POLARITY MUST BE OBSERVED.

LOCAL GDS-IR INFRARED SENSOR

When the GASMAX CX is configured to include a GDS-IR Infrared Combustible or CO₂ sensor, the IO/Power Supply board is factory modified to make Channel 2 compatible with the sensor's 4-20mA input signal. An integrated "zero set" pushbutton and magnetic zero switch is included inside the GASMAX CX enclosure and is used to periodically set the zero point for the GDS-IR.

GASMAX CX with LOCAL GDS-IR SENSOR

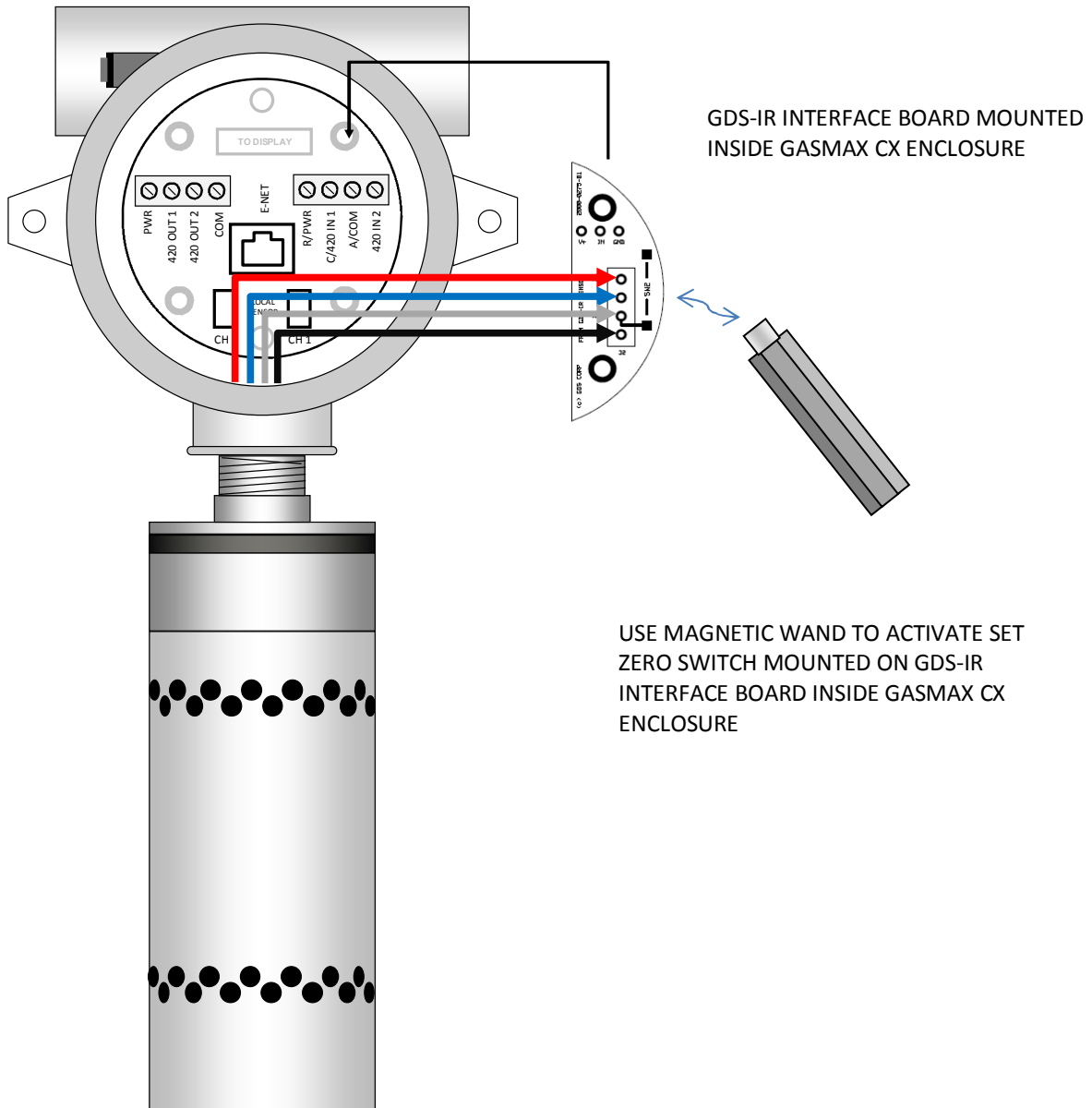

Figure 4-10: Local GDS-IR Infrared Sensor

CONNECTING A REMOTE GDS-IR INFRARED SENSOR

GASMAX CX monitors with remote-mount GDS-IR sensors are shipped in two pieces and sensor wiring must be installed by the end user. GDS-IR sensors can be mounted up to 500 feet from the GASMAX display. Cable used should be **three-wire stranded with foil shield**. GDS Corp recommends Belden B8771. The cable shield must be connected to an earth ground at **ONE END ONLY**. In this configuration the zero-set pushbutton is located in the GDS-IR remote mount junction box.

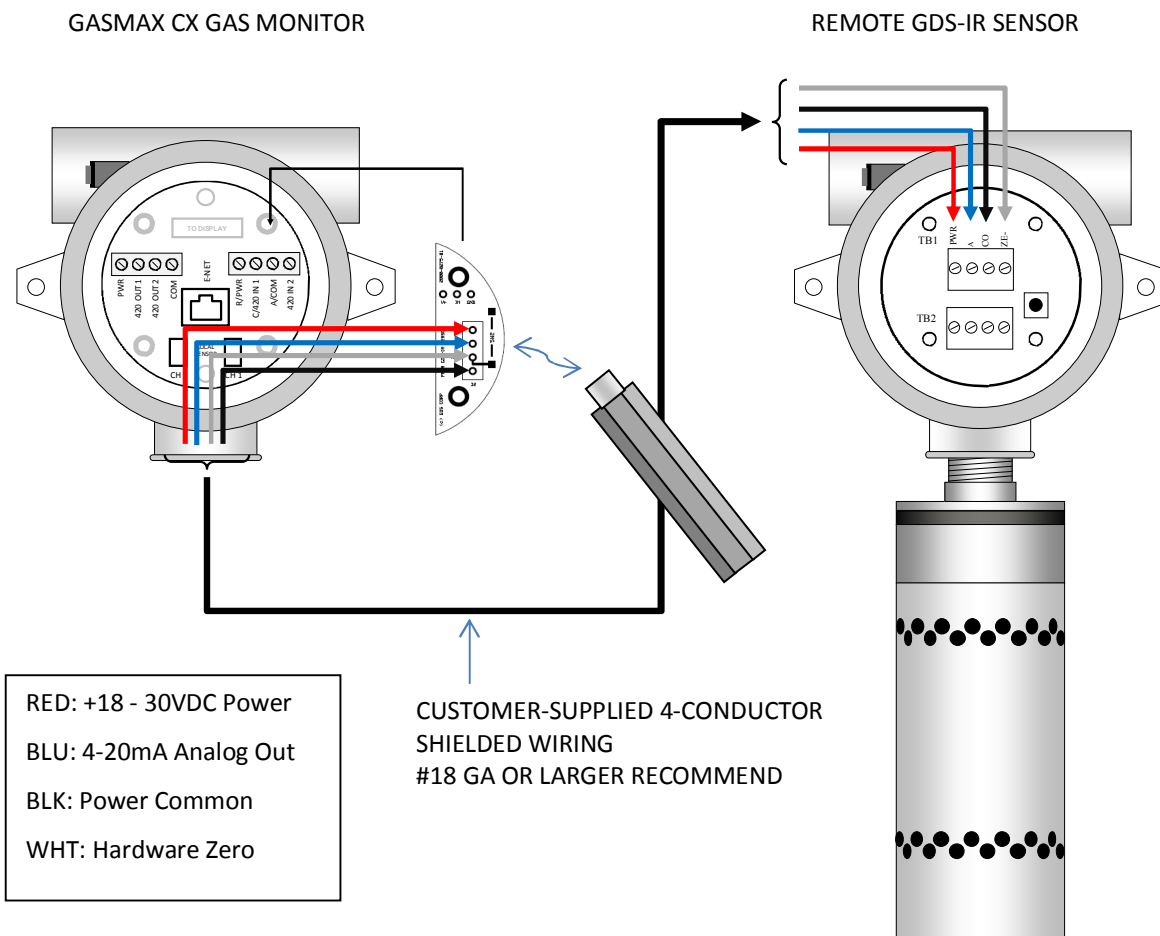

Figure 4-11: Remote GDS-IR Connection

CONNECTING AN EXTERNAL 4-20mA INPUT DEVICE

The GASMAX CX supports two general purpose, non-isolated 4-20mA inputs as shown below. The amount of voltage and current available for the remote 4-20mA device is determined by the GASMAX DC supply connected to TB1. Both channels support local calibration if necessary; if the devices are pre-calibrated, or are calibrated at the source, the calibration feature on each channel can be disabled.

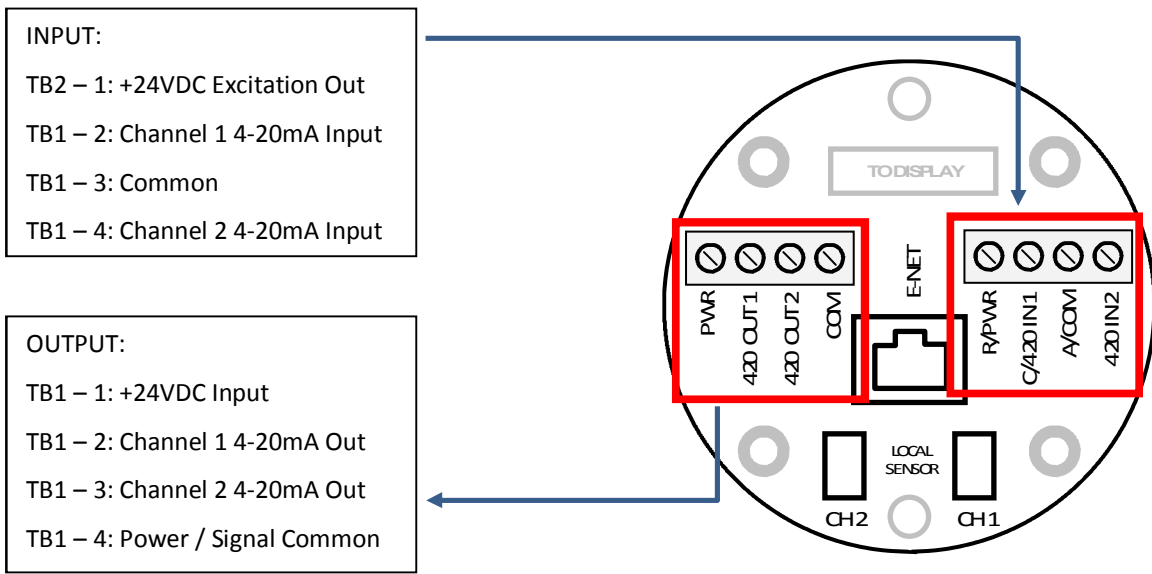

Figure 4-12: Remote 4-20mA Input

5 SETUP AND OPERATION

GASMAX CONTROLS AND DISPLAY

There are four magnetic switches on the face of the GASMAX CX, arranged in a quadrant around the LCD display. Starting in the upper left and proceeding clockwise these are labeled UP, NEXT, EDIT and DN/CAL. To activate, or “press” a magnetic switch, swipe the magnet near the switch. For the balance of this manual, the term “press” will be used to describe activation of any key via the magnetic wand.

Below the LCD display, two LEDs monitor the MODBUS RS-485 or Ethernet network interface. Flashing indicates sent or received data.

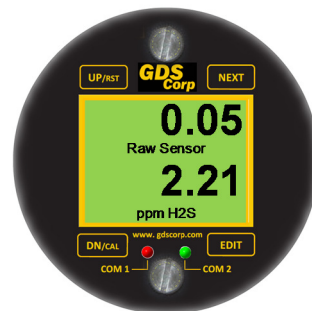

The **EDIT** key activates the USER MENU mode (See Chapter 8). During USER MENU mode, the UP, DN and NEXT keys are used to select and confirm menu entries. The USER MENU allows the operator to view the Event Log and channel parameters and change system settings such as alarm levels and real time clock day and date.

Pressing the **DOWN/CAL** key, followed by the EDIT key, initiates calibration mode. For a detailed description of calibration, see Chapter 6.

When not viewing any of the user menus, pressing the **NEXT** key momentarily causes the GASMAX CX display to sequence between DUAL CHANNEL DATA DISPLAY, CHANNEL 1 TREND DISPLAY, CHANNEL 2 TREND DISPLAY, CHANNEL 1 DATA DISPLAY and CHANNEL 2 DATA DISPLAY as shown below. If only one channel is enabled, the dual channel display mode and corresponding data and trend screens are not included in the rotation.



Figure 5-1: GASMAX CX Display Screen Sequence

DISPLAY SCREENS

The DATA display screen shows a single channel's information. The current value is shown in calibrated engineering units. A horizontal bargraph tracks the current value and shows the Alarm 1 and Alarm 2 values in graphical form. The user-programmable Engineering Units ("Eunits") and programmable Tag Name ("Measurement Name") text strings are shown below the real-time reading. If the channel is in Alarm 1, the background color changes to YELLOW, and if the channel is in Alarm 2, the background color changes to RED.

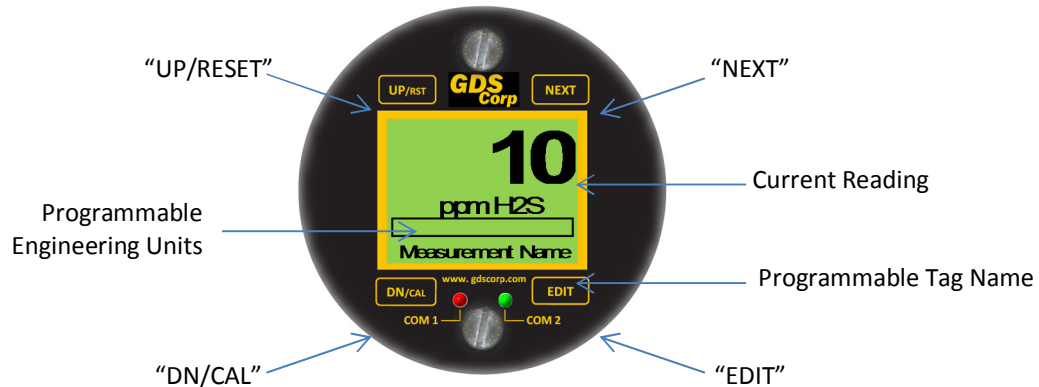

Figure 5-2 GASMAX DATA DISPLAY

Below the LCD display, two LEDs indicate the status of the Ethernet or serial MODBUS communications channels.

The TREND display shows a graph of the most recent 30 minute interval for the channel value. The graph is scaled to match the channels zero and span settings and shows the trend line, real-time value and Alarm 1 and Alarm 2 settings as Yellow and Red horizontal lines.

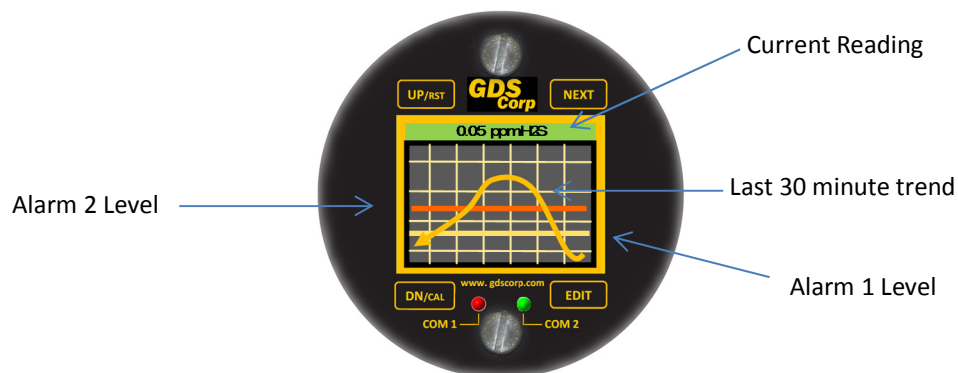

Figure 5-3 GASMAX TREND DISPLAY

INITIAL SETUP

Once installed, apply power to the GASMAX CX and verify that the LCD display is active. Certain sensors may initially indicate off-scale high or low values, but should quickly return to zero if no target gas is present. During this warm-up delay period, the 4-20mA output is held at 4.0 mA to eliminate false alarms in any receiving devices. Warm-up delay is one of the user-adjustable parameters.

Once operational, the user should verify the following settings prior to initial calibration:

Local time and date: Check date value and adjust time for proper time zone.

Tag name or Engineering Units settings: Edit values as necessary.

CAL SPAN GAS value: Set to match concentration of calibration gas cylinder.

CAL MARKER value: Adjust desired output mA during calibration.

ALARM 1, ALARM 2, ALARM 3 settings: Set for desired levels. NOTE: If relays are not installed, GASMAX CX programmable alarm levels affect operation of display color only (Sec 7-3).

Allow the GASMAX CX to stabilize for at least four hours, preferably overnight if possible. This will allow all sensors to reach stable equilibrium with respect to environmental conditions such as ambient temperature, humidity, and barometric pressure as well as applied “reference” and “counter” voltages generated by the GASMAX CX electronics. At this point, the GASMAX CX can be calibrated and made operational.

NORMAL OPERATING MODE

During normal operation, the GASMAX display shows the current gas reading in direct calibrated engineering units. If the reading goes above the Alarm 1 or Alarm 2 values, the display will change color and flash, and the internal relays, if installed and programmed properly, will activate. The 4-20mA outputs will transmit values that represent the % of scale shown on the display. If the sensor malfunctions, or is removed, the display will turn red and the message FAULT will appear on the screen.

ALARM OPERATION – ALARM 1, 2 AND 3

Each channel can be programmed for up to three independent alarm levels, and can be set to alarm ABOVE the target value for BELOW the target value. All programming is done in engineering units that correspond to the channels ZERO and SPAN settings. Alarm processing will trigger an alarm condition when the input exceeds the programmed value, and includes hysteresis to keep the alarm from rapidly switching ON and OFF if the input remains close to the programmed alarm value.

NOTE: ALARM RELAYS ARE NORMALLY TRIGGERED IF EITHER CHANNEL 1 OR CHANNEL 2 ALARM THRESHOLDS ARE EXCEEDED.

NOTE: IF THE OPTIONAL ALARM RELAYS ARE NOT INSTALLED, ALARM SETTINGS AFFECT THE OPERATION OF THE FRONT PANEL DISPLAY ONLY. SEPARATE ALARM SETTINGS MAY NEED TO BE PROGRAMMED IN THE 4-20MA RECEIVING DEVICE.

ALARM OPERATION – FAULT

FAULT is typically used to indicate FAULT conditions that suggest sensor failure or “out of measurement range” conditions.

6 CALIBRATION

CALIBRATION OVERVIEW

Calibration is critically important to ensure correct operation of the GASMAX CX. The built-in CAL MODE function is designed to make calibration quick, easy and error free; a successful ZERO and SPAN calibration requires only four keystrokes. During CAL MODE zero and span, the sensor output is disconnected and the GASMAX CX transmits a fixed mA value, called the CAL MARKER, to notify the receiving device that a calibration is in progress. During the following CAL PURGE DELAY time, the GASMAX CX transmits a fixed 4.0 mA signal to prevent external alarms during calibration. In the case of local or remote Oxygen sensors, during CAL PURGE DELAY the output simulates a typical atmospheric reading of 20.8%. CAL MODE automatically exits if no keystrokes are detected after 5 minutes.

Follow these GASMAX CX calibration guidelines:

- Calibration accuracy is only as good as the calibration gas accuracy. GDS Corp calibration gases are traceable to NIST (National Institute of Standards and Technology).
- **Never use calibration gas that has passed its expiration date.**
- Check the SPAN GAS VALUE setting and make sure it matches the calibration gas. (See Fig. 6-2)
- Always use a GDS Corp calibration cup that completely surrounds the sensor head.
- Be sure to use ZERO AIR, a mixture of 21% oxygen and 79% nitrogen, as a zero reference unless you are certain that no target gas exists in the area. Ambient gas may result in an 'elevated zero' condition that will cause a FAULT to occur once the ambient gas is no longer present.
- **Always calibrate a new sensor before depending on the device for personnel or equipment safety**
- Calibrate on a regular schedule. GDS Corp recommends a full calibration every 3 months, with periodic 'bump tests' on a more frequent basis to ensure that the sensor has not been affected by temperature extremes or the presence of incompatible gases.

CALIBRATION PROCEDURE

Before beginning calibration, make sure you have the following items: A cylinder of calibration gas, fixed flow regulator and an appropriate calibration cup connected to the regulator via a length of flexible tubing. If necessary, a cylinder of 'zero air' may be necessary if the absence of target gas cannot be confirmed. GDS Corp recommends a flow rate of 0.5 liters / minute for standard gases and a flow rate of 1.0 liters / minute for highly reactive gases such as chlorine or chlorine dioxide.

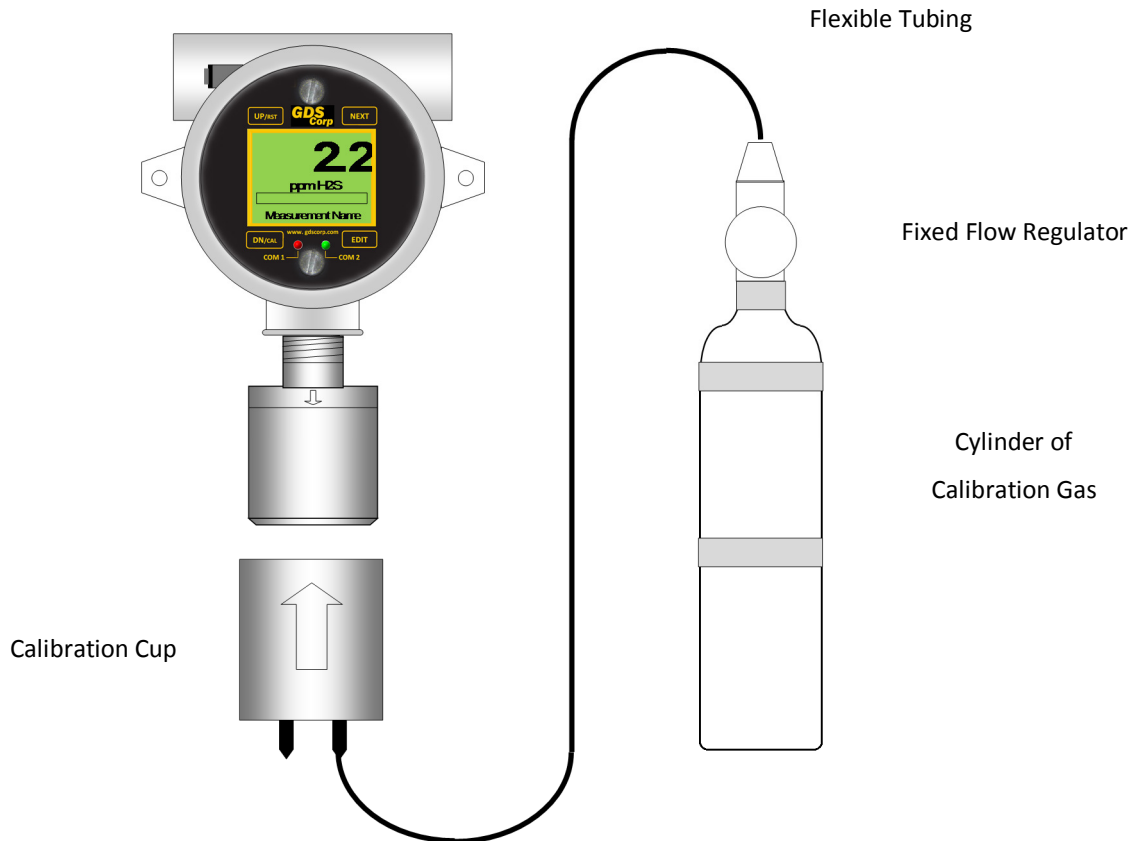

To calibrate a GASMAX CX detector:

1. For dual channel units, press the NEXT key until that the DATA Display screen for the desired channel is shown.
2. To enter CAL MODE, press the DOWN / CAL key and within 5 seconds press the EDIT key.
3. The screen will display an APPLY ZERO message. Using the setup shown in Fig. 5-1, apply clean ZERO air unless it can be guaranteed that no target gas is present. After the reading stabilizes, press the EDIT key to complete the ZERO calibration.
4. If the ZERO CAL SUCCESSFUL message is displayed, an APPLY SPAN message will appear. Apply the correct SPAN gas. After the reading is stable, (approximately 1 minute) press the EDIT key to

complete the SPAN GAS calibration. If the SPAN calibration is successful, the display flashes REMOVE CAL GAS and starts the CAL PURGE delay.

5. Immediately shut off the regulator and remove the calibration cup. At the end of the CAL PURGE delay, the GASMAX EC output is re-enabled and the unit is fully operational.

The flow chart shown in Figure 5-2 illustrates the above procedure. UP, CAL, NEXT & EDIT labels indicate keystrokes using the magnetic wand. ZERO or SPAN calibration will fail if the readings exceed built-in limits for maximum allowable zero or minimum allowable span.

NOTE: A CAL MODE INFO SCREEN IS AVAILABLE TO VIEW CERTAIN CAL MODE PARAMETERS DURING CALIBRATION. HOLD THE UP KEY FOR 5 SECONDS DURING CAL MODE TO DISPLAY THIS SCREEN.

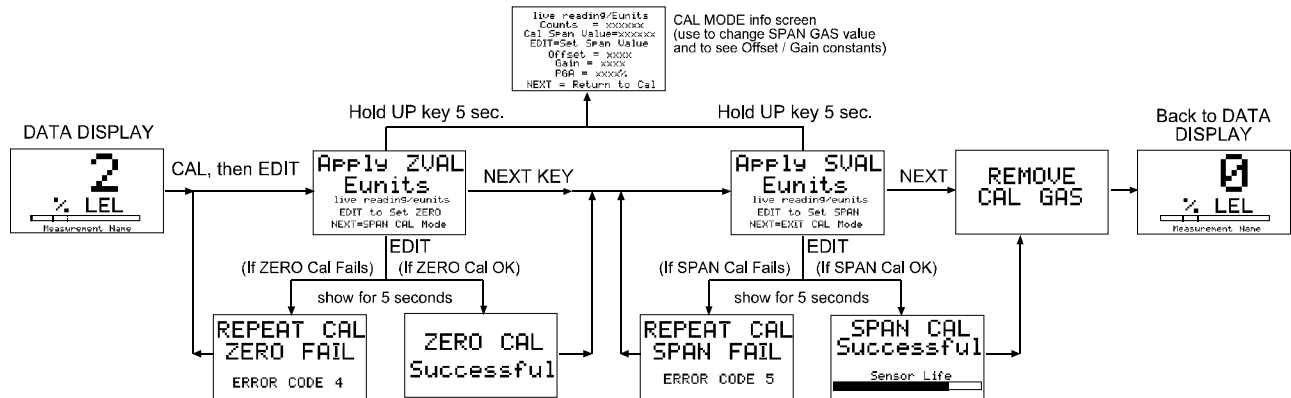

Figure 6-1: Calibration Flowchart

7 MAINTENANCE

NORMAL MAINTENANCE

Normal maintenance for the GASMAX CX primarily involves periodic calibration on standard intervals. GDS Corp recommends calibration at least every three months, or more often if temperature extremes, vibration, the presence of incompatible gases or other environmental factors may accelerate the deterioration of the sensor element. Calibration should also include inspections for clogged or wet sensor heads, cracked or damaged enclosures and water incursion inside conduit or junction boxes.

SENSOR REPLACEMENT – LOCAL SENSORS

If a sensor shows FAULT, does not respond to gas or can no longer be calibrated, it should be replaced. GASMAX CX monitors use GDS Corp type 10-98XX toxic or combustible sensors, where the XX is the gas type, or GDS-IR infrared sensors. For toxic or combustible sensors, the range value should also be specified when ordering replacement sensors. For example, a replacement H2S sensor for 0-100 ppm would be “10-9815-R0100”.

To replace a GASMAX local sensor:

1. Declassify the area or remove power to the GASMAX CX.
2. Unscrew the sensor head cover. If unable to open the cover by hand, use a Sensor Head Replacement Tool (p/n 10-0187).
3. Remove the old sensor by pulling straight down.
4. Carefully install the replacement sensor by aligning the arrow on the sensor with the arrow engraved on the sensor head. Push straight up until the sensor connector seats firmly into the sensor connector.
5. Reinstall the sensor head cover by CAREFULLY screwing the cover onto the sensor head.

NOTE: DO NOT TRY TO UNSCREW THE SENSOR. PULL STRAIGHT DOWN!

NOTE: IF THE SENSOR FALLS OUT OF THE SOCKET DURING THIS STEP, IT CAN BE DAMAGED. USE CAUTION WHEN REINSTALLING THE COVER.

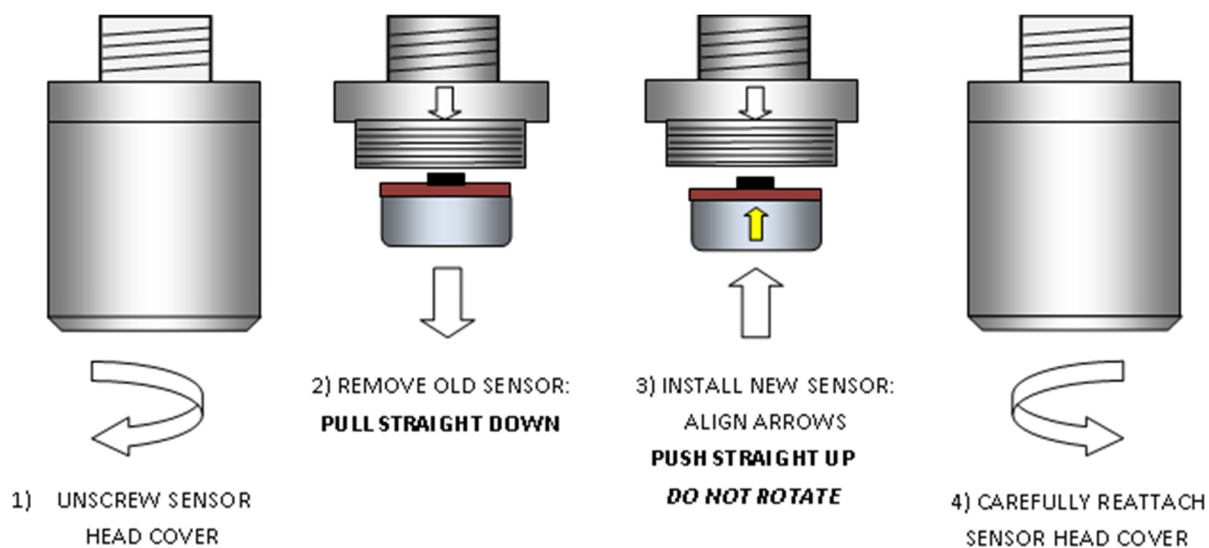

Figure 7-1: GASMAX Sensor Replacement

Local Smart Sensors are automatically recognized by the GASMAX CX and the Smart Sensor identification screen should appear immediately after the installation of a local Smart Sensor. If the sensor is the same gas type as was previously installed, the sensor's calibration data will be uploaded into the GASMAX CX. All other parameters stored in the GASMAX CX will be retained.

GASMAX CX units can be reconfigured for different sensors by simply installing a different type compatible sensor. If a new sensor TYPE is installed, the Smart Sensor identification screen will appear, followed by the ERROR CODE 01 message and the user will be given the opportunity to confirm the new sensor type. If the user activates the EDIT key, all data stored in the new sensor's database – including range, tag name, cal span value, engineering units and alarm levels – will replace the current settings.

SENSOR REPLACEMENT – REMOTE SENSORS

To replace a GASMAX remote sensor:

1. Declassify the area or remove power to the GASMAX CX.
2. Unscrew the sensor head cover. If unable to open the cover by hand, use a Sensor Head Replacement Tool (p/n 10-0187).
3. Remove the old sensor by pulling straight down.

NOTE: DO NOT TRY TO UNSCREW THE SENSOR. PULL STRAIGHT DOWN!

4. Carefully install the replacement sensor by aligning the arrow on the sensor with the arrow engraved on the sensor head. Push straight up until the sensor connector seats firmly into the sensor connector.
5. Reinstall the sensor head cover by CAREFULLY screwing the cover onto the sensor head.
NOTE: IF THE SENSOR FALLS OUT OF THE SOCKET DURING THIS STEP, IT CAN BE DAMAGED. USE CAUTION WHEN REINSTALLING THE COVER.
6. At the GASMAX CX, activate the Main Menu, open the Sensor Information page and select Install New Sensor. This will reset the Sensor Life settings and tell the GASMAX that a new sensor is available.

8 TROUBLESHOOTING

TOXIC SENSOR INDICATES FAULT OR OVERRANGE

- Certain toxic sensors indicate off-scale low or high at power up and quickly drift towards zero. This is normal behavior.
- Toxic sensors showing constant FAULT: If local, remove sensor and examine for moisture or discoloration. Replace sensor if wet or discolored. If remote, check sensor cable and junction box for moisture or standing water. Remove sensor and examine for moisture or discoloration. FAULT indication generally indicates sensor useful life is exhausted.
- Toxic sensors left unpowered for more than 3 months are subject to accelerated degradation and may demonstrate a permanent loss of sensitivity.

TOXIC SENSOR WILL NOT CALIBRATE

- Sensor reading during zero calibration exceeds upper limit of zero – sensor is defective and should be replaced.
- Sensor reading during span calibration too low – sensor may be defective. However, it may be possible to temporarily continue operation by increasing PREAMP GAIN.

BRIDGE SENSOR INDICATES FAULT OR OVERRANGE

- Catalytic bead combustible sensors generally indicate off-scale high at power up and quickly drift towards zero as they reach operating temperature. This is normal behavior.
- Combustibles sensors showing constant OVERRANGE may have defective bead. If remote, check wiring for correct excitation voltage at sensor. Replace sensor.

BRIDGE SENSOR WILL NOT CALIBRATE

- Sensor reading during zero calibration exceeds limits – readjust SENSOR BALANCE to reset zero if possible. If not, sensor is defective and should be replaced.
- Sensor reading during span calibration too low – sensor may be defective. However, it may be possible to temporarily continue operation by increasing PREAMP GAIN. See Section 8.2 for more details.

RECEIVING DEVICE AND GASMAX DISPLAYED VALUES DON'T MATCH

- Check that zero and full scale range values match between GASMAX and receiving device (controller). Use DIAGNOSTICS menu to force GASMAX CX output to 12mA (1/2 scale) and verify appropriate half-scale reading on controller.
- Check for high impedance shorts to ground on 4-20mA wiring.
- If 4-20mA output is off-scale low or high and cannot be adjusted using DIAGNOSTICS mode, IO/Power Supply board may be defective and should be replaced.

CONTROLLER MODBUS DATA INCORRECT

- Verify the MODBUS master is requesting data from registers 31001 for CH 1, 31002 for CH 2.
- Verify that controller MIN and MAX count settings are correct. MIN counts should be "800" which corresponds to 4mA and MAX counts should be "4000" which corresponds to 20 mA.
- Verify that the GASMAX MODBUS address matches the address programmed into the controller's channel configuration.

CONTROLLER SHOWING MODBUS COMM ERROR

- Check for incorrect MODBUS polarity (swap "A" and "B" if unsure; no damage will occur).
- Verify that MODBUS master is requesting data from correct MODBUS address.
- Verify that MODBUS master is requesting correct registers: 31001 for CH 1, 31002 for CH 2.
- Verify that there are no other MODBUS slave devices with identical MODBUS address.

GASMAX DISPLAY BLANK

- Verify DC power at IO/Power Supply board, TB1, terminals 1 (+24) and 4 (Gnd).
- Verify ribbon cable connected between IO/Power Supply board and Display Assembly.

SOFTWARE RESET ("COLD BOOT")

If the GASMAX display shows 'nonsense' characters or one or more of the settings appear to be corrupted, performing a "Cold Boot" will restore the default values in the non-volatile memory and may clear the problem. To perform a 'Cold Boot', hold the magnetic wand over the EDIT key while applying power.

Note that a COLD BOOT will reset certain values to their default setting, including the MODBUS address value. If a Smart Sensor is connected to a local sensor head, the GASMAX will reload the sensor type, range, cal span value and other sensor –related values automatically.

9 SPECIFICATIONS

Model	GASMAX CX Single / Dual Channel Gas Monitor
Power Input	10-30VDC at < 10 watts with relay board. Additional power required for Extended Temp & GDS-IR option.
Display	Full color LCD with engineering units, bargraph and 30-minute trend
Channel One Input	Digital input for GDS Corp 10-98xx Smart Toxic Sensors Bridge input for GDS Corp 10-98xx Catalytic Bead, SmartIR or PID sensors Analog 4-20mA input
Channel Two Input	Digital input for GDS Corp 10-98xx Smart Toxic Sensors Analog 4-20mA input
Accuracy	+/- 5% of full scale (typical)
Standard Output	Dual three-wire 4-20mA current source outputs with fault and overrange indication. Maximum loop resistance is 750 ohms with standard 24VDC supply
Optional Output	Relay / MODBUS interface with 4x 5A SPDT programmable alarm relays Dual channel MODBUS interface
Temperature	Electronics -40°C to +60°C. See Sensor Manual for additional details
Memory	On-board non-volatile memory retains all user settings
Housing	Aluminum housing with epoxy paint standard; #316 stainless steel optional One ¾" NPT female connection for local sensor head Two ¾" NPT female connections for conduit or cable glands
Dimensions	Width 5.4" (137 mm), Height 8" (203 mm), Depth 5" (127 mm) Shipping weight 6.5 pounds (3 kg)
Approvals	CSA Certified Division 1 & 2 Groups B, C, D. Suitable for explosion-proof installations with flame arrestor
Warranty	Two years on electronics, one year on sensor

10 USER MENUS

The GASMAX CX gas monitor used in the GDS-68XP has a menu-driven user interface that allows the operator to review and adjust a wide range of settings. In the GDS-68XP, channel 1 of the GASMAX CX measures the “raw sensor” gas level and channel 2 provides continuous display, output and alarming on the stored value retained in the sequencer memory.

To access the Main Menu, activate the EDIT key with a magnetic wand.

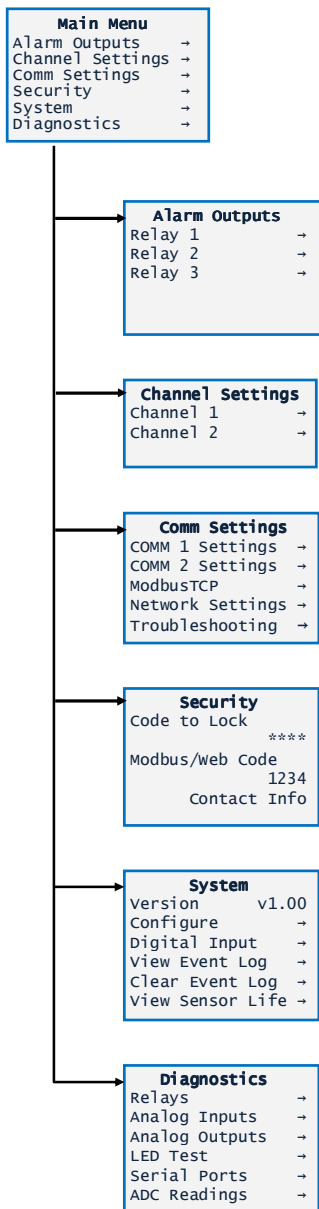
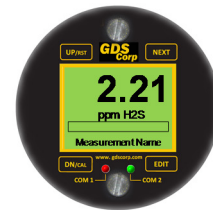

Alarm Output Menu – contains settings that control the four optional alarm relays (if installed). These setting include relay programming, on and off delay, failsafe mode and specific input override.

Channel Settings Menu – contains settings specific to each channel. These include tag names, range, calibration settings and alarm levels.

Comm Settings Menu – contains settings specific to the Ethernet network interface, MODBUS/TCP interface and optional RS-485 serial ports (if installed).

Security Settings Menu – allows the user to restrict operation for some or all of the features as well as provide a programmed contact name.

System Settings Menu – contains settings that are unit specific. These include unit name. time and date, warm-up and calibration delay settings, and Event Log.

Diagnostics Menu – comprehensive set of tools that can be used to activate relays, simulate output values and test serial ports.

Figure 10-1: Main Menu Tree

ALARM OUTPUTS MENU

The Alarm Outputs Menu controls the four optional alarm relays (if installed). These settings include relay programming, acknowledge, failsafe mode and specific input override options.

NOTE: The Alarm / Modbus board containing the 3x alarm relays and 1x fault relay is optional on the GDS-68XP.

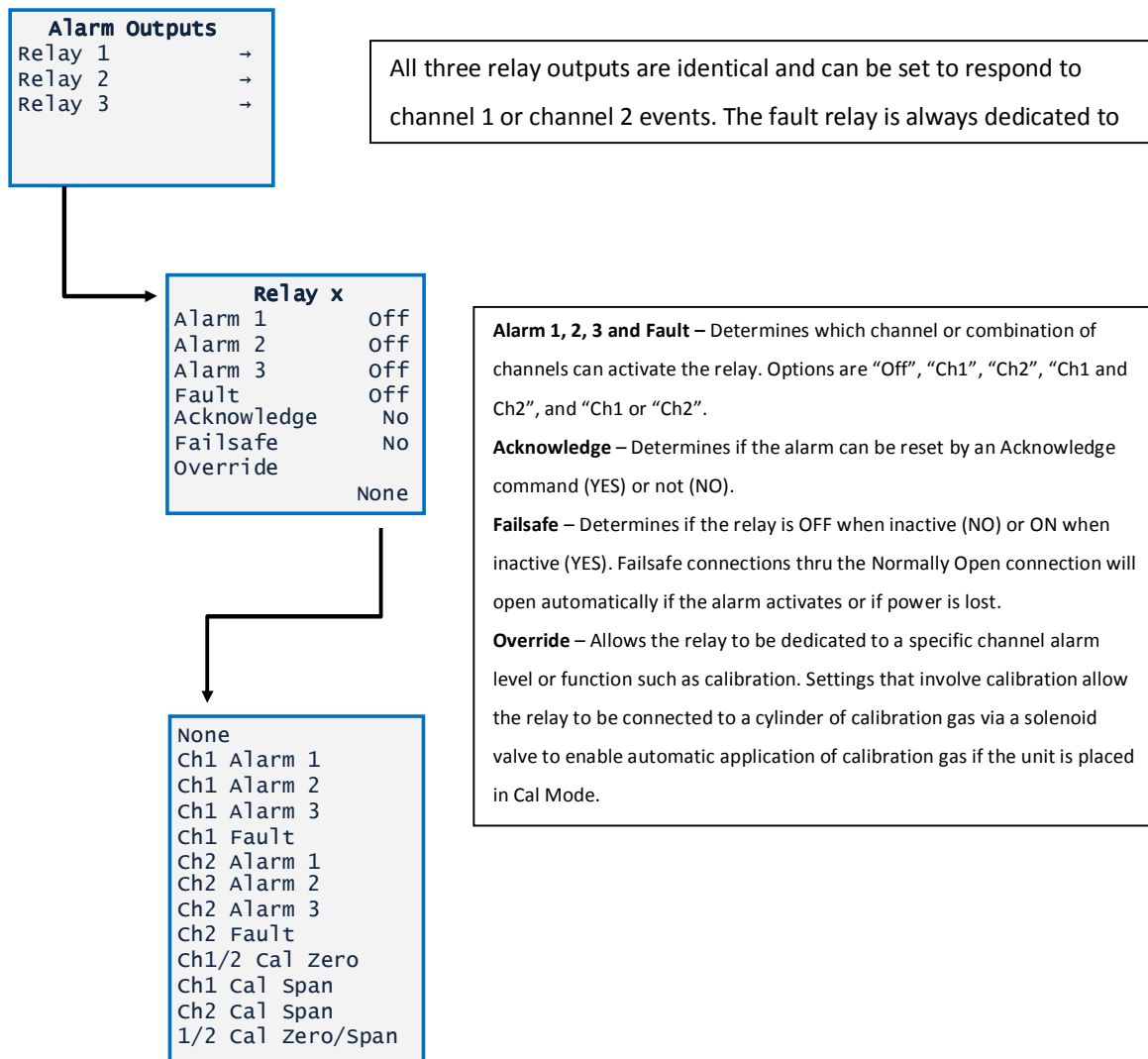

Figure 10-2: Alarm Outputs Menu Tree

CHANNEL SETTINGS MENU

The Channel Settings Menu allows the user to adjust individual channel or sensor-specific features. Data in the Channel Settings Menu is uploaded from Smart Sensors, and written back to any local Smart Sensor if changed in the menu.

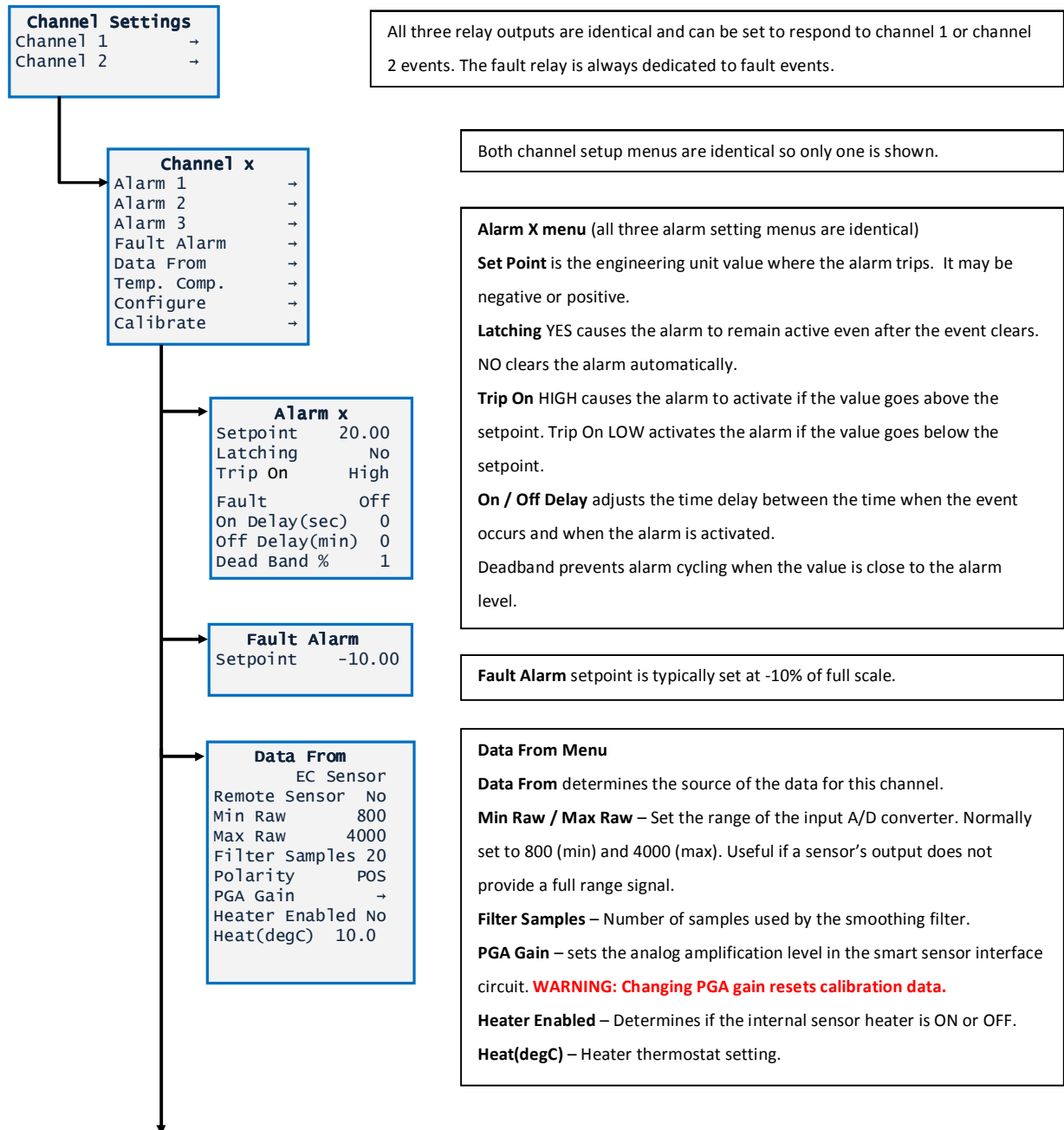
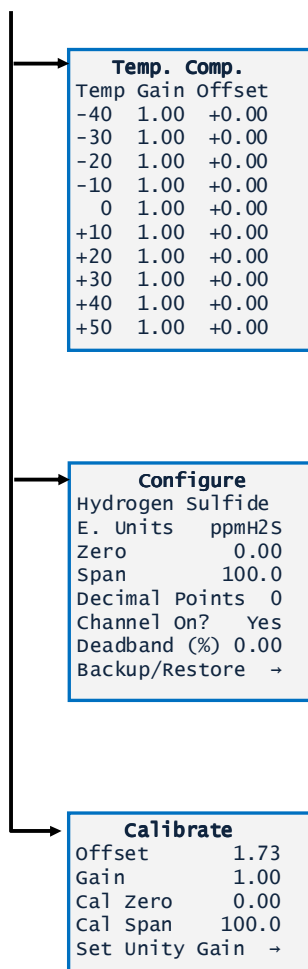

Figure 10-3: Channel Settings Menu Tree (1)



Temperature Compensation compensates for changes in sensor output (gain) and zero value (offset) as sensor temperature changes. Individual values for gain and offset can be entered for eleven points ranging from minus 40C to +60C. Gain and offset values are linearly interpolated between points by the internal microprocessor.

NOTE: These values are typically set by the sensor manufacturer and should not be changed.

Configure Menu

Measurement Name – User-programmable character string to describe the channel. Otherwise called “tag name”.

E. Units – User-programmable character string that describes the engineering units value.

Zero – Channel zero value, typically “0”.

Span– Channel full scale value. Max value is “9999”.

Decimal Points – Determines the number of displayed digits to the right of the decimal point.

Channel On? – Channel ON or OFF setting. An “OFF” channel will have no effect on any alarm or output value.

Deadband (%) – The value, around zero, for which the screen will show “0.0”. Eliminates display of small values around zero due to sensor drift.

Calibrate Menu

Offset – Shows the computed offset value based on the latest calibration.

Gain – Shows the computed gain value based on the latest calibration.

Cal Zero – The value for the zero point calibration

Cal Span – The value for span calibration, typically 50% of full scale.

Set Unity Gain – Clears gain and offset to “1.00” and “0.00” respectively.

WARNING: Set Unity Gain resets calibration data.

Figure 10-4: Channel Settings Menu Tree (2)

COMM SETTINGS MENU

The Comm Settings Menu allows the user to configure the Ethernet interface, MODBUS/TCP slave and two optional RS-485 serial interfaces.

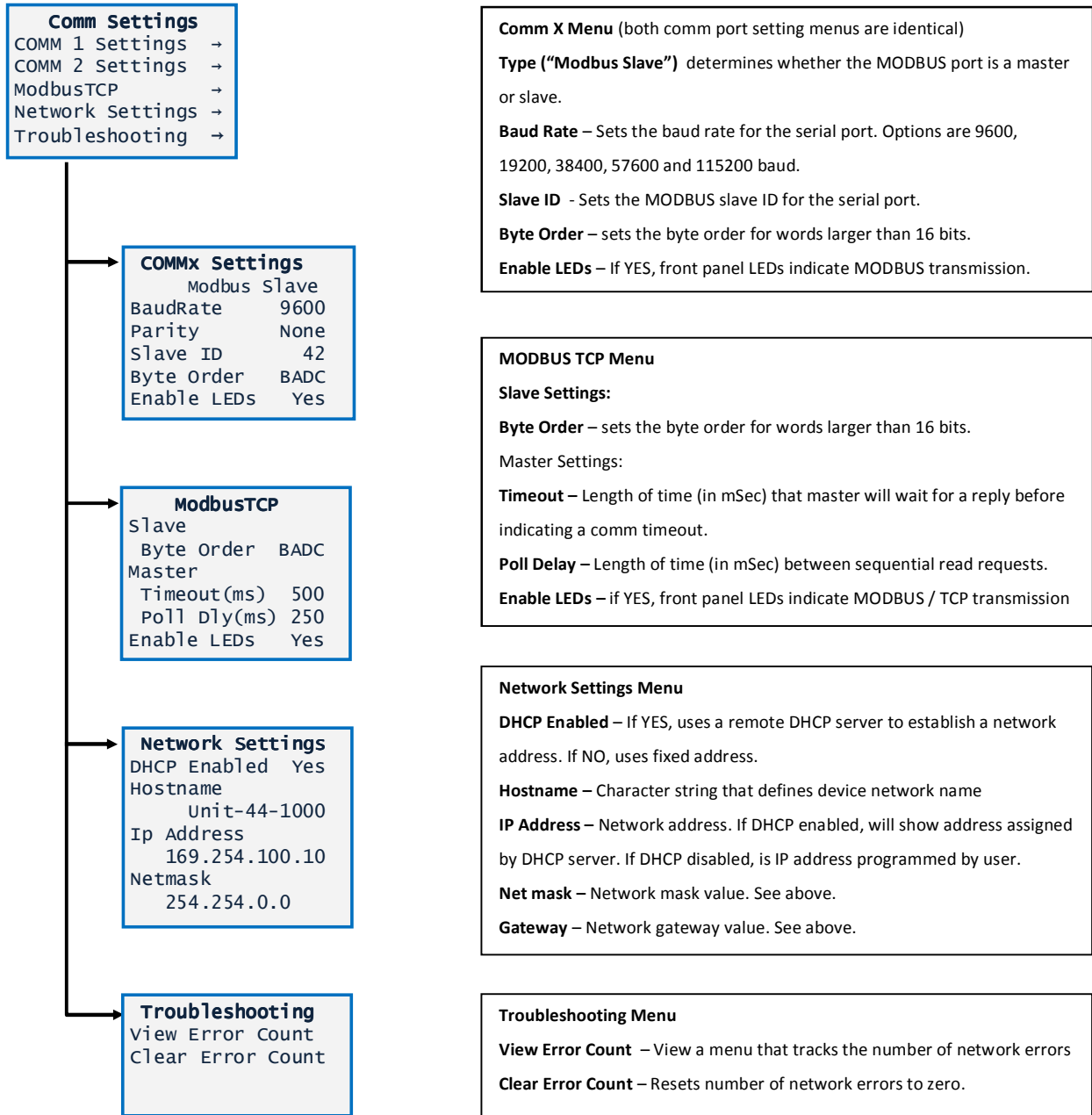

Figure 10-5: Comm Settings Menu

SYSTEM SETTINGS MENU

The Comm Settings Menu allows the user to configure the Ethernet interface, MODBUS/TCP slave and two optional RS-485 serial interfaces.

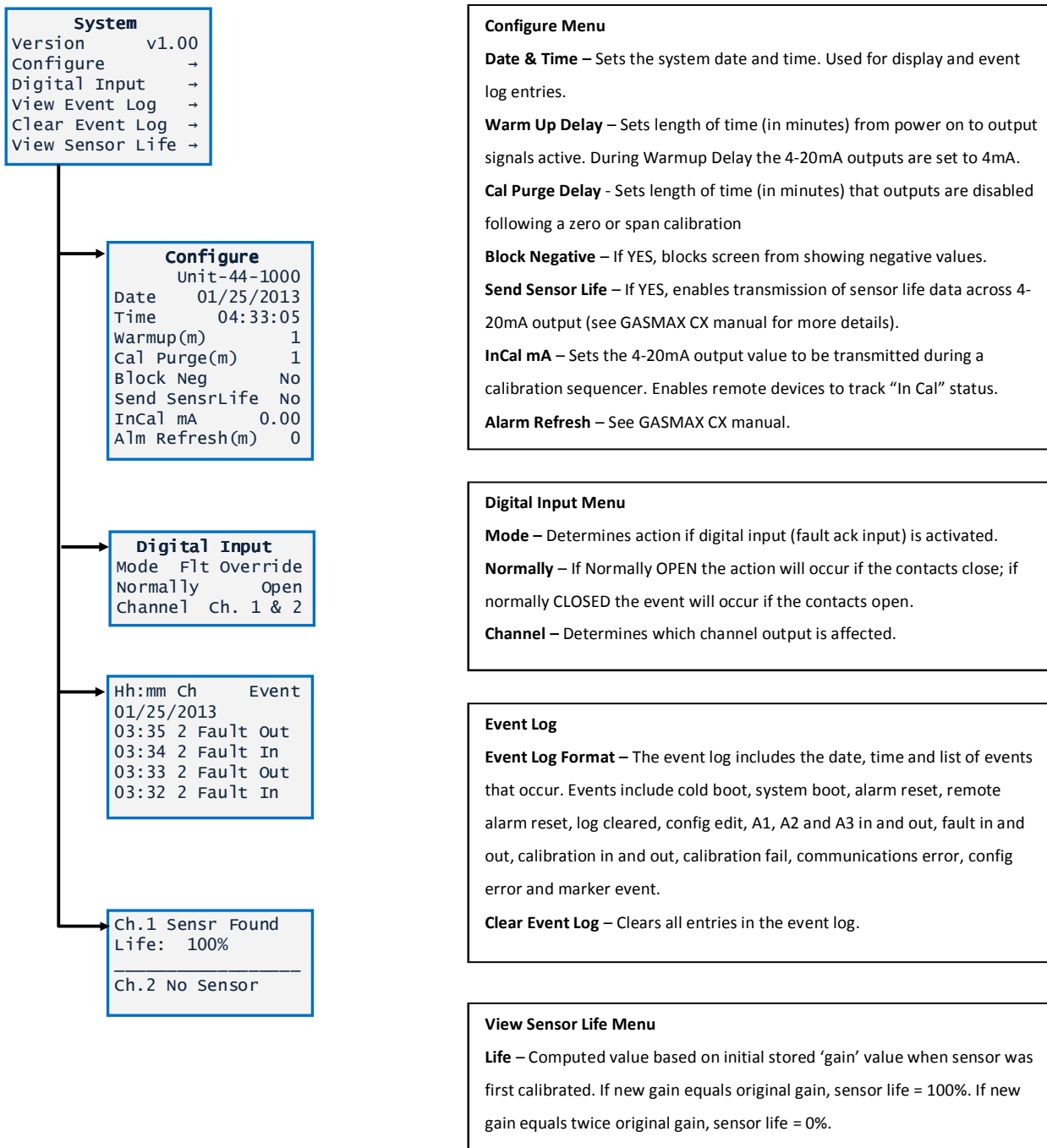

Figure 10-6: System Settings Menu Tree

DIAGNOSTICS MENU

The Diagnostics page provides tools for use during setup or testing. Tests for optional features are not available if the feature is not installed.

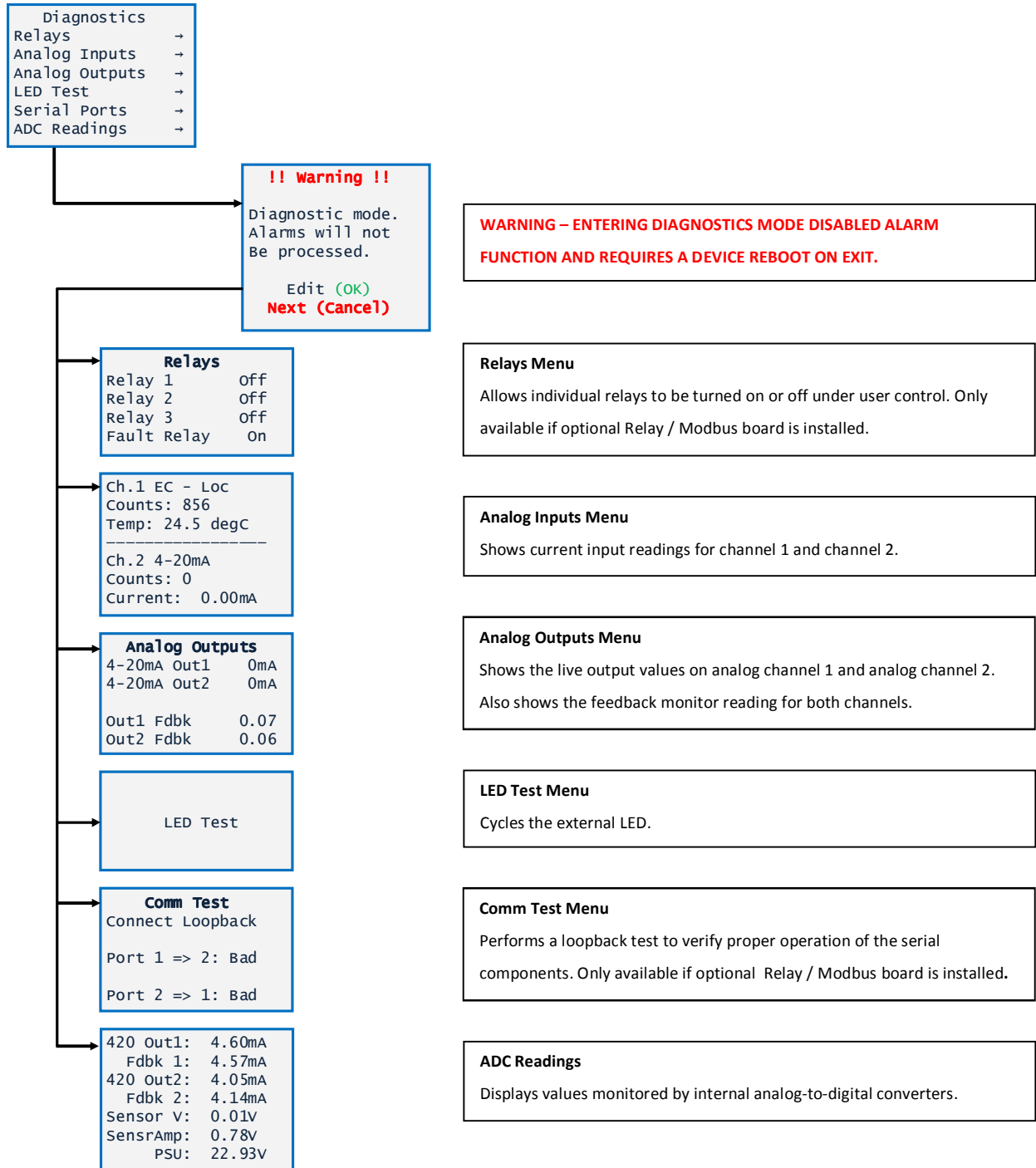

Figure 10-7: Diagnostics Menu Tree

11 NETWORK INTERFACE

MODBUS REGISTERS

The GASMAX CX features a full complement of user-accessible MODBUS registers that can provide a complete snapshot of the gas detector configuration. This includes all real-time data, preset zero, span and calibration values and user-programmable text.

Variable Name	Alias	Read	Write	Notes
Ch 1 Analog Output Raw	31001	4	N/A	12 bit value; 800 = 4mA, 4000 = 20mA
Ch 2 Analog Output Raw	31002	4	N/A	12 bit value; 800 = 4mA, 4000 = 20mA
Ch 1 A2D Raw Counts	31003	4	N/A	12 bit value from A/D converter
Ch 2 A2D Raw Counts	31004	4	N/A	12 bit value from A/D converter
Ch 1 Sensor Life	31009	4	N/A	16 bit signed integer ranging from -1 to 100 where -1 indicates Cal Required
Ch 2 Sensor Life	31010	4	N/A	16 bit signed integer ranging from -1 to 100 where -1 indicates Cal Required
Ch 1 Sensor Temp	31011	4	N/A	16 bit integer from 1 to 4095 scaled for -55°C to +125°C
Ch 2 Sensor Temp	31012	4	N/A	16 bit integer from 1 to 4095 scaled for -55°C to +125°C
Ch 1 4-20mA Out FP	31210	4	N/A	32 bit floating point
Ch 2 4-20mA Out FP	31212	4	N/A	32 bit floating point
Ch 1 Output Feedback FP	31214	4	N/A	32 bit floating point
Ch 2 Output Feedback FP	31216	4	N/A	32 bit floating point
12V Input FP	31218	4	N/A	32 bit floating point
Sensor Volts FP	31220	4	N/A	32 bit floating point
Bridge Amp FP	31222	4	N/A	32 bit floating point
Bridge Out FP	31224	4	N/A	32 bit floating point
Product ID	32001	4	N/A	Factory use only
Version	32002	4	N/A	Factory use only
Custom Feature	32003	4	N/A	Factory use only
Customer ID	32004	4	N/A	Factory use only
Lock Status	32005	4	N/A	
Boot Year	32006	4	N/A	Last power-up time & date
Boot Month	32007	4	N/A	Last power-up time & date
Boot Day	32008	4	N/A	Last power-up time & date
Boot Hour	32009	4	N/A	Last power-up time & date
Boot Minute	32010	4	N/A	Last power-up time & date
Boot Second	32011	4	N/A	Last power-up time & date
SR 1 State	32020	4	N/A	True if relay #1 active

SR 2 State	32021	4	N/A	True if relay #2 active
SR 3 State	32022	4	N/A	True if relay #3 active
FR State	32023	4	N/A	True if fault relay active
Warmup	32025	4	N/A	True if unit in warm-up
SR 1 Flashing	32026	4	N/A	True if relay #1 flashing
SR 2 Flashing	32027	4	N/A	True if relay #2 flashing
SR 3 Flashing	32028	4	N/A	True if relay #3 flashing
FR Flashing	32029	4	N/A	True if fault relay flashing
DI State	32034	4	N/A	Digital input status
Ch 1 Fixed Point	33001	4	N/A	Compatible with GASMAX II
CH 2 Fixed Point	33002	4	N/A	Compatible with GASMAX II
Ch 1 Floating Point	33010	4	N/A	32 bit IEEE 754 float
Ch 1 Value String	33012	4	N/A	6 character string, zero terminated
Ch 1 Temperature Float	33015	4	N/A	Sensor temperature
Ch 1 A1 Status	33017	4	N/A	True if alarm 1 active
Ch 1 A1 Flashing	33018	4	N/A	True if alarm 1 indicator flashing
Ch 1 A2 Status	33019	4	N/A	True if alarm 2 active
Ch 1 A2 Flashing	33020	4	N/A	True if alarm 2 indicator flashing
Ch 1 A3 Status	33021	4	N/A	True if alarm 3 active
Ch 1 A3 Flashing	33022	4	N/A	True if alarm 3 indicator flashing
Ch 1 Fault Status	33023	4	N/A	True if fault active
Ch 1 Comm Error	33024	4	N/A	True if comm error
Ch 1 Config Error	33025	4	N/A	True if config error
Ch 1 I/O Error	33026	4	N/A	True if input/output error
Ch 1 Cal Flag	33027	4	N/A	True if calibration in progress
Ch 1 Marker Flag	33028	4	N/A	True if marker active
Ch 1 Linearize	33029	4	N/A	True if linearization table active
Ch 1 Err Flashing	33030	4	N/A	True if channel error
Ch 2 Floating Point	33040	4	N/A	32 bit IEEE 754 float
Ch 2 Value String	33042	4	N/A	6 character string, zero terminated
Ch 2 Temp Float	33045	4	N/A	Sensor temperature
Ch 2 A1 Status	33047	4	N/A	True if alarm 1 active
Ch 2 A1 Flashing	33048	4	N/A	True if alarm 1 indicator flashing
Ch 2 A2 Status	33049	4	N/A	True if alarm 2 active
Ch 2 A2 Flashing	33050	4	N/A	True if alarm 2 indicator flashing
Ch 2 A3 Status	33051	4	N/A	True if alarm 3 active
Ch 2 A3 Flashing	33052	4	N/A	True if alarm 3 indicator flashing
Ch 2 Fault Status	33053	4	N/A	True if fault active
Ch 2 Comm Error	33054	4	N/A	True if comm error
Ch 2 Config Error	33055	4	N/A	True if config error

Ch 2 I/O Error	33056	4	N/A	True if input/output error
Ch 2 Cal Flag	33057	4	N/A	True if calibration in progress
Ch 2 Marker Flag	33058	4	N/A	True if marker active
Ch 2 Linearize	33059	4	N/A	True if linearization table active
Ch 2 Err Flashing	33060	4	N/A	True if channel error
Alarm Reset	40001	N/A	3	Write to acknowledge alarm
System Name	40010	4	N/A	16 character ASCII text
Date Year	40020	3	N/A	Current time & date
Date Month	40021	3	N/A	Current time & date
Date Day	40022	3	N/A	Current time & date
Date Hour	40023	3	N/A	Current time & date
Date Minute	40024	3	N/A	Current time & date
Date Second	40025	3	N/A	Current time & date
Refresh Time	40026	3	N/A	Alarm refresh (minutes)
Warmup Time	40027	3	N/A	Warm up delay (minutes)
Cal Purge Time	40028	3	N/A	Cal purge delay (minutes)
Block Negative Flag	40029	3	N/A	True if prohibit display of neg values
Comm 1 Function	40030	3	N/A	MODBUS serial port #1
Comm 1 Baud Rate	40031	3	N/A	MODBUS serial port #1
Comm 1 Parity	40032	3	N/A	MODBUS serial port #1
Comm 1 Slave ID	40033	3	N/A	MODBUS serial port #1
Comm 1 Timeout	40034	3	N/A	MODBUS serial port #1
Comm 1 Poll Delay	40035	3	N/A	MODBUS serial port #1
Comm 1 Byte Order	40036	3	N/A	MODBUS serial port #1
Comm 1 Wireless T/O	40037	3	N/A	MODBUS serial port #1
Comm 1 LED Enable	40038	3	N/A	MODBUS serial port #1
Comm 2 Function	40040	3	N/A	MODBUS serial port #2
Comm 2 Baud Rate	40041	3	N/A	MODBUS serial port #2
Comm 2 Parity	40042	3	N/A	MODBUS serial port #2
Comm 2 Slave ID	40043	3	N/A	MODBUS serial port #2
Comm 2 Timeout	40044	3	N/A	MODBUS serial port #2
Comm 2 Poll Delay	40045	3	N/A	MODBUS serial port #2
Comm 2 Byte Order	40046	3	N/A	MODBUS serial port #2
Comm 2 Wireless T/O	40047	3	N/A	MODBUS serial port #2
Comm 2 LED Enable	40048	3	N/A	MODBUS serial port #2
DHCP Enabled	40050	3	N/A	Ethernet port; DHCP or fixed address
Host Name	40051	3	N/A	Ethernet port: 16 ASCII characters
IP Address	40066	3	N/A	Ethernet port: xxx.xxx.xxx.xxx
Net Mask	40070	3	N/A	Ethernet port: xxx.xxx.xxx.xxx

Gateway IP	40074	3	N/A	Ethernet port: xxx.xxx.xxx.xxx
Modbus TCP Byte Order	40080	3	N/A	MODBUS/TCP function
Modbus TCP Timeout	40081	3	N/A	MODBUS/TCP timeout (mSec)
Modbus TCP Poll Delay	40082	3	N/A	MODBUS/TCP poll delay (mSec)
Save Config	40095	N/A	3	Write command to save local config
Config Changed	40096	3	N/A	True if config changed since last read
Security Unlock	40099	3	N/A	TBD
Relay 1 A1 Votes	40101	3	N/A	Alarm relay #1 configuration
Relay 1 A2 Votes	40102	3	N/A	Alarm relay #1 configuration
Relay 1 A3 Votes	40103	3	N/A	Alarm relay #1 configuration
Relay 1 Fault Votes	40104	3	N/A	Alarm relay #1 configuration
Relay 1 Override	40105	3	N/A	Alarm relay #1 configuration
Relay 1 Ack	40107	3	N/A	Alarm relay #1 configuration
Relay 1 Failsafe	40108	3	N/A	Alarm relay #1 configuration
Relay 2 A1 Votes	40111	3	N/A	Alarm relay #2 configuration
Relay 2 A2 Votes	40112	3	N/A	Alarm relay #2 configuration
Relay 2 A3 Votes	40113	3	N/A	Alarm relay #2 configuration
Relay 2 Fault Votes	40114	3	N/A	Alarm relay #2 configuration
Relay 2 Override	40115	3	N/A	Alarm relay #2 configuration
Relay 2 Ack	40117	3	N/A	Alarm relay #2 configuration
Relay 2 Failsafe	40118	3	N/A	Alarm relay #2 configuration
Relay 3 A1 Votes	40121	3	N/A	Alarm relay #3 configuration
Relay 3 A2 Votes	40122	3	N/A	Alarm relay #3 configuration
Relay 3 A3 Votes	40123	3	N/A	Alarm relay #3 configuration
Relay 3 Fault Votes	40124	3	N/A	Alarm relay #3 configuration
Relay 3 Override	40125	3	N/A	Alarm relay #3 configuration
Relay 3 Ack	40127	3	N/A	Alarm relay #3 configuration
Relay 3 Failsafe	40128	3	N/A	Alarm relay #3 configuration
Force Sensor Upload	40141	3	N/A	Binary
Digital Input Mode	40150	3	N/A	Alarm ack or flow switch input
Digital Input Type	40151	3	N/A	Alarm ack or flow switch input
Digital Input Mode	40152	3	N/A	Alarm ACK or flow switch input
Send Sensor Life	40153	3	N/A	True if transmit sensor life value
Contact Info String	40160	3	N/A	16 ASCII characters (2 per register)
Ch 1 Measurement Name	40401	3	N/A	16 ASCII characters (2 per register)
Ch 2 Measurement Name	40409	3	N/A	16 ASCII characters (2 per register)
Ch 1 EUNITS	40423	3	N/A	10 ASCII characters (2 per register)
Ch 2 EUNITS	40428	3	N/A	10 ASCII characters (2 per register)

Ch 1 Preamp gain	40433	3	N/A	Contact factory
Ch 2 Preamp gain	40434	3	N/A	Contact factory
Ch 1 Cal Zero	42001	3	N/A	Modbus 32 bit IEEE 754 Floating Pt
Ch 1 Cal Span	42003	3	N/A	Modbus 32 bit IEEE 754 Floating Pt
Ch 1 Zero Value	42005	3	N/A	Modbus 32 bit IEEE 754 Floating Pt
Ch 1 Span Value	42007	3	N/A	Modbus 32 bit IEEE 754 Floating Pt
Ch 1 Fault Value	42009	3	N/A	Modbus 32 bit IEEE 754 Floating Pt
Ch 1 Alarm 1 Setpoint	42011	3	N/A	Modbus 32 bit IEEE 754 Floating Pt
Ch 1 Alarm 2 Setpoint	42013	3	N/A	Modbus 32 bit IEEE 754 Floating Pt
Ch 1 Alarm 3 Setpoint	42015	3	N/A	Modbus 32 bit IEEE 754 Floating Pt
Ch 1 Manual Gain	42017	3	N/A	Modbus 32 bit IEEE 754 Floating Pt
Ch 1 Manual Offset	42019	3	N/A	Modbus 32 bit IEEE 754 Floating Pt
Ch 2 Cal Zero Value	42021	3	N/A	Modbus 32 bit IEEE 754 Floating Pt
Ch 2 Cal Span Value	42023	3	N/A	Modbus 32 bit IEEE 754 Floating Pt
Ch 2 Zero Value	42025	3	N/A	Modbus 32 bit IEEE 754 Floating Pt
Ch 2 Span Value	42027	3	N/A	Modbus 32 bit IEEE 754 Floating Pt
Ch 2 Fault Value	42029	3	N/A	Modbus 32 bit IEEE 754 Floating Pt
Ch 2 Alarm 1 Setpoint	42031	3	N/A	Modbus 32 bit IEEE 754 Floating Pt
Ch 2 Alarm 2 Setpoint	42033	3	N/A	Modbus 32 bit IEEE 754 Floating Pt
Ch 2 Alarm 3 Setpoint	42035	3	N/A	Modbus 32 bit IEEE 754 Floating Pt
Ch 2 Manual Gain	42037	3	N/A	Modbus 32 bit IEEE 754 Floating Pt
Ch 2 Manual Offset	42039	3	N/A	Modbus 32 bit IEEE 754 Floating Pt
Ch 1 Alarm 1 Latch	43001	3	N/A	False = NO, True = YES
Ch 1 Alarm 1 Trip	43002	3	N/A	False = HIGH, True = LOW
Ch 1 Alarm 1 On Delay	43003	3	N/A	Activation delay in seconds
Ch 1 Alarm 1 Off Delay	43004	3	N/A	Deactivation delay in minutes
Ch 1 Alarm 1 Hysteresis	43005	3	N/A	Percent of scale
Ch 1 Alarm 2 Latch	43011	3	N/A	False = NO, True = YES
Ch 1 Alarm 2 Trip	43012	3	N/A	False = HIGH, True = LOW
Ch 1 Alarm 2 On Delay	43013	3	N/A	Activation delay in seconds
Ch 1 Alarm 2 Off Delay	43014	3	N/A	Deactivation delay in minutes
Ch 1 Alarm 2 Hysteresis	43015	3	N/A	Percent of scale
Ch 1 Alarm 2 Color	43016	3	N/A	TBD
Ch 1 Alarm 3 Latch	43021	3	N/A	False = NO, True = YES
Ch 1 Alarm 3 Trip	43022	3	N/A	False = HIGH, True = LOW
Ch 1 Alarm 3 On Delay	43023	3	N/A	Activation delay in seconds
Ch 1 Alarm 3 Off Delay	43024	3	N/A	Deactivation delay in minutes
Ch 1 Alarm 3 Hysteresis	43025	3	N/A	Percent of scale
Ch 1 Alarm 3 Color	43026	3	N/A	TBD
Ch 1 Alarm 3 Enabled	43027	3	N/A	False = NO, True = YES

Ch 1 Data From	43031	3	N/A	Selection
Ch 1 Min Raw	43032	3	N/A	Binary (800)
Ch 1 Max Raw	43033	3	N/A	Binary (4000)
Ch 1 Remote ID	43034	3	N/A	Binary
Ch 1 Interface	43035	3	N/A	Binary
Ch 1 Byte Order	43036	3	N/A	Byte order
Ch 1 Alias	43037	3	N/A	Binary, 32 bit, 2x
Ch 1 IP Address	43039	3	N/A	Binary, 4x unsigned bytes
Ch 1 Port	43041	3	N/A	Binary, 32 bit, 2x
Ch 1 Remote Sensor	43043	3	N/A	Binary
Ch 1 DP	43079	3	N/A	Number of decimal points
Ch 1 Enable	43080	3	N/A	False = NO, True = YES
Ch 1 Deadband	43081	3	N/A	Modbus 32 bit IEEE 754 Floating Pt
Ch 1 Marker Enable	43083	3	N/A	False = NO, True = YES
Ch 1 Marker Percent	43084	3	N/A	Modbus 32 bit IEEE 754 Floating Pt
Ch 1 Marker Info	43086	3	N/A	6 ASCII characters
Ch 1 Marker Life	43089	3	N/A	Binary
Ch 1 Filter Count	43090	3	N/A	Binary, 0 to 60
Ch 1 Radio Reg	43091	3	N/A	Binary
Ch 1 Coefficient	43092	3	N/A	Binary
Ch 1 Bridge Voltage	43093	3	N/A	Modbus 32 bit IEEE 754 Floating Pt
Ch 1 Balance	43095	3	N/A	Binary
Ch 1 Heater Enable	43096	3	N/A	False = NO, True = YES
Ch 1 Heater Setpoint	43097	3	N/A	Modbus 32 bit IEEE 754 Floating Pt
Ch 1 Temp Comp -40	43099	3	N/A	32 bit FP Gain, 32 bit FP Offset
Ch 1 Temp Comp -30	43103	3	N/A	32 bit FP Gain, 32 bit FP Offset
Ch 1 Temp Comp -20	43107	3	N/A	32 bit FP Gain, 32 bit FP Offset
Ch 1 Temp Comp -10	43111	3	N/A	32 bit FP Gain, 32 bit FP Offset
Ch 1 Temp Comp 0	43115	3	N/A	32 bit FP Gain, 32 bit FP Offset
Ch 1 Temp Comp +10	43119	3	N/A	32 bit FP Gain, 32 bit FP Offset
Ch 1 Temp Comp +20	43123	3	N/A	32 bit FP Gain, 32 bit FP Offset
Ch 1 Temp Comp +30	43127	3	N/A	32 bit FP Gain, 32 bit FP Offset
Ch 1 Temp Comp +40	43131	3	N/A	32 bit FP Gain, 32 bit FP Offset
Ch 1 Temp Comp +50	43135	3	N/A	32 bit FP Gain, 32 bit FP Offset
Ch 1 Temp Comp +60	43139	3	N/A	32 bit FP Gain, 32 bit FP Offset
Ch 1 Sensor Type	43143	3	N/A	TBD
Ch 1 Send Sensor Life	43144	3	N/A	False = NO, True = YES
Ch 1 Cal mA Setting	43145	3	N/A	Modbus 32 bit IEEE 754 Floating Pt
Ch 1 Local Cal	43147	3	N/A	False = NO, True = YES
Ch 1 AI Range	43148	3	N/A	TBD

Ch 2 Alarm 1 Latch	43201	3	N/A	False = NO, True = YES
Ch 2 Alarm 1 Trip	43202	3	N/A	False = HIGH, True = LOW
Ch 2 Alarm 1 On Delay	43203	3	N/A	Activation delay in seconds
Ch 2 Alarm 1 Off Delay	43204	3	N/A	Deactivation delay in minutes
Ch 2 Alarm 1 Hysteresis	43205	3	N/A	Percent of scale
Ch 2 Alarm 2 Latch	43211	3	N/A	False = NO, True = YES
Ch 2 Alarm 2 Trip	43212	3	N/A	False = HIGH, True = LOW
Ch 2 Alarm 2 On Delay	43213	3	N/A	Activation delay in seconds
Ch 2 Alarm 2 Off Delay	43214	3	N/A	Deactivation delay in minutes
Ch 2 Alarm 2 Hysteresis	43215	3	N/A	Percent of scale
Ch 2 Alarm 2 Color	43216	3	N/A	TBD
Ch 2 Alarm 3 Latch	43221	3	N/A	False = NO, True = YES
Ch 2 Alarm 3 Trip	43222	3	N/A	False = HIGH, True = LOW
Ch 2 Alarm 3 On Delay	43223	3	N/A	Activation delay in seconds
Ch 2 Alarm 3 Off Delay	43224	3	N/A	Deactivation delay in minutes
Ch 2 Alarm 3 Hysteresis	43225	3	N/A	Percent of scale
Ch 2 Alarm 3 Color	43226	3	N/A	TBD
Ch 2 Alarm 3 Enabled	43227	3	N/A	False = NO, True = YES
Ch 2 Data From	43231	3	N/A	Selection
Ch 2 Min Raw	43232	3	N/A	Binary (800)
Ch 2 Max Raw	43233	3	N/A	Binary (4000)
Ch 2 Remote ID	43234	3	N/A	Binary
Ch 2 Interface	43235	3	N/A	Binary
Ch 2 Byte Order	43236	3	N/A	Byte order
Ch 2 Alias	43237	3	N/A	Binary, 32 bit, 2x
Ch 2 IP Address	43239	3	N/A	Binary, 4x unsigned bytes
Ch 2 Port	43241	3	N/A	Binary, 32 bit, 2x
Ch 2 Remote Sensor	43243	3	N/A	Binary
Ch 2 DP	43279	3	N/A	Number of decimal points
Ch 2 Enable	43280	3	N/A	False = NO, True = YES
Ch 2 Deadband	43281	3	N/A	Modbus 32 bit IEEE 754 Floating Pt
Ch 2 Marker Enable	43283	3	N/A	False = NO, True = YES
Ch 2 Marker Percent	43284	3	N/A	Modbus 32 bit IEEE 754 Floating Pt
Ch 2 Marker Info	43286	3	N/A	6 ASCII characters
Ch 2 Marker Life	43289	3	N/A	Binary
Ch 2 Filter Count	43290	3	N/A	Binary, 0 to 60
Ch 2 Radio Reg	43291	3	N/A	Binary
Ch 2 Coefficient	43292	3	N/A	Binary
Ch 2 Bridge Voltage	43293	3	N/A	Modbus 32 bit IEEE 754 Floating Pt

GASMAX CX Operation & Maintenance Manual, Revision 1.0

Ch 2 Balance	43295	3	N/A	Binary
Ch 2 Heater Enable	43296	3	N/A	False = NO, True = YES
Ch 2 Heater Setpoint	43297	3	N/A	Modbus 32 bit IEEE 754 Floating Pt
Ch 2 Temp Comp -40	43299	3	N/A	32 bit FP Gain, 32 bit FP Offset
Ch 2 Temp Comp -30	43303	3	N/A	32 bit FP Gain, 32 bit FP Offset
Ch 2 Temp Comp -20	43307	3	N/A	32 bit FP Gain, 32 bit FP Offset
Ch 2 Temp Comp -10	43311	3	N/A	32 bit FP Gain, 32 bit FP Offset
Ch 2 Temp Comp 0	43315	3	N/A	32 bit FP Gain, 32 bit FP Offset
Ch 2 Temp Comp +10	43319	3	N/A	32 bit FP Gain, 32 bit FP Offset
Ch 2 Temp Comp +20	43323	3	N/A	32 bit FP Gain, 32 bit FP Offset
Ch 2 Temp Comp +30	43327	3	N/A	32 bit FP Gain, 32 bit FP Offset
Ch 2 Temp Comp +40	43331	3	N/A	32 bit FP Gain, 32 bit FP Offset
Ch 2 Temp Comp +50	43335	3	N/A	32 bit FP Gain, 32 bit FP Offset
Ch 2 Temp Comp +60	43339	3	N/A	32 bit FP Gain, 32 bit FP Offset
Ch 2 Sensor Type	43343	3	N/A	TBD
Ch 2 Send Sensor Life	43344	3	N/A	False = NO, True = YES
Ch 2 Cal mA Setting	43345	3	N/A	Modbus 32 bit IEEE 754 Floating Pt
Ch 2 Local Cal	43347	3	N/A	False = NO, True = YES
Ch 2 AI Range	43348	3	N/A	TBD
				Registers 45001-45022 added in V1.03
Ch 1 Value	45001	3	N/A	800 = "0", 4000 = Full Scale
Ch 2 Value	45002	3	N/A	800 = "0", 4000 = Full Scale
Ch 1 Value	45003/04	3	N/A	MODBUS 32 bit floating point
Ch 2 Value	45005/06	3	N/A	MODBUS 32 bit floating point
Ch 1 Alarm 1 Status	45007	3	N/A	"1" = Fault
Ch 1 Alarm 2 Status	45008	3	N/A	"1" = Fault
Ch 1 Alarm 3 Status	45009	3	N/A	"1" = Fault
Ch 1 Fault Status	45010	3	N/A	"1" = Fault
Ch 2 Alarm 1 Status	45011	3	N/A	"1" = Fault
Ch 2 Alarm 2 Status	45012	3	N/A	"1" = Fault
Ch 2 Alarm 3 Status	45013	3	N/A	"1" = Fault
Ch 2 Fault Status	45014	3	N/A	"1" = Fault
Ch 1 Sensor Life	45015	3	N/A	0-100 binary
Ch 2 Sensor Life	45016	3	N/A	0-100 binary
Ch 1 Sensor Temp	45017	3	N/A	Binary 0 - 4095
Ch2 Sensor Temp	45018	3	N/A	Binary 0 - 4095
Ch 1 Sensor Temp	45019/20	3	N/A	MODBUS 32 bit floating point
Ch 2 Sensor Temp	45021/22	3	N/A	MODBUS 32 bit floating point

12 SPARE PARTS

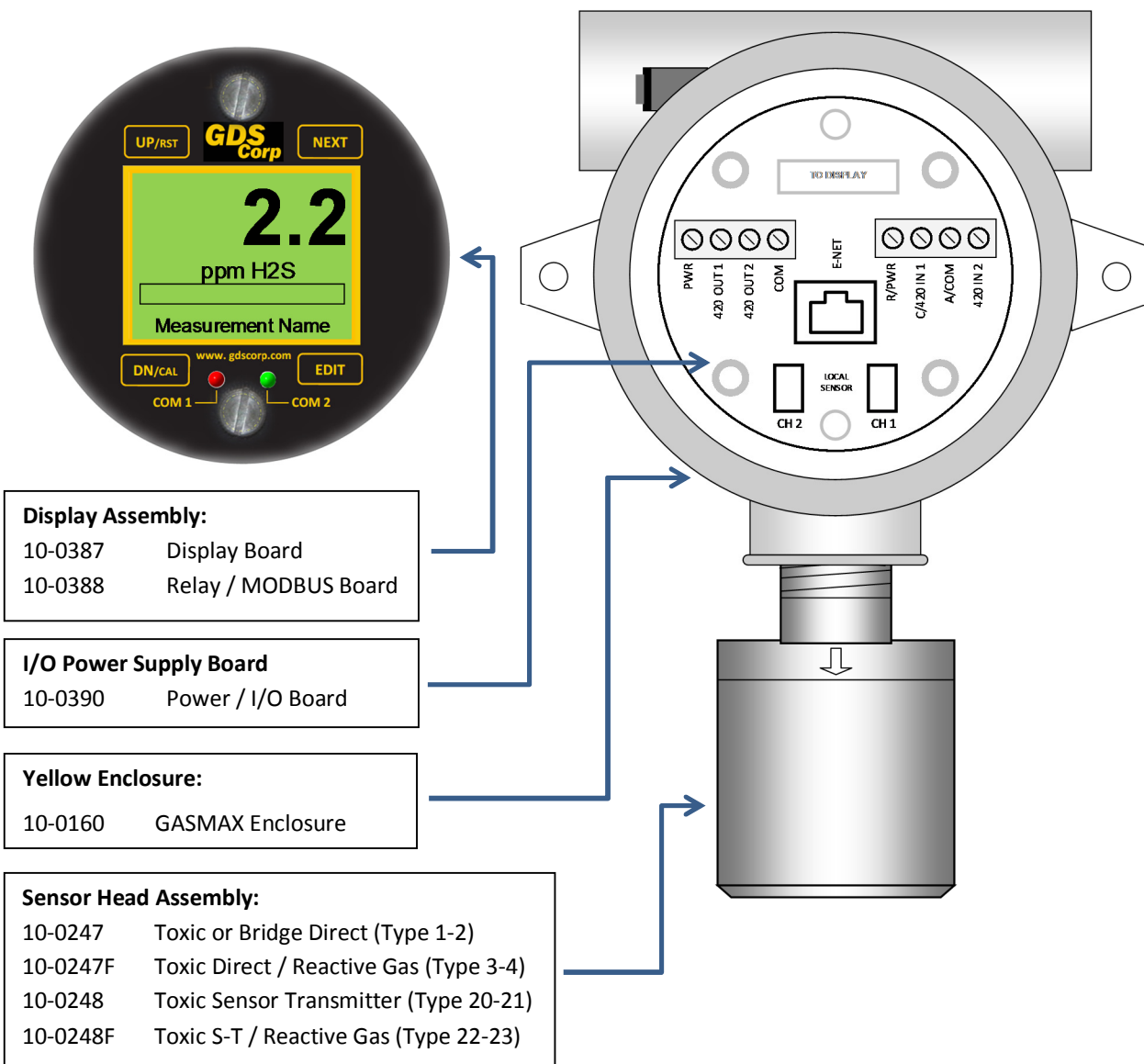

Figure 12-1: GASMAX CX + Local Sensor Spare Parts

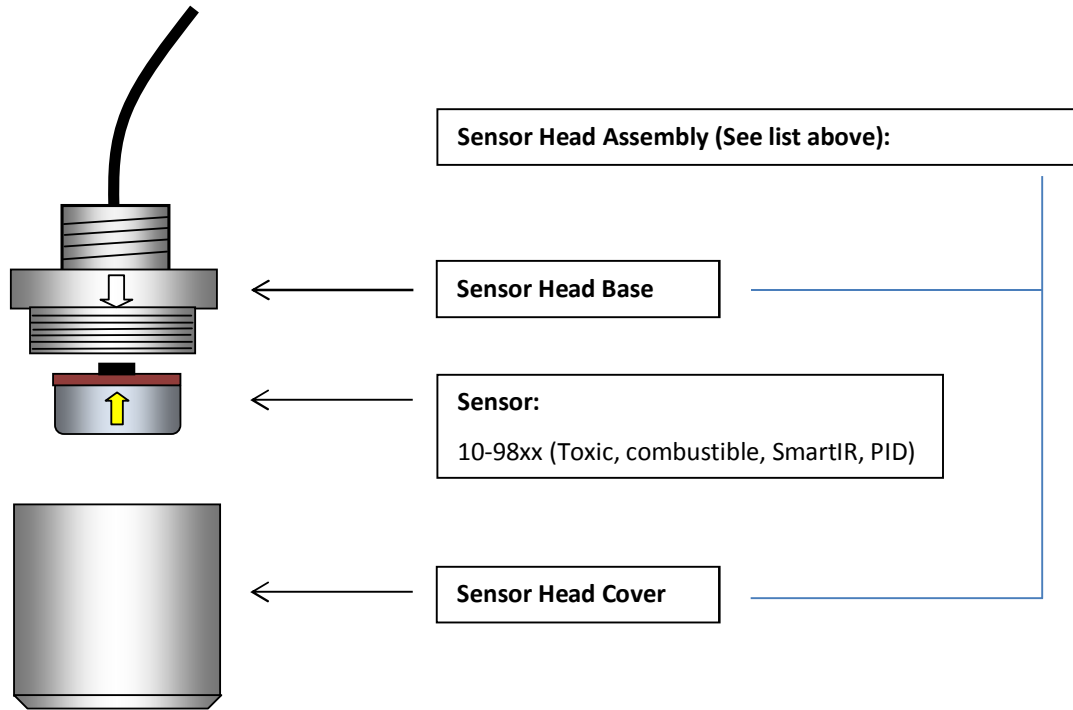

Figure 12-2: GASMAX Sensor Head

SENSOR HEAD ACCESSORIES

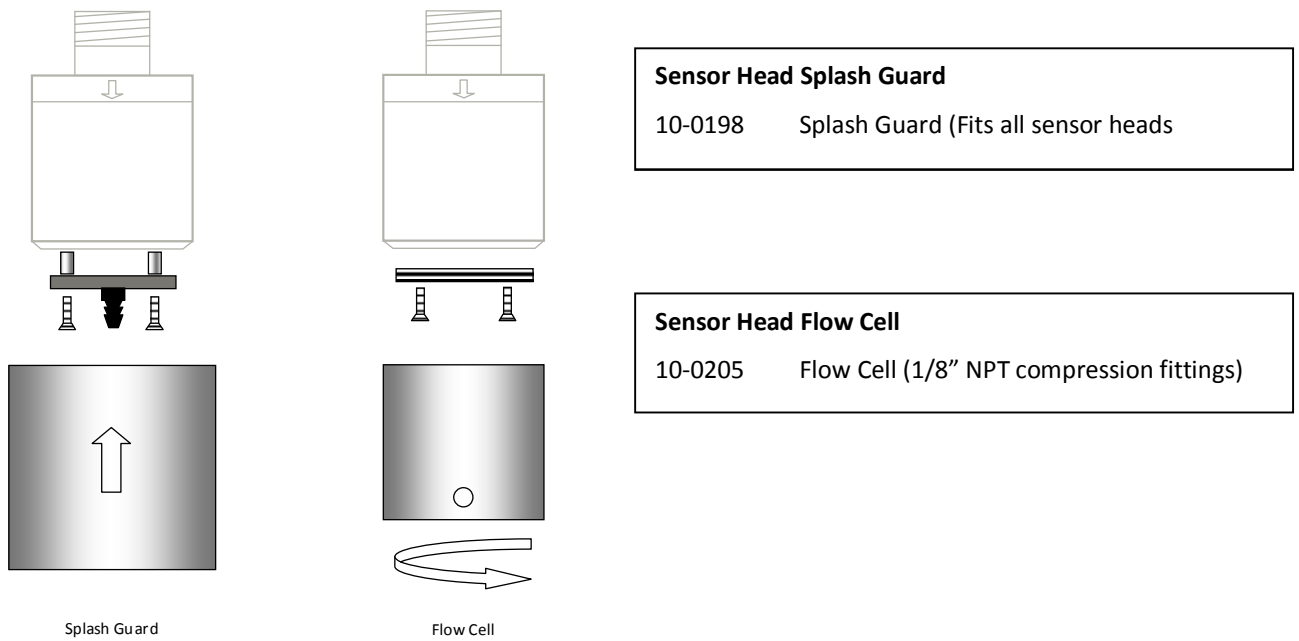

Figure 12-3: GASMAX Sensor Head Splash Guard & Flow Cell

13 DRAWINGS AND DIMENSIONS

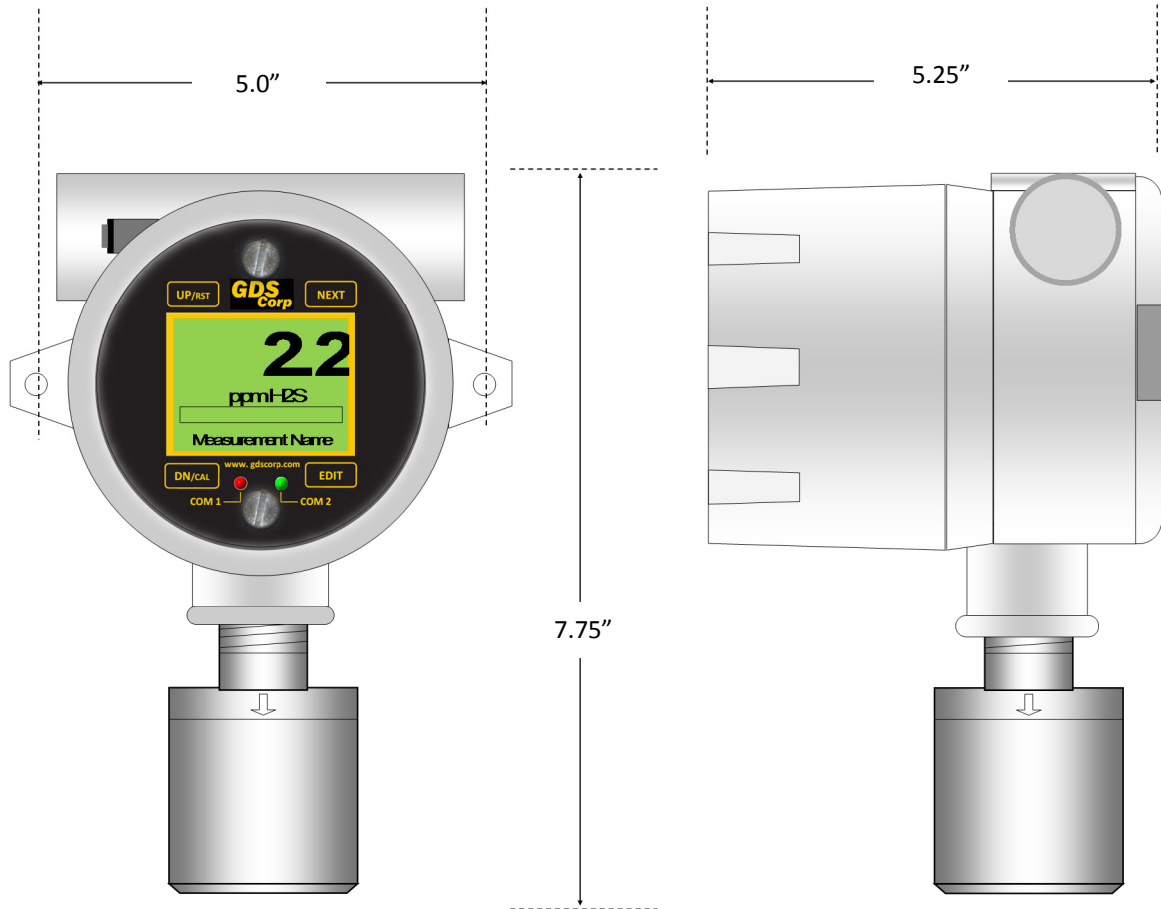

Figure 13-1 GASMAX CX DIMENSIONS

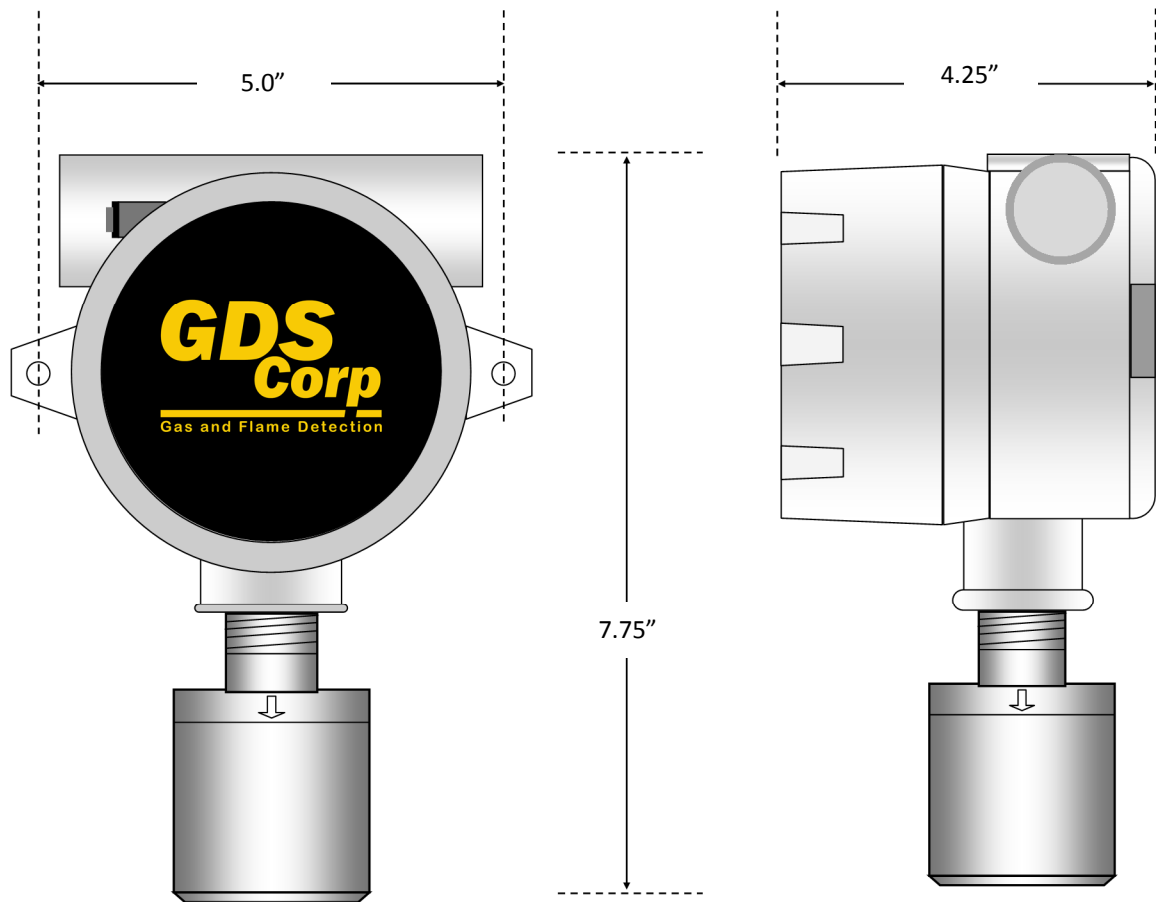

Figure 13-2 GASMAX CX REMOTE SENSOR TRANSMITTER DIMENSIONS