



Gas and Flame Detection

# Operation and Maintenance Manual

---

GDS-50 Remote Infrared Sensor Transmitter for Combustibles & CO<sub>2</sub>

---

GDS Corp.  
2513 Hwy 646 • Santa Fe, Texas 77510  
409-927-2980 • 409-927-4180 (Fax) • [www.gdscorp.com](http://www.gdscorp.com)

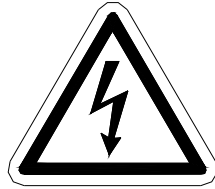

**CAUTION: FOR SAFETY REASONS THIS EQUIPMENT MUST BE OPERATED AND SERVICED BY QUALIFIED PERSONNEL ONLY. READ AND UNDERSTAND INSTRUCTION MANUAL COMPLETELY BEFORE OPERATING OR SERVICING.**

**ATTENTION: POUR DES RAISONS DE SÉCURITÉ, CET ÉQUIPEMENT DOIT ÊTRE UTILISÉ, ENTRETENU ET RÉPARÉ UNIQUEMENT PAR UN PERSONNEL QUALIFIÉ. ÉTUDIER LE MANUE D'INSTRUCTIONS EN ENTIER AVANT D'UTILISER, D'ENTRETENIR OU DE RÉPARER L'ÉQUIPEMENT.**

REVISION HISTORY

Revision 1.0    5/1/13    First release

---

Copyright © 2013 GDS Corp. All Rights Reserved

P/N 1200-0734-01

## Table of Contents

<b>1</b>	<b>SAFETY INFORMATION</b> .....	<b>4</b>
	WARNINGS.....	4
<b>2</b>	<b>GENERAL INFORMATION</b> .....	<b>5</b>
	INFRARED SENSORS .....	5
<b>3</b>	<b>SPECIFICATIONS</b> .....	<b>6</b>
<b>4</b>	<b>INSTALLATION</b> .....	<b>8</b>
	CHOOSING A LOCATION .....	8
	ELECTRICAL CONNECTIONS .....	9
<b>5</b>	<b>CALIBRATION</b> .....	<b>10</b>
	CALIBRATION OVERVIEW.....	10
	GENERALIZED CALIBRATION PROCEDURE .....	10
<b>6</b>	<b>OPERATION AND MAINTENANCE</b> .....	<b>12</b>
	SENSOR REPLACEMENT .....	12
<b>7</b>	<b>SPARE PARTS</b> .....	<b>14</b>
<b>8</b>	<b>DRAWINGS AND DIMENSIONS</b> .....	<b>15</b>

## List of Figures

Figure 3-1: Sensor Types.....	7
Figure 4-1: GDS-50 Enclosure.....	8
Figure 4-2: GDS-50 Wiring Connections.....	9
Figure 5-1: Applying Calibration Gas to GDS-50.....	11
Figure 6-1: Sensor Replacement .....	13
Figure 8-1: GDS-50 Dimensions.....	15

# 1 SAFETY INFORMATION

## Important – Read Before Installation

Users should have a detailed understanding of GDS-50 operating and maintenance instructions. Use the GDS-50 only as specified in this manual or detection of gases and the resulting protection provided may be impaired. Read the following WARNINGS prior to use.

### **WARNINGS**

- The GDS-50 sensor transmitter described in this manual must be installed, operated and maintained in accordance with information contained herein. Installation in any hazardous area must comply with all applicable restrictions, requirements and guidelines for said hazardous areas. It is the end user customer's final decision to ensure that the GDS-50 is suitable for the intended use.
- The GDS-50 is designed and constructed to measure the level of certain gases in ambient air. Accuracy in atmospheres containing steam or inert gases cannot be guaranteed.
- Always mount the sensor head vertically with the sensor head facing down.
- Do not paint sensor assembly.
- Do not operate the GDS-50 if its enclosure is damaged or cracked or has missing components. Make sure the cover, internal PCB's and field wiring are securely in place before applying power.
- Do not expose the GDS-50 to electrical shock or continuous severe mechanical shock. Protect the GDS-50 and related sensor assemblies from dripping liquids and high power sprays.
- Calibrate with known target gas at start-up and check on a regular schedule, at least every 90 days. More frequent inspections are encouraged to spot problems such as dirt, oil, paint, grease or other foreign materials on the sensor head.
- Periodically test for correct operation of the system's alarm events by exposing the monitor to a targeted gas concentration above the High Alarm set point.
- Use only for applications described within this manual.

## 2 GENERAL INFORMATION

The GDS-50 Remote Infrared Sensor Transmitter is designed to measure combustible hydrocarbon gases including methane, propane, ethane, ethanol and many others, as well as both ppm level and percent-by-volume levels of carbon dioxide. The GDS-50 is ideally suited for installation where reliability and cost are critically important and where a local display is not required. The GDS-50 has the following key features:

- Standard 4 to 20 mA output (current source)
- High performance SmartIR infrared sensor with integrated IR source, dual channel receiver, temperature compensation and fault detection.
- Field-replaceable sensor element
- Remote fault indication for sensor fail or missing sensor (at controller)
- Powder-coated aluminum enclosure with 316 stainless steel sensor head
- Enclosure certified for use in Class I Division 1, Groups B, C & D hazardous areas

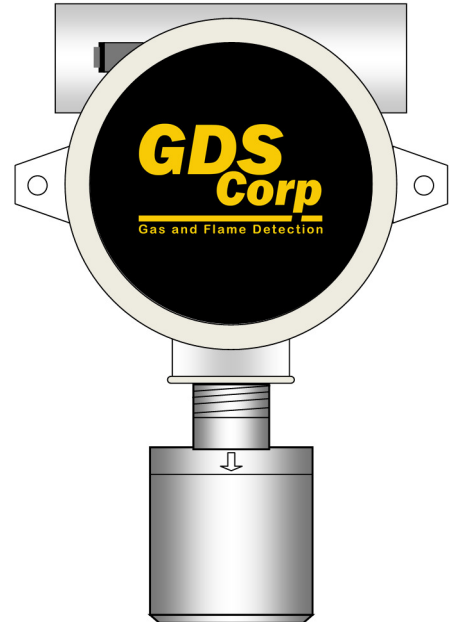

**NOTE: THE GDS-50 DOES NOT HAVE INTERNAL ZERO AND SPAN CALIBRATION ADJUSTMENTS AND MUST BE USED WITH A CONTROLLER THAT PROVIDES LOCAL CALIBRATION CAPABILITY. ALL GDS CORP CONTROLLERS OFFER THIS FEATURE.**

**INFRARED SENSORS** use an infrared light source to detect hydrocarbons. Carbon-hydrogen bonds in most common hydrocarbon molecules absorb certain frequencies of infrared light. As a result, when any hydrocarbon gas passes between the infrared source and detector, the detector output drops, indicating the presence of gas. A reference beam that is not affected by H-C bonds is used to monitor changes in source intensity and eliminate false alarms. GDS Corp SmartIR infrared sensors contain fully integrated source, receiver and microprocessor-based circuitry to perform this function.

### 3 SPECIFICATIONS

Model:	GDS Corp GDS-50 Remote Infrared Sensor Transmitter for Combustible Gases and Carbon Dioxide
Power Input:	4-20mA current output; power consumption less than 2.0 watts max in over-range condition.
Display:	None
Sensor:	Type 10-96xx direct connect voltage output SmartIR infrared sensors for combustible and carbon dioxide.
Accuracy:	$\pm 2\%$ full scale @ 20°C (68°F), 1 bar pressure, applied gas; 2.5% volume methane
Repeatability:	Zero: $\pm 1\%$ full scale at 20°C ambient Span: $\pm 2\%$ full scale at 20°C ambient
Temperature Performance:	$\pm 10\%$ of reading up to 50% full scale, $\pm 15\%$ of reading from 50% to 100% full scale, or 2% full scale whichever is greater over the range -20°C to +50°C (-4°F to 122°F)
Long Term Zero Drift:	$\pm 1\%$ full scale per month @ 20°C (68°F) ambient, (max $\pm 3\%$ full scale per year)
Calibration:	Output is factory adjusted but is not calibrated. Receiving device must provide zero and span (two-point) calibration. The GDS-50 is compatible with all GDS Corp controllers with bridge-style inputs that provide two-point calibration capability.
Warm-up Time:	Sensor warm-up to final zero $\pm 2\%$ full scale in one minute at 20°C ambient. GDS Corp recommends a one hour warm-up before attempting final calibration
Output:	Uncalibrated 4-20mA (current source). Maximum loop resistance is 600 ohms with nominal 24V power supply.
Response Time:	Less than 30 seconds ( $T_{90}$ ) at 20°C ambient Less than 10 seconds ( $T_{50}$ ) at 20°C ambient
Temperature:	-20°C to + 50°C operating
Fault Indication:	Zero volt output for sensor fail or sensor missing
Housing:	Junction box epoxy-coated aluminum, sensor head 316 stainless steel.
Approvals:	Enclosure CSA certified for use in Class 1, Division 1, Groups B, C and D Explosion Proof area.
Warranty:	Two years on electronics, one year on sensor

Sensor	Target Gas	Range	% by volume	Comments
50	Methane	0-100 % LEL	0 – 5%	Fully characterized over temp range
51	Propane	0-100% LEL	0 – 2%	Fully characterized over temp range
52	Methane	0-100% v/v	0 – 100%	Fully characterized over temp range
53	Carbon Dioxide	Multiple Ranges	Multiple Ranges	Range 0-2000 ppm to 0-100% v/v
54	Propylene	0-100% LEL	0 – 2%	Fully characterized over temp range
55	Butane	0-100% LEL	0 – 2%	Fully characterized over temp range
56	Pentane	0-100% LEL	0 – 2%	Fully characterized over temp range
57	Ethylene Oxide	0-100% LEL	0 – 3%	Fully characterized over temp range
58	Ethane	0-100% LEL	0 – 3%	Fully characterized over temp range
59	Hexane	0-100% LEL	N/A	Output linearized for hexane
5A	Acetone	0-100% LEL	N/A	Response factor based on propane
5B	Ethane	0-100% LEL	0 – 3%	Fully characterized over temp range
5C	Ethanol	0-100% LEL	N/A	Response linearized for ethanol
5X	Specify Gas	TBE	-20°C to + 50°C	Contact Factory

**Figure 3-1: Sensor Types**

## 4 INSTALLATION

### CHOOSING A LOCATION

Factors such as air movement, gas density, emission sources and environmental variables affect sensor location. Air movement by fans, prevailing winds and convection should be carefully evaluated to determine if a leak is more likely to raise gas levels in certain areas within the facility. Vapor density of a gas determines if it will rise or fall in air when there are no significant currents. Lighter than air gases should have the monitors mounted 12 – 18 inches (30 – 45 cm) above the potential gas leak and heavier than air gases should be this distance below. Even though the GDS-50 sensor transmitter is designed for rugged service, it should be protected from environmental damage due to water, snow, shock, vibration or dust / dirt.

The GDS-50 should always be mounted with the sensor head opening facing down. If necessary, a Splash Guard (p/n 10-0198) should be attached if there is any chance that water or liquid spray could enter the sensor opening from below. Be sure to leave sufficient room (~ 12") below the sensor head to allow easy access for attachment of a Calibration Cup and / or removal of the sensor head cover for sensor replacement.

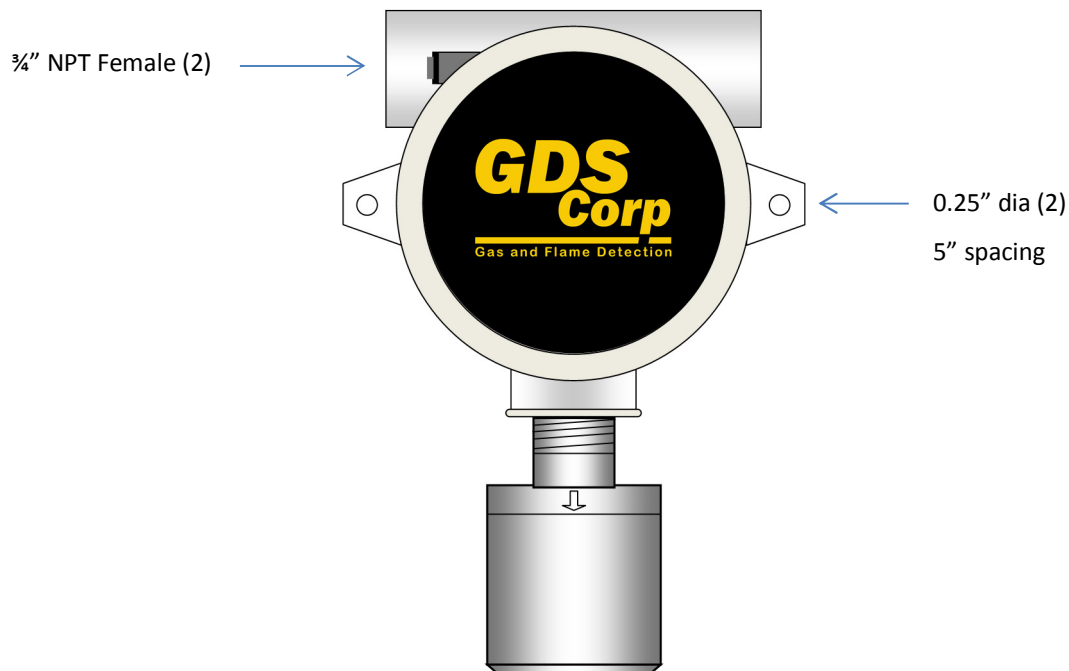
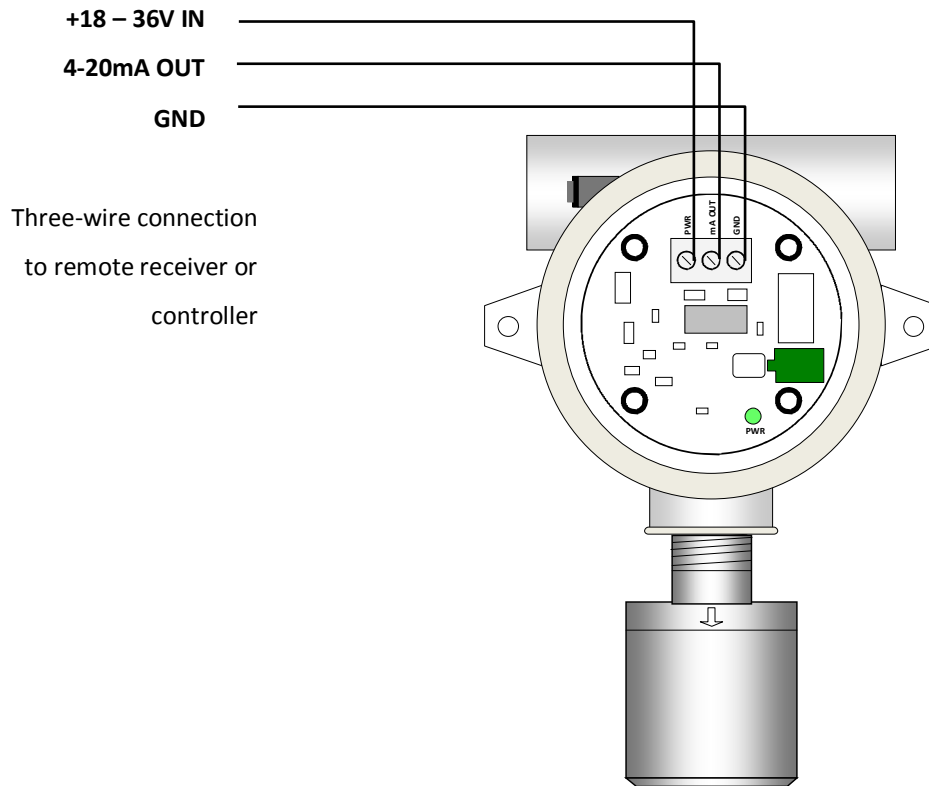

Figure 4-1: GDS-50 Enclosure



## ELECTRICAL CONNECTIONS

The GDS-50 is a three-wire 4-20mA output sensor that requires +24V and outputs an uncalibrated 4-20mA signal to the remote controller or receiver. Incorrect wiring can result in sensor damage or failure.



**Figure 4-2: GDS-50 Wiring Connections**

Shielded cable is always recommended and should never be run in conduit with high voltage AC power wiring.

When power is initially applied to the GDS-50 the output may momentarily indicate a temporary off-scale low (FAULT) or off-scale high (OVERRANGE) value before settling down. All GDS Corp controllers provide a 'warm up' interval during which the sensor input is ignored. This keeps the controller from indicating an alarm due to sensor warm-up characteristics.

Total warm-up time is dependent on the type of sensor and range selected. GDS Corp recommends a four to eight hour interval between initial power-on and first calibration. If the sensor has been powered up, and has only been offline for a few hours, the warm-up time will be shorter.

## 5 CALIBRATION

### CALIBRATION OVERVIEW

The GDS-50 does not have the capability to perform zero and span calibration. Final zero and span calibration must be performed by the controller or receiving device.

Follow these GDS-50 calibration guidelines:

- Calibration accuracy is only as good as the calibration gas accuracy. GDS Corp calibration gases are traceable to NIST (National Institute of Standards and Technology).
- **Never use calibration gas that has passed its expiration date.**
- Always use a GDS Corp calibration cup that completely surrounds the sensor head.
- Be sure to use ZERO AIR, a mixture of 21% oxygen and 79% nitrogen, as a zero reference unless you are certain that no target gas exists in the area. Ambient gas may result in an 'elevated zero' condition that will cause a FAULT to occur once the ambient gas is no longer present.
- GDS Corp recommends using a span gas that is between 25% and 75% of full scale. GDS Corp does not recommend using full scale as the span set point.
- **Always calibrate a new sensor before depending on the device for personnel or equipment safety**
- Calibrate on a regular schedule. GDS Corp recommends a full calibration every 3 months, with periodic 'bump tests' on a more frequent basis to ensure that the sensor has not been affected by temperature extremes or the presence of incompatible gases.

In general, calibration involves applying a zero reference gas and telling the receiving device to accept that output as 'zero', followed by the application of a span reference gas and then telling the receiving device to accept the new output as 'span' once the output has stabilized. This is generally performed by two persons, one at the sensor transmitter and one at the receiving device. Actual procedures, time intervals and techniques for indicating zero and span values depend on the specific receiving device. All GDS Corp display and alarm controllers provide the necessary local calibration capability.

### GENERALIZED CALIBRATION PROCEDURE

Before beginning calibration, make sure you have the following items: A cylinder of calibration gas, fixed flow regulator and an appropriate calibration cup connected to the regulator via a length of flexible tubing. If necessary, a cylinder of 'zero air' may be necessary if the absence of target gas cannot be confirmed. GDS Corp recommends a flow rate of 0.5 liters / minute.

In the case of PID sensors, it may be desired to substitute a surrogate gas for the target gas, especially if the target gas is dangerous or unavailable in a calibration gas cylinder. For more information on surrogate gases and relative response factors for common volatile organic compounds, contact GDS Corp for a list of available gases and response factors.

The actual steps involved in calibration vary depending on the receiving device, but can be generalized as follows:

1. Select the appropriate channel on the controller or receiver and enable Calibration Mode. This should disable alarms during the calibration process. Make sure that the controller's Cal Span value matches the cylinder of calibration gas.
2. Apply zero air to the sensor as shown in Fig. 6-1 or confirm the absence of any target gas.
3. At the controller or receiver, press the "Set Zero" button to confirm that the current reading is 'zero'.
4. Apply span gas to the sensor as shown in Fig 6-1.
5. At the controller or receiver, monitor the output until it stabilizes. When stable, press the "Set Span" button to confirm that the current reading corresponds to the Span value.
6. Turn off the regulator and remote the calibration cup from the sensor head.
7. At the controller or receiver, exit Cal Mode and resume normal operation.

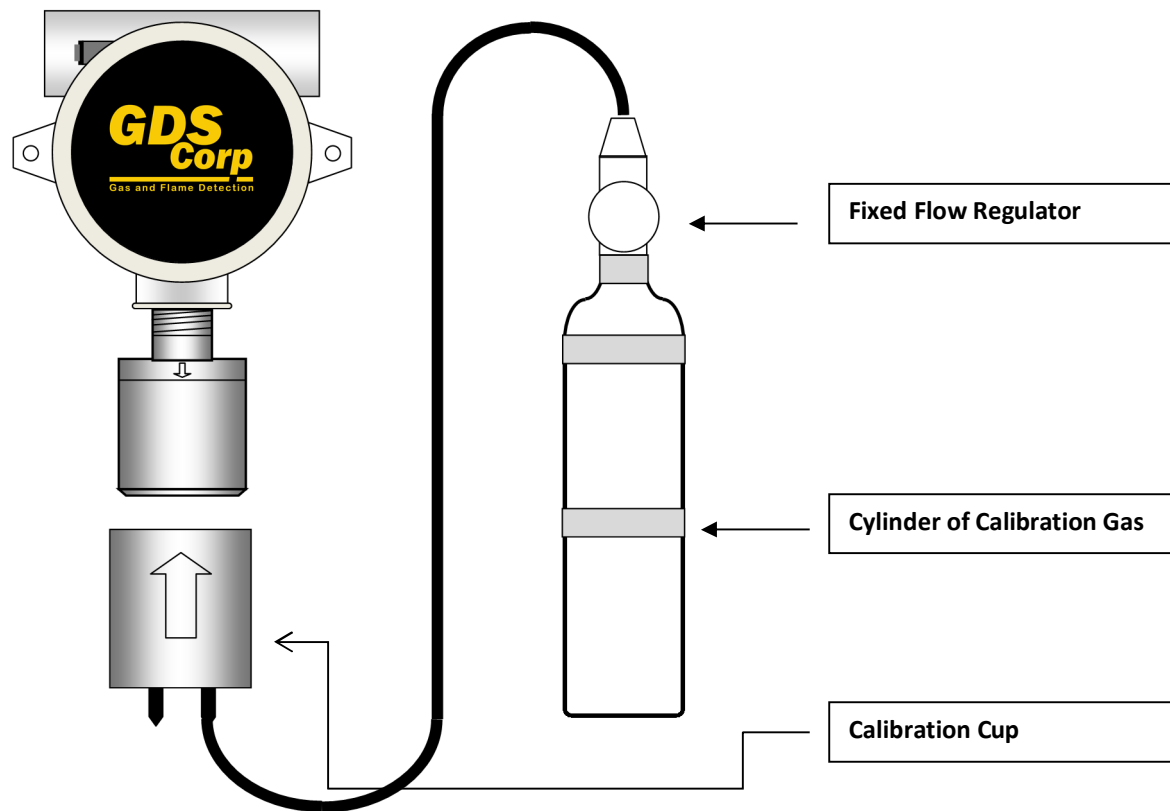

**Figure 5-1: Applying Calibration Gas to GDS-50**

## 6 OPERATION AND MAINTENANCE

In the normal operating mode, the 4-20mA output corresponds to the detected gas concentration. In the event of a significant gas release, the GDS-50 will indicate an overrange condition if the sensor's output continues to increase beyond the full scale value. In the event that the sensor output drops below zero due to interference gases or sensor failure, the output will drop to zero, indicating a FAULT condition to the remote receiver or controller. If the sensor is removed, the output will also drop to zero.

The GDS-50 should be checked regularly for damage, water ingress or flame arrestor clogging due to excessive dust or dirt. If the flame arrestor has become contaminated by dust, dirt or moisture, remove the sensor head cover (after first making sure to declassify the area) and carefully clean with compressed air. Use of solvent is discouraged as remnants of the solvent material may affect the sensor. There are no user-serviceable components and maintenance is limited to cleaning and/or sensor replacement.

Some GDS Corp controllers and gas detectors monitor 'sensor life' by calculating a value between 0 and 100% based on the current response to calibration gas as compared to the initial response when the sensor was first installed. To ensure that the calculations are accurate, please make certain to follow the 'new sensor' installation instructions in the appropriate device manual.

### SENSOR REPLACEMENT

If a sensor shows FAULT, does not respond to gas or can no longer be calibrated, it should be replaced. GDS-50 sensor transmitters use GDS Corp type 10-96XX sensors, where the XX is the gas type shown in Section 3. The range value should also be specified when ordering replacement sensors. For example, a replacement SmartIR infrared for methane, 0-100% LEL would be "10-9650-R0100".

To replace a sensor, review Fig. 6-1 and follow these steps:

1. Declassify the area or remove power to the GDS-50.
2. Unscrew the sensor head cover. If unable to open the cover by hand, use a Sensor Head Replacement Tool (p/n 10-0187).
3. Remove the old sensor by pulling straight down.

**NOTE: PULL STRAIGHT DOWN. DO NOT TRY TO UNSCREW THE SENSOR.**

4. Carefully install the replacement sensor by aligning the arrow on the sensor with the arrow engraved on the sensor head. Push straight up until the sensor connector seats firmly into the sensor connector.

5. Reinstall the sensor head cover by CAREFULLY screwing the cover onto the sensor head.

**NOTE: IF THE SENSOR FALLS OUT OF THE SENSOR HEAD DURING THIS STEP, IT CAN BE DAMAGED. USE CAUTION WHEN REINSTALLING THE SENSOR HEAD COVER.**

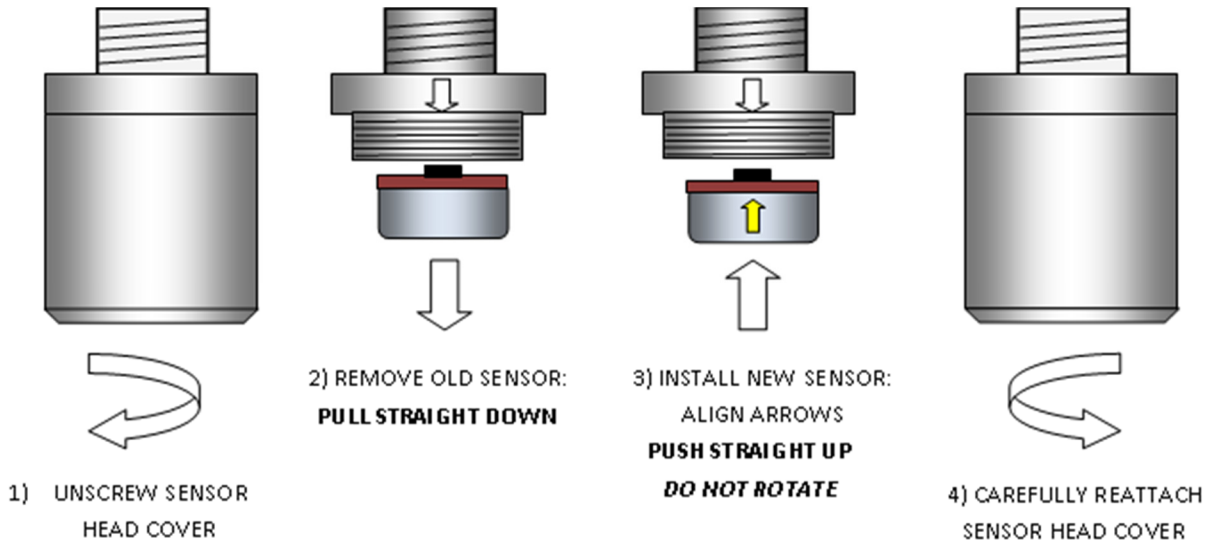

**Figure 6-1: Sensor Replacement**

## 7 SPARE PARTS

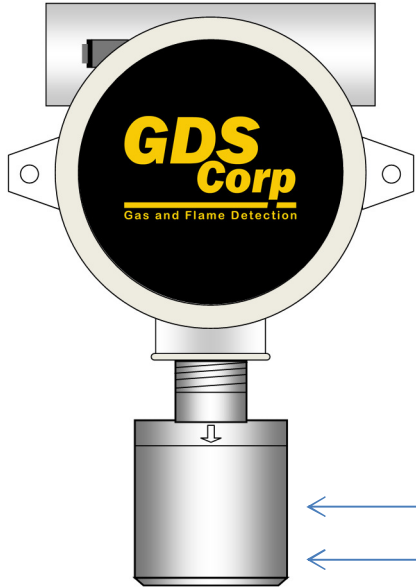

- Enclosure:**  
 12-0099 Enclosure, yellow, solid cover  
 20-0097 Sensor interface PCB assembly

- Sensor Head:**  
 10-0247 Stainless steel sensor head  
 Note: Does not include sensor

- Sensor:**  
 10-96xx GDS Corp SmartIR (V) Sensor

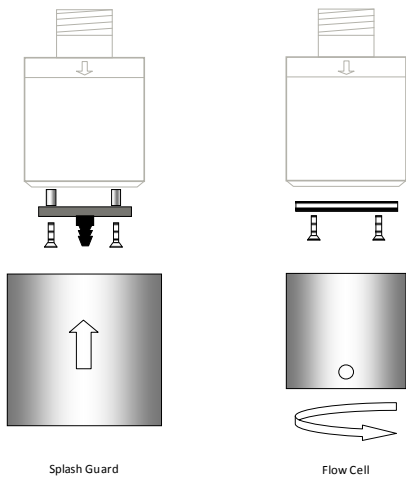

- Sensor Head Splash Guard**  
 10-0198 Splash Guard (Fits all sensor heads)

- Sensor Head Flow Cell**  
 10-0205 Flow Cell (1/8" NPT compression fittings)  
 20-02055 Other (specify)

## 8 DRAWINGS AND DIMENSIONS

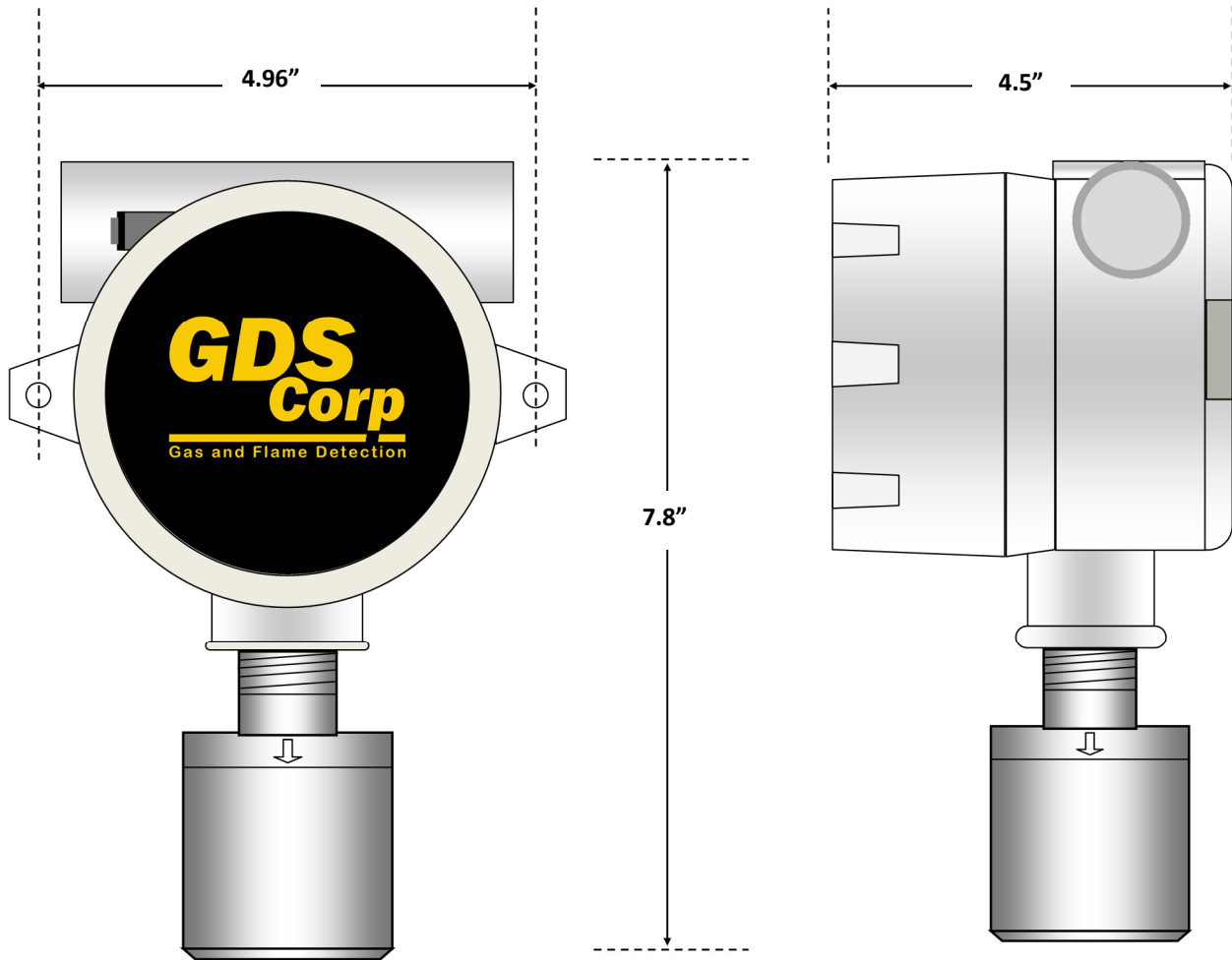

Figure 8-1: GDS-50 Dimensions