

Series CT260S

Standard Threaded Thermowells for 1/4" Elements (.260 Bore)

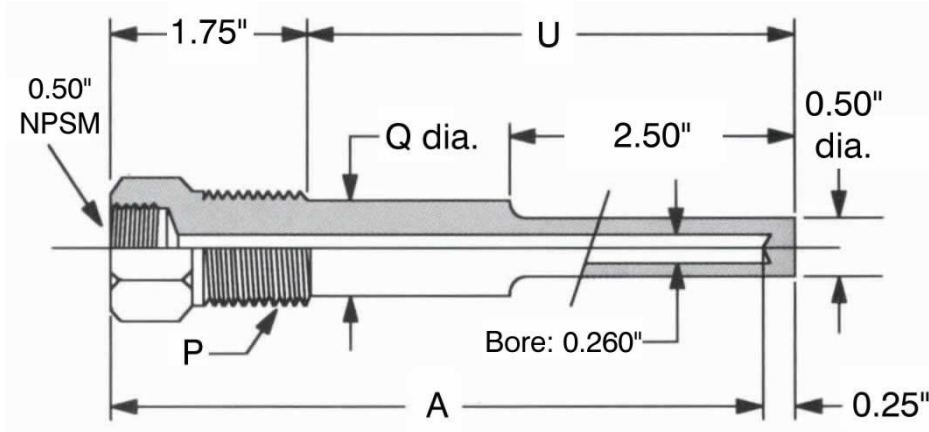

Notes:

1. Cap and chain available upon request.
 2. Special finishes are available upon request.
 3. Standard well is stepped to 1/2" OD except U=2 1/2"
- Please specify if straight shank is required.

External Thread P	Model #	Element Length A	Insert Length U	Shank Dia. Q	
1/2" NPT	1/2-260S	-U 2 1/2	4	2 1/2	1/2
		-U 4 1/2	6	4 1/2	5/8
		-U 7 1/2	9	7 1/2	5/8
		-U 10 1/2	12	10 1/2	5/8
		-U 13 1/2	15	13 1/2	5/8
		-U 16 1/2	18	16 1/2	5/8
		-U 22 1/2	24	22 1/2	5/8
3/4" NPT	3/4-260S	-U 2 1/2	4	2 1/2	1/2
		-U 4 1/2	6	4 1/2	3/4
		-U 7 1/2	9	7 1/2	3/4
		-U 10 1/2	12	10 1/2	3/4
		-U 13 1/2	15	13 1/2	3/4
		-U 16 1/2	18	16 1/2	3/4
		-U 22 1/2	24	22 1/2	3/4
1" NPT	1-260S	-U 2 1/2	4	2 1/2	3/4
		-U 4 1/2	6	4 1/2	7/8
		-U 7 1/2	9	7 1/2	7/8
		-U 10 1/2	12	10 1/2	7/8
		-U 13 1/2	15	13 1/2	7/8
		-U 16 1/2	18	16 1/2	7/8
		-U 22 1/2	24	22 1/2	7/8

Series CT260SL

Standard Threaded thermowells for 1/4" Elements (.260 Bore) w/ Lagging Extension

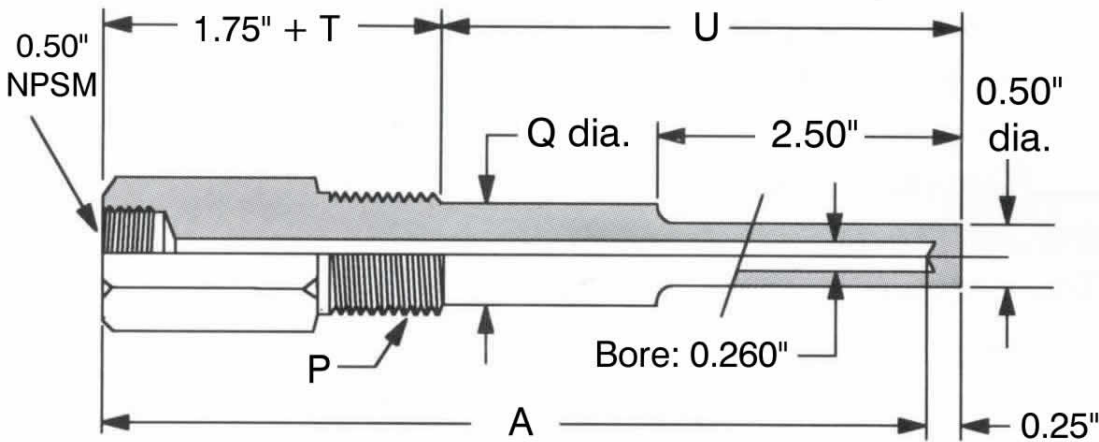

Notes:

1. Cap and chain available upon request.
2. Special finishes are available upon request.
3. Standard well is stepped to 1/2" OD except U=2 1/2"
- Please specify if straight shank is required.
4. Additional lagging extensions are available upon request.

External Thread P	Model #	Lag Ext. T	Element Length A	Insert Length U	Shank Dia. Q	
1/2" NPT	1/2-260SL	-U 2 1/2	2	6	2 1/2	1/2
		-U 4 1/2	3	9	4 1/2	5/8
		-U 7 1/2	3	12	7 1/2	5/8
		-U 10 1/2	3	15	10 1/2	5/8
		-U 13 1/2	3	18	13 1/2	5/8
		-U 19 1/2	3	24	19 1/2	5/8
3/4" NPT	3/4-260SL	-U 2 1/2	2	6	2 1/2	1/2
		-U 4 1/2	3	9	4 1/2	3/4
		-U 7 1/2	3	12	7 1/2	3/4
		-U 10 1/2	3	15	10 1/2	3/4
		-U 13 1/2	3	18	13 1/2	3/4
		-U 19 1/2	3	24	19 1/2	3/4
1" NPT	1-260SL	-U 2 1/2	2	6	2 1/2	3/4
		-U 4 1/2	3	9	4 1/2	7/8
		-U 7 1/2	3	12	7 1/2	7/8
		-U 10 1/2	3	15	10 1/2	7/8
		-U 13 1/2	3	18	13 1/2	7/8
		-U 19 1/2	3	24	19 1/2	7/8

Series CT385S

Standard Threaded Thermowells for 3/8" Elements (.385 Bore)

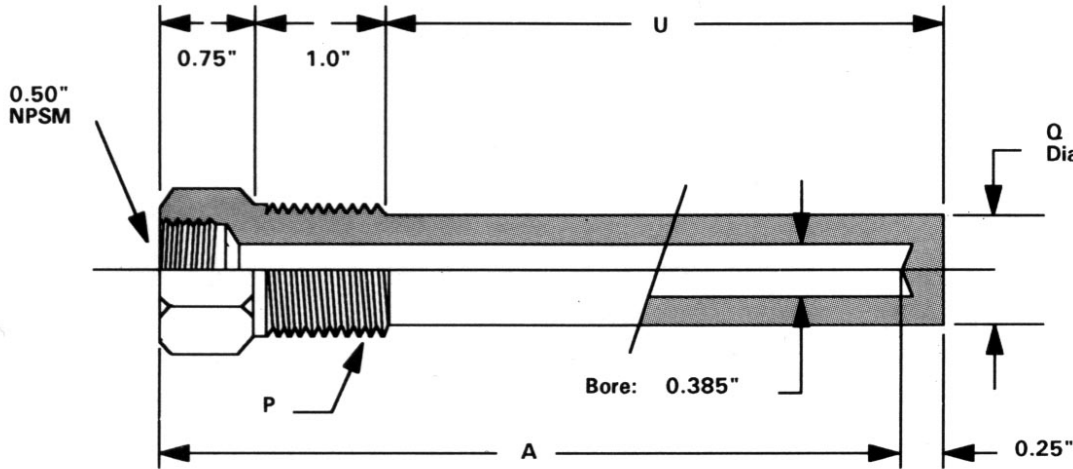

Notes:

1. Cap and chain available upon request.
2. Special finishes are available upon request.

External Thread P	Model #	Element Length A	Insert Length U	Shank Dia. Q	
3/4" NPT	3/4-385S	-U 2 1/2	4	2 1/2	49/64
		-U 4 1/2	6	4 1/2	49/64
		-U 7 1/2	9	7 1/2	49/64
		-U 10 1/2	12	10 1/2	49/64
		-U 13 1/2	15	13 1/2	49/64
		-U 16 1/2	18	16 1/2	49/64
		-U 22 1/2	24	22 1/2	49/64
1" NPT	1-385S	-U 2 1/2	4	2 1/2	7/8
		-U 4 1/2	6	4 1/2	7/8
		-U 7 1/2	9	7 1/2	7/8
		-U 10 1/2	12	10 1/2	7/8
		-U 13 1/2	15	13 1/2	7/8
		-U 16 1/2	18	16 1/2	7/8
		-U 22 1/2	24	22 1/2	7/8

Series CT385SL

Standard Threaded thermowells for 3/8" Elements (.385 Bore) w/ Lagging Extension

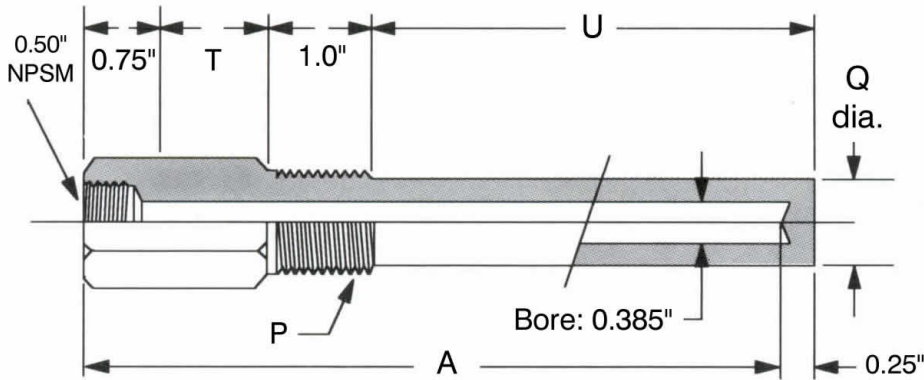

Notes:

1. Cap and chain available upon request.
2. Special finishes are available upon request.
3. Additional lagging extensions available upon request.

External Thread P	Model #	Lag Ext. T	Element Length A	Insert Length U	Shank Dia. Q
3/4" NPT	3/4-385SL	-U 2 1/2	6	2 1/2	49/64
		-U 4 1/2	9	4 1/2	49/64
		-U 7 1/2	12	7 1/2	49/64
		-U 10 1/2	15	10 1/2	49/64
		-U 13 1/2	18	13 1/2	49/64
		-U 19 1/2	24	19 1/2	49/64
1" NPT	1-385SL	-U 2 1/2	6	2 1/2	7/8
		-U 4 1/2	9	4 1/2	7/8
		-U 7 1/2	12	7 1/2	7/8
		-U 10 1/2	15	10 1/2	7/8
		-U 13 1/2	18	13 1/2	7/8
		-U 19 1/2	24	19 1/2	7/8

Series CT260HD

Threaded Heavy Duty Thermowell for 1/4" Elements (.260 Bore)

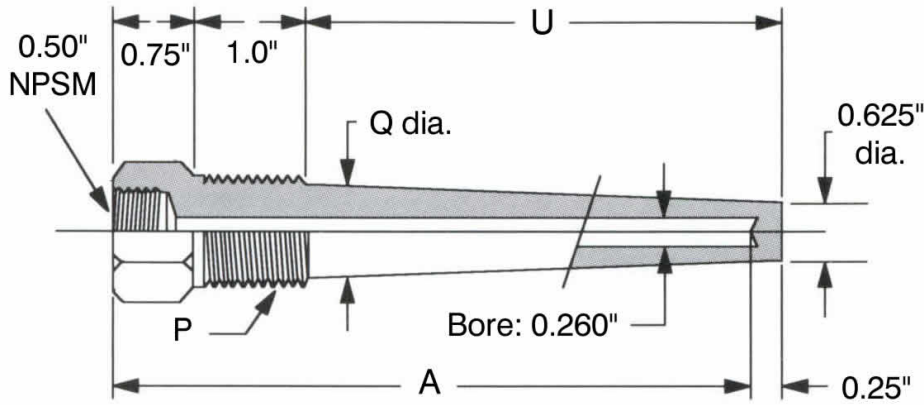

Notes:

- 1. Cap and chain available upon request.
- 2. Special finishes are available upon request.

External Thread P	Model #	Element Length A	Insert Length U	Shank Dia. Q
3/4" NPT	3/4-260HD	-U 2 1/2	2 1/2	7/8
		-U 4 1/2	4 1/2	7/8
		-U 7 1/2	7 1/2	7/8
		-U 10 1/2	10 1/2	7/8
		-U 13 1/2	13 1/2	7/8
		-U 16 1/2	16 1/2	7/8
		-U 22 1/2	22 1/2	7/8
1" NPT	1-260HD	-U 2 1/2	2 1/2	1 1/16
		-U 4 1/2	4 1/2	1 1/16
		-U 7 1/2	7 1/2	1 1/16
		-U 10 1/2	10 1/2	1 1/16
		-U 13 1/2	13 1/2	1 1/16
		-U 16 1/2	16 1/2	1 1/16
		-U 22 1/2	22 1/2	1 1/16

Series CT260HDL

Threaded Heavy Duty Thermowells for 1/4" Elements (.260 Bore) w/ Lagging Extension

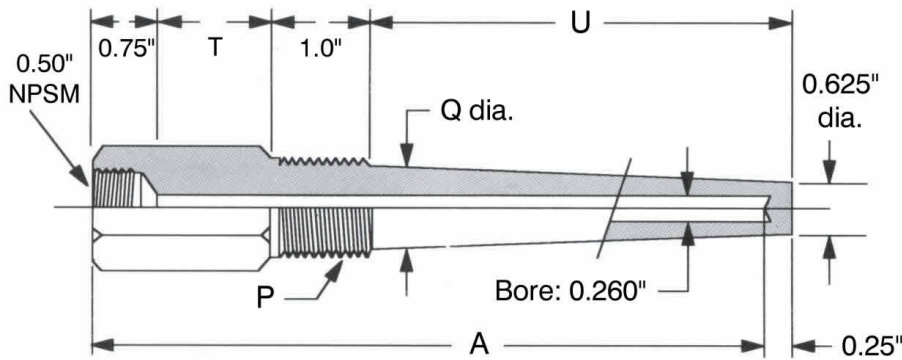

Notes:

1. Cap and chain available upon request.
2. Special finishes are available upon request.
3. Additional lagging extensions available upon request.

External Thread P	Model #	Lag Ext. T	Element Length A	Insert Length U	Shank Dia. Q	
3/4" NPT	3/4-260HDL	-U 2 1/2	2	6	2 1/2	7/8
		-U 4 1/2	3	9	4 1/2	7/8
		-U 7 1/2	3	12	7 1/2	7/8
		-U 10 1/2	3	15	10 1/2	7/8
		-U 13 1/2	3	18	13 1/2	7/8
		-U 19 1/2	3	24	19 1/2	7/8
1" NPT	1-260HDL	-U 2 1/2	2	6	2 1/2	1 1/16
		-U 4 1/2	3	9	4 1/2	1 1/16
		-U 7 1/2	3	12	7 1/2	1 1/16
		-U 10 1/2	3	15	10 1/2	1 1/16
		-U 13 1/2	3	18	13 1/2	1 1/16
		-U 19 1/2	3	24	19 1/2	1 1/16

Series CT385HD

Threaded Heavy Duty Thermowells for 3/8" Elements (.385 Bore)

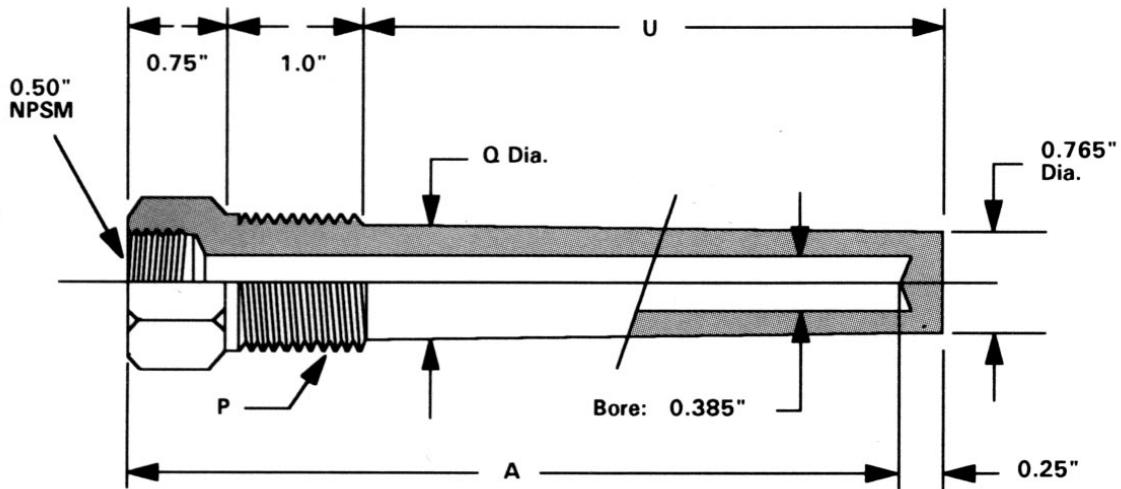

Notes:

1. Cap and chain available upon request.
2. Special finishes are available upon request.

External Thread P	Model #	Element Length A	Insert Length U	Shank Dia. Q	
3/4" NPT	3/4-385HD	-U 2 1/2	4	2 1/2	7/8
		-U 4 1/2	6	4 1/2	7/8
		-U 7 1/2	9	7 1/2	7/8
		-U 10 1/2	12	10 1/2	7/8
		-U 13 1/2	15	13 1/2	7/8
		-U 16 1/2	18	16 1/2	7/8
		-U 22 1/2	24	22 1/2	7/8
1" NPT	1-385HD	-U 2 1/2	4	2 1/2	1 1/16
		-U 4 1/2	6	4 1/2	1 1/16
		-U 7 1/2	9	7 1/2	1 1/16
		-U 10 1/2	12	10 1/2	1 1/16
		-U 13 1/2	15	13 1/2	1 1/16
		-U 16 1/2	18	16 1/2	1 1/16
		-U 22 1/2	24	22 1/2	1 1/16

Series CT385HDL

Threaded Heavy Duty Thermowells for 3/8" Elements (.385 Bore) w/ Lagging Extension

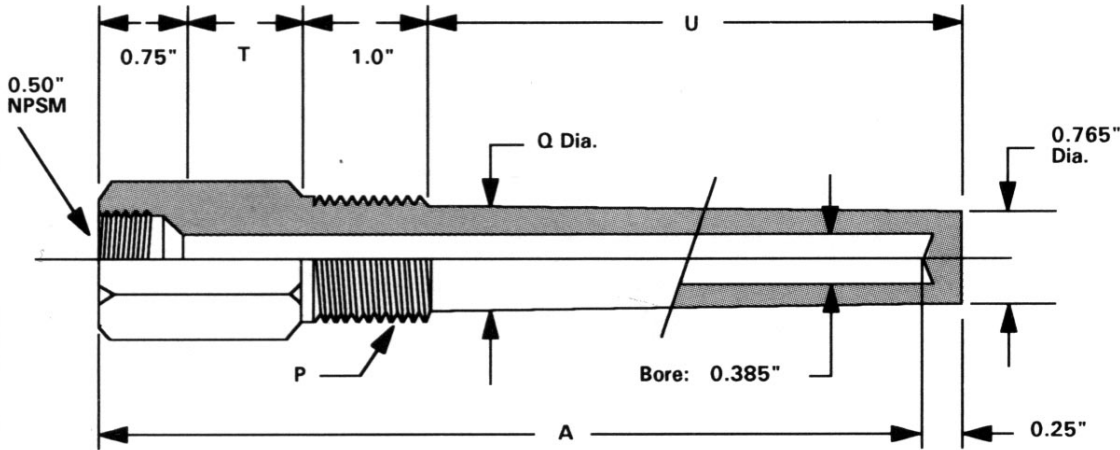

Notes:

1. Cap and chain available upon request.
2. Special finishes are available upon request.
3. Additional lagging extensions available upon request.

External Thread P	Model #	Lag Ext. T	Element Length A	Insert Length U	Shank Dia. Q	
3/4" NPT	3/4-385HDL	-U 2 1/2	2	6	2 1/2	7/8
		-U 4 1/2	3	9	4 1/2	7/8
		-U 7 1/2	3	12	7 1/2	7/8
		-U 10 1/2	3	15	10 1/2	7/8
		-U 13 1/2	3	18	13 1/2	7/8
		-U 19 1/2	3	24	19 1/2	7/8
1" NPT	1-385HDL	-U 2 1/2	2	6	2 1/2	1 1/16
		-U 4 1/2	3	9	4 1/2	1 1/16
		-U 7 1/2	3	12	7 1/2	1 1/16
		-U 10 1/2	3	15	10 1/2	1 1/16
		-U 13 1/2	3	18	13 1/2	1 1/16
		-U 19 1/2	3	24	19 1/2	1 1/16

Series CT260LS

Limited Space Thermowells for 1/4" Elements (.260 Bore)

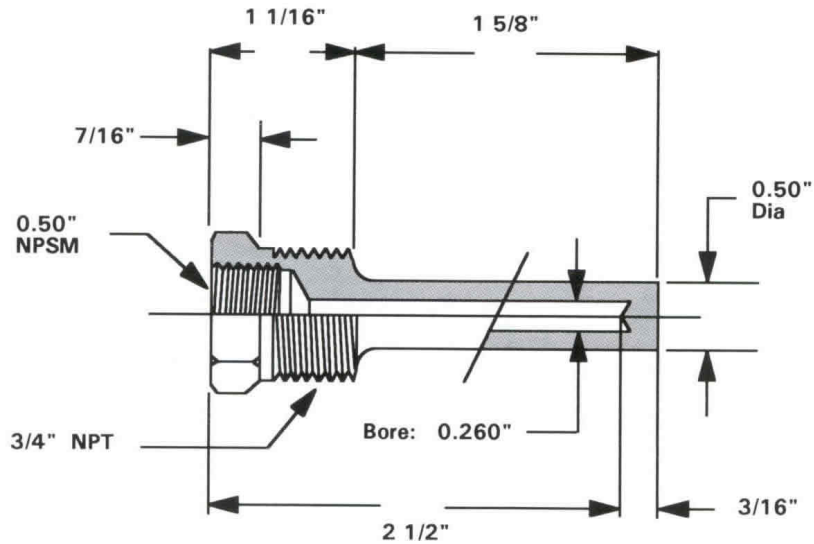

Notes:

- 1. Cap and Chain are available upon request.
- 2. Special finishes are available upon request.

Series CT433B

Standard Brass Thermowells for Commercial HVAC Applications

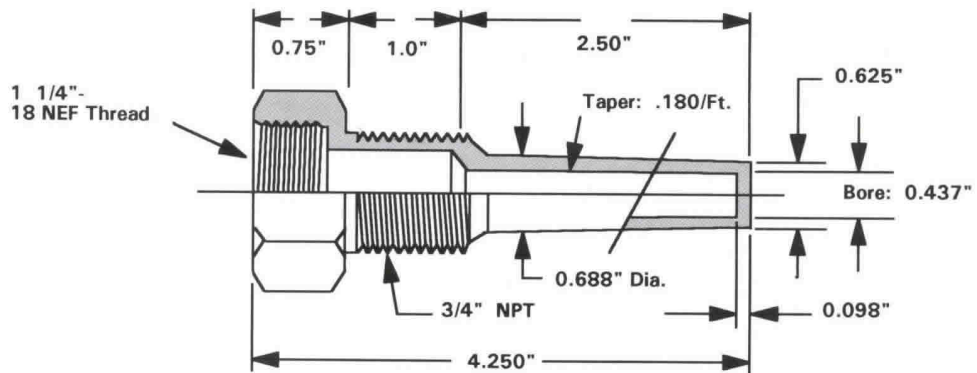

Series CT787IGT

Standard Threaded Thermowells for Industrial Glass Thermometers

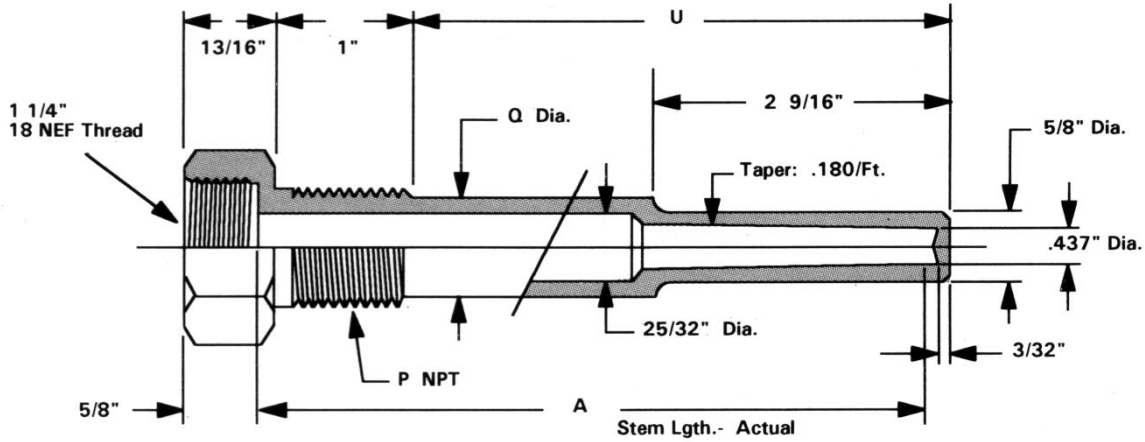

Notes:

1. Series CT781 IGT fit liquid-in-glass thermometers made to S.A.M.A. Standards.
2. 3/4" and 1" NPT connection sizes are standard. Other sizes are available upon request.
3. Socket welds, flanged and heavy duty designs are also available.
4. Additional lagging extensions available upon request.

External Thread P	Model #	Nominal Element Length	Element Length A	Insert Length U	Shank Dia. Q	
3/4" NPT	3/4-787 IGT (S=U+1)	-S 3 1/2	3 1/2	3 5/8	2 9/16	----
		-S 6	6	6 1/8	5 1/16	7/8
		-S 9	9	9 1/8	8 1/16	7/8
		-S 12	12	12 1/8	11 1/16	7/8
		-S 18	18	18 1/8	17 1/16	7/8
		-S 24	24	24 1/8	23 1/16	7/8
1" NPT	1-787 IGT (S=U+1)	-S 3 1/2	3 1/2	3 5/8	2 9/16	----
		-S 6	6	6 1/8	5 1/16	1
		-S 9	9	9 1/8	8 1/16	1
		-S 12	12	12 1/8	11 1/16	1
		-S 18	18	18 1/8	17 1/16	1
		-S 24	24	24 1/8	23 1/16	1

Series CT787IGTL

Standard Threaded Thermowells for Industrial Glass Thermometers w/ Lagging Extension

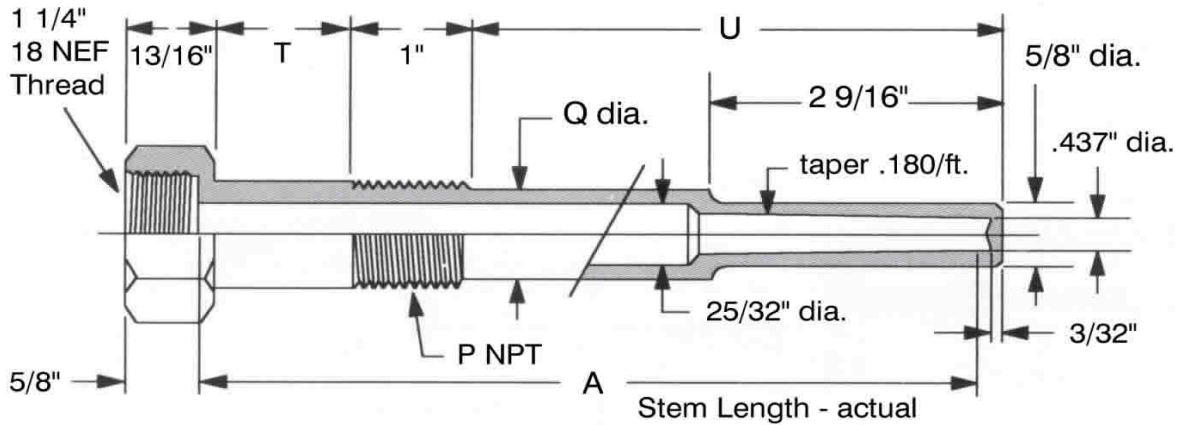

Notes:

1. Series CT781 IGTL fit liquid-in-glass thermometers made to S.A.M.A. Standards.
2. 3/4" and 1" NPT connection sizes are standard.
Other sizes are available upon request.
3. Socket welds, flanged and heavy duty designs are also available.

External Thread P	Model #	Nominal Element Length	Lag Ext. T	Element Length A	Insert Length U	Shank Dia. Q	
3/4" NPT	3/4-787 IGTL (S=U+1)	-S 6	6	2 1/2	6 1/8	2 9/16	---
		-S 9	9	3	9 1/8	5 1/16	7/8
		-S 12	12	3	12 1/8	8 1/16	7/8
		-S 18	18	3	18 1/8	14 1/16	7/8
		-S 24	24	3	24 1/8	20 1/16	7/8
1" NPT	1-787 IGTL (S=U+1)	-S 6	6	2 1/2	6 1/8	2 9/16	---
		-S 9	9	3	9 1/8	5 1/16	1
		-S 12	12	3	12 1/8	8 1/16	1
		-S 18	18	3	18 1/8	14 1/16	1
		-S 24	24	3	24 1/8	20 1/16	1

Series CT260F

Standard Flanged Thermowells for 1/4" Elements (.260 Bore)

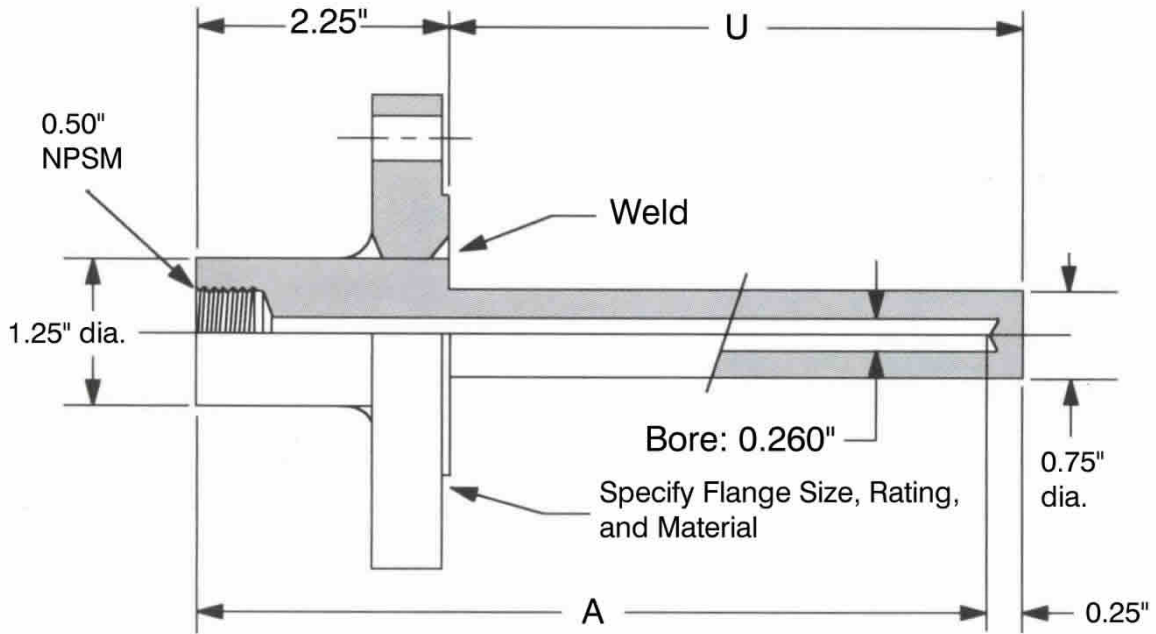

Notes:

1. Cap and chain are available upon request.
2. Special finishes are available upon request.
3. For CT260 F, stepped shanks are available upon request.

Model #	Element Length A	Insert Length U
CT 260 F	-U 2	4
	-U 4	6
	-U 7	9
	-U 10	12
	-U 13	15
	-U 16	18
	-U 22	24

Series CT385F

Standard Flanged Thermowells for 3/8" Elements (.385 Bore)

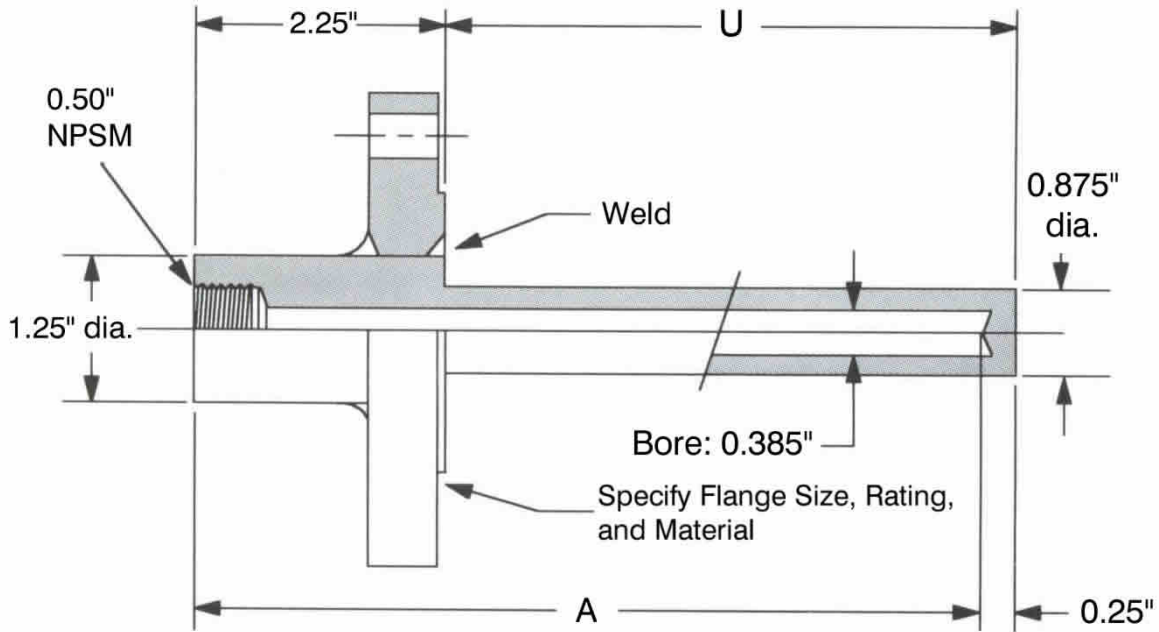

Notes:

- 1. Cap and chain are available upon request.
- 2. Special finishes are available upon request.

Model #	Element Length A	Insert Length U
CT 385 F	-U 2	4
	-U 4	6
	-U 7	9
	-U 10	12
	-U 13	15
	-U 16	18
	-U 22	24

Series CT260FHD

Heavy Duty Flanged Thermowells for 1/4" Elements (.260 Bore)

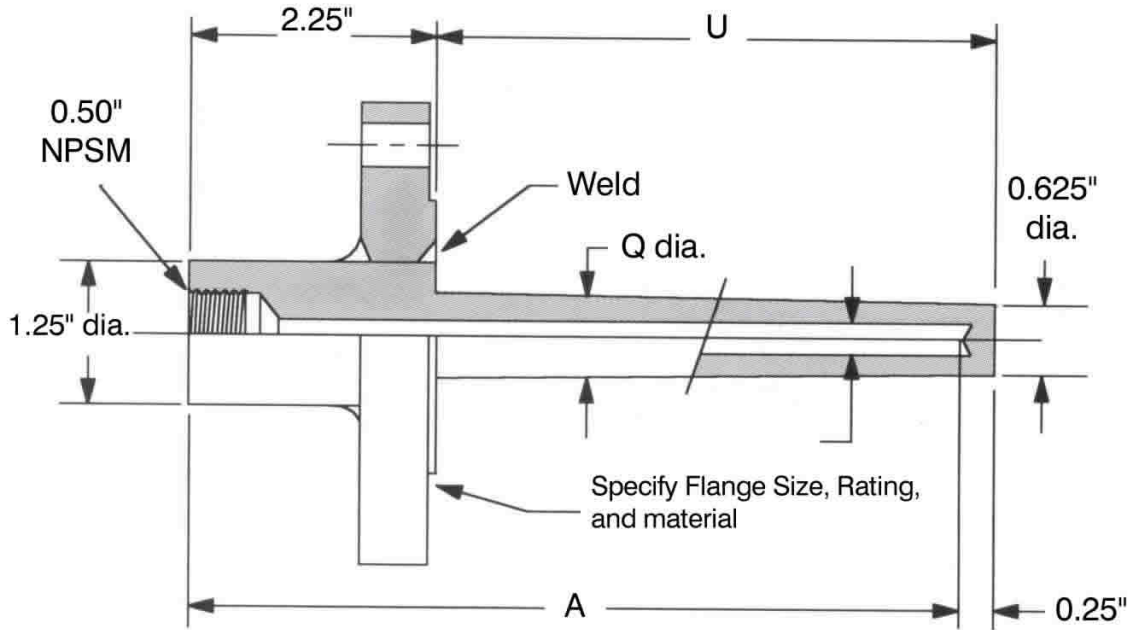

Notes:

1. Cap and chain available upon request.
2. Special finishes are available upon request.

Model #	Element Length A	Insert Length U	Shank Dia. Q
CT 260 FHD	-U 2	4	1" Flange & Smaller Q = 7/8
	-U 4	6	
	-U 7	9	
	-U 10	12	-----
	-U 13	15	
	-U 16	18	1 1/2" Flange & Smaller Q = 1 1/16
	-U 22	24	

Series CT385FHD

Heavy Duty Flanged Thermowells for 3/8" Elements (.385 Bore)

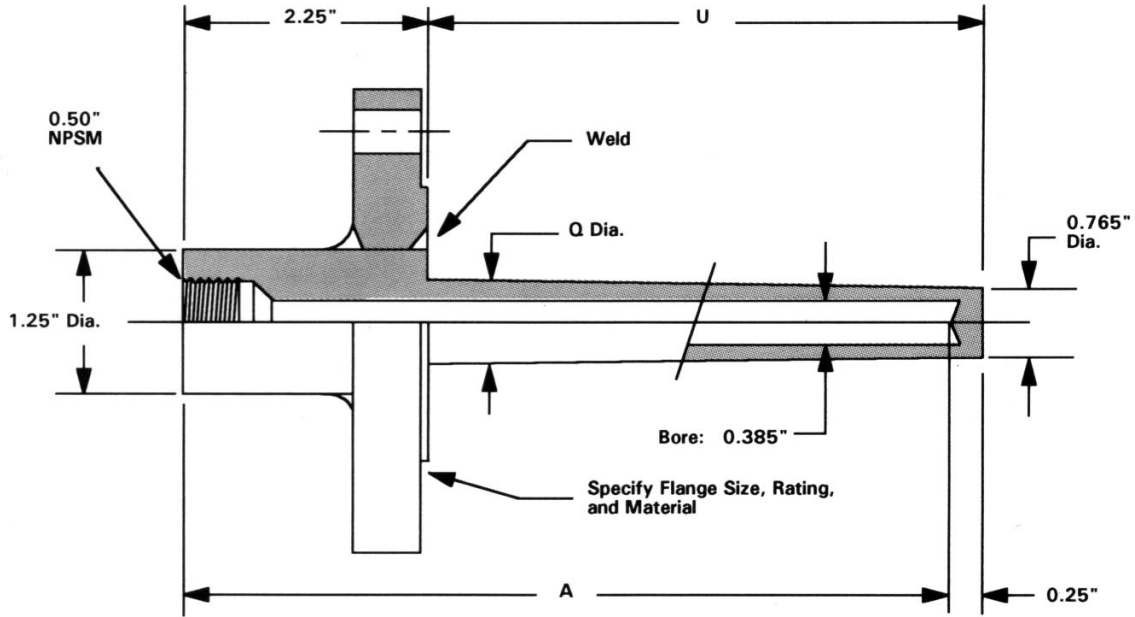

Notes:

1. Cap and chain available upon request.
2. Special finishes are available upon request.

Model #	Element Length A	Insert Length U	Shank Dia. Q
-U 2	4	2	1" Flange & Smaller
-U 4	6	4	Q = 7/8
-U 7	9	7	
-U 10	12	10	-----
-U 13	15	13	
-U 16	18	16	1 1/2" Flange & Smaller
-U 22	24	22	Q = 1 1/16

Series CT260 / 385 VS

Van Stone Type Thermowells for 1/4" or 3/8" Elements

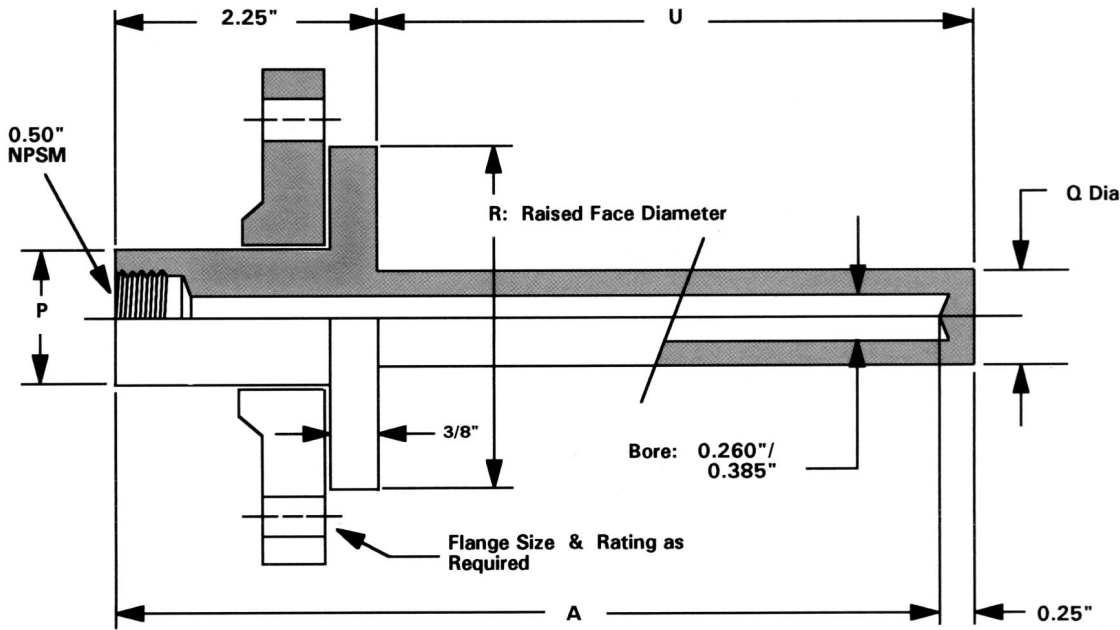

Notes:

1. Cap and chain are available upon request.
2. Special finishes are available upon request.
3. For Series CT260 VS, stepped shanks are available. Please specify when ordering.
4. Other P dimensions are available upon request.
5. Tapered (Heavy Duty) designs are also available.
6. If backing flanges are required, please provide specifications.

P dimensions

Pipe Size Nominal	Actual dia. P	Raised Faced dia.
1	1.315	2
1 1/2	1.900	2 7/8

.260 Bore

Model #	Element length A	Insert length U	Shank dia. Q
CT 260 VS	-U 2	4	3/4
	-U 4	6	3/4
	-U 7	9	3/4
	-U 10	12	3/4
	-U 13	15	3/4
	-U 16	18	3/4
	-U 22	24	3/4

.385 Bore

Model #	Element length A	Insert length U	Shank dia. Q
CT 385 VS	-U 2	4	7/8
	-U 4	6	7/8
	-U 7	9	7/8
	-U 10	12	7/8
	-U 13	15	7/8
	-U 16	18	7/8
	-U 22	24	7/8

Series CT260SW

Socket-Weld Type Thermowells for 1/4" Elements (.260 Bore)

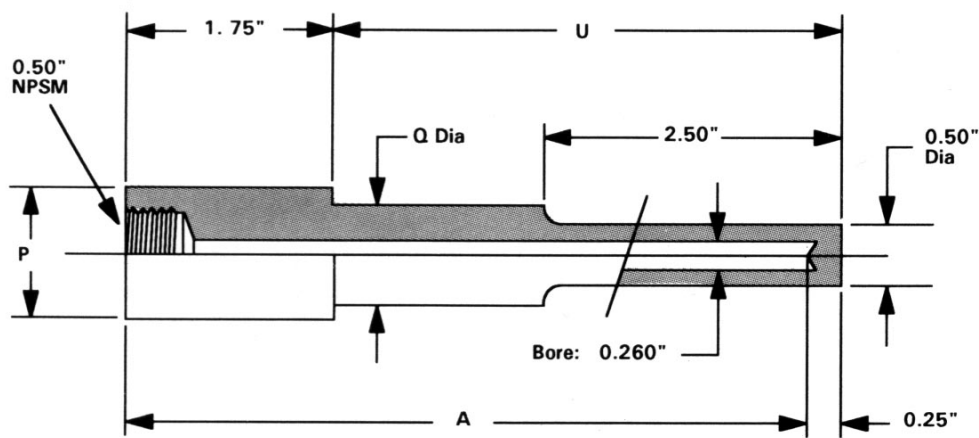

Notes:

1. Cap and chain are available upon request.
2. Special finishes are available upon request.
3. Standard Well is stepped to 1/2" OD except U = 2 1/2".
Please specify if straight shank is required.
4. Other P dimensions are available upon request.
5. Lagging extensions are available upon request.
6. Tapered (Heavy Duty) designs are also available.

Pipe Size P	Model #	Element Length A	Insert Length U	Shank Dia. Q	
3/4" Nominal (1.05" dia.)	3/4-260SW	-U 2 1/2	4	2 1/2	1/2
		-U 4 1/2	6	4 1/2	3/4
		-U 7 1/2	9	7 1/2	3/4
		-U 10 1/2	12	10 1/2	3/4
		-U 13 1/2	15	13 1/2	3/4
		-U 16 1/2	18	16 1/2	3/4
		-U 22 1/2	24	22 1/2	3/4
1" Nominal (1.315" dia.)	1-260SW	-U 2 1/2	4	2 1/2	7/8
		-U 4 1/2	6	4 1/2	7/8
		-U 7 1/2	9	7 1/2	7/8
		-U 10 1/2	12	10 1/2	7/8
		-U 13 1/2	15	13 1/2	7/8
		-U 16 1/2	18	16 1/2	7/8
		-U 22 1/2	24	22 1/2	7/8

Series CT385SW

Socket-Weld Type Thermowells for 3/8" Elements (.385 Bore)

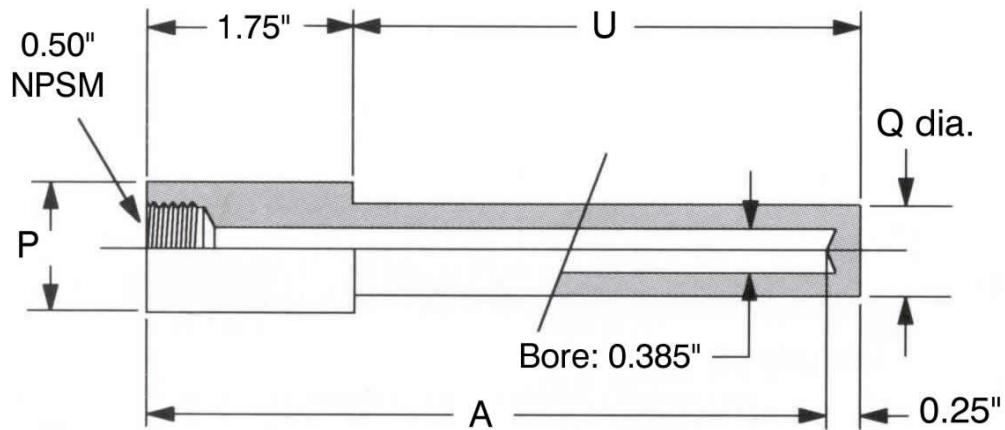

Notes:

1. Cap and chain are available upon request.
2. Special finishes are available upon request.
3. Other P dimensions are available upon request.
4. Lagging extensions are available upon request.
5. Tapered (Heavy Duty) designs are also available.

Pipe Size P	Model #	Element Length A	Insert Length U	Shank Dia. Q	
3/4" Nominal (1.05" dia.)	3/4-385SW	-U 2 1/2	4	2 1/2	49/64
		-U 4 1/2	6	4 1/2	49/64
		-U 7 1/2	9	7 1/2	49/64
		-U 10 1/2	12	10 1/2	49/64
		-U 13 1/2	15	13 1/2	49/64
		-U 16 1/2	18	16 1/2	49/64
		-U 22 1/2	24	22 1/2	49/64
1" Nominal (1.315" dia.)	1-385SW	-U 2 1/2	4	2 1/2	7/8
		-U 4 1/2	6	4 1/2	7/8
		-U 7 1/2	9	7 1/2	7/8
		-U 10 1/2	12	10 1/2	7/8
		-U 13 1/2	15	13 1/2	7/8
		-U 16 1/2	18	16 1/2	7/8
		-U 22 1/2	24	22 1/2	7/8

Series CT260WI

Weld-In Type Thermowells for 1/4" Elements (.260 Bore)

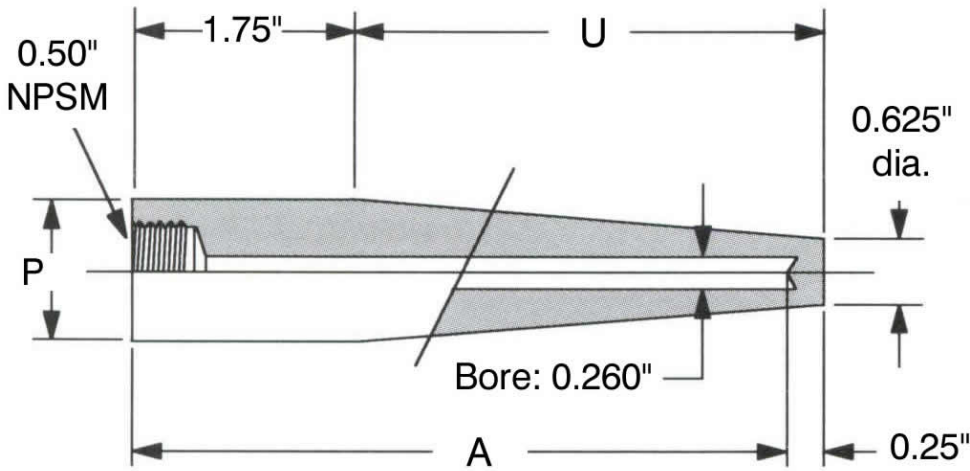

Notes:

1. Cap and chain available upon request.
2. Special finishes are available upon request.
3. Other P dimensions are available upon request.

Pipe Size P	Model #	Element Length A	Insert Length U	
3/4" Nominal (1.05 dia.)	3/4-260WI	-U 2 1/2	4	2 1/2
		-U 4 1/2	6	4 1/2
		-U 7 1/2	9	7 1/2
		-U 10 1/2	12	10 1/2
		-U 13 1/2	15	13 1/2
		-U 16 1/2	18	16 1/2
		-U 22 1/2	24	22 1/2
1" Nominal (1.315 dia.)	1-260WI	-U 2 1/2	4	2 1/2
		-U 4 1/2	6	4 1/2
		-U 7 1/2	9	7 1/2
		-U 10 1/2	12	10 1/2
		-U 13 1/2	15	13 1/2
		-U 16 1/2	18	16 1/2
		-U 22 1/2	24	22 1/2

Series CT260WIL

Weld-In Type Thermowells for 1/4" Elements (.260 Bore) w/ Lagging Extension

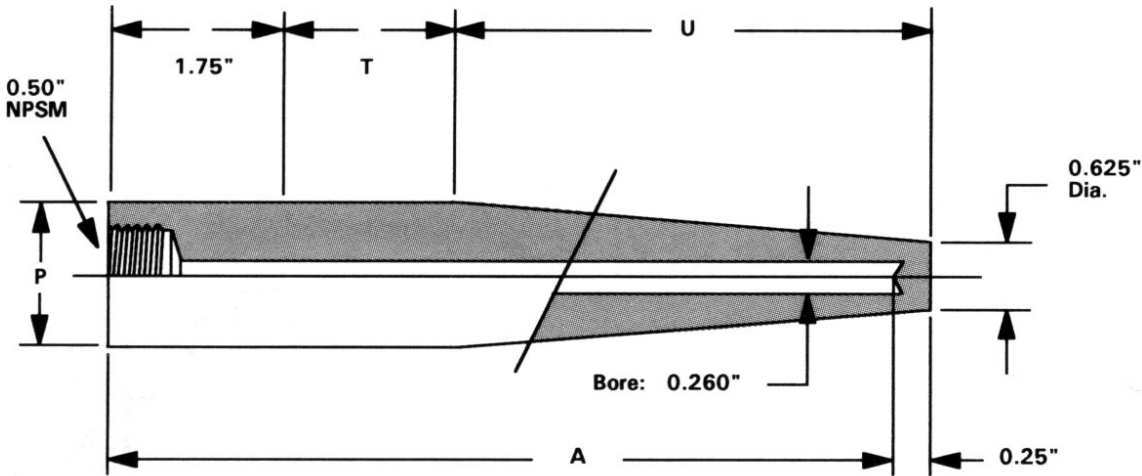

Notes:

1. Cap and chain available upon request.
2. Special finishes are available upon request.
3. Other P dimensions are available upon request.
4. Additional lagging extensions are available upon request.

External Thread P	Model #	Lag Ext. T	Element Length A	Insert Length U	
3/4" Nominal (1.05 dia.)	3/4-260WIL	-U 2 1/2	2	6	2 1/2
		-U 4 1/2	3	9	4 1/2
		-U 7 1/2	3	12	7 1/2
		-U 10 1/2	3	15	10 1/2
		-U 13 1/2	3	18	13 1/2
		-U 19 1/2	3	24	19 1/2
1" Nominal (1.315 dia.)	1-260WIL	-U 2 1/2	2	6	2 1/2
		-U 4 1/2	3	9	4 1/2
		-U 7 1/2	3	12	7 1/2
		-U 10 1/2	3	15	10 1/2
		-U 13 1/2	3	18	13 1/2
		-U 19 1/2	3	24	19 1/2

Series CT385WI

Weld-In Type Thermowells for 3/8" Elements (.385 Bore)

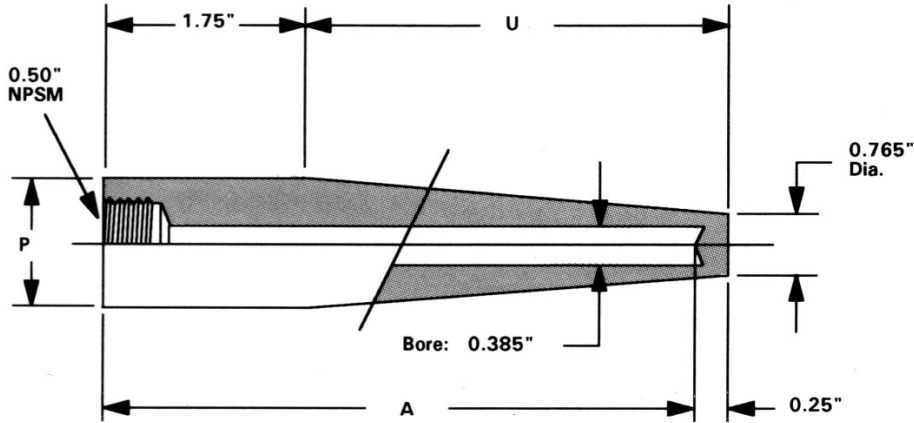

Notes:

1. Cap and chain available upon request.
2. Special finishes are available upon request.
3. Other P dimensions are available upon request.

Pipe Size P	Model #	Element Length A	Insert Length U	
3/4" Nominal (1.05 dia.)	3/4-385WI	-U 2 1/2	4	2 1/2
		-U 4 1/2	6	4 1/2
		-U 7 1/2	9	7 1/2
		-U 10 1/2	12	10 1/2
		-U 13 1/2	15	13 1/2
		-U 16 1/2	18	16 1/2
		-U 22 1/2	24	22 1/2
1" Nominal (1.315 dia.)	1-385WI	-U 2 1/2	4	2 1/2
		-U 4 1/2	6	4 1/2
		-U 7 1/2	9	7 1/2
		-U 10 1/2	12	10 1/2
		-U 13 1/2	15	13 1/2
		-U 16 1/2	18	16 1/2
		-U 22 1/2	24	22 1/2

Series CT385WIL

Weld-In Type Thermowells for 3/8" Elements (.385 Bore) w/ Lagging Extension

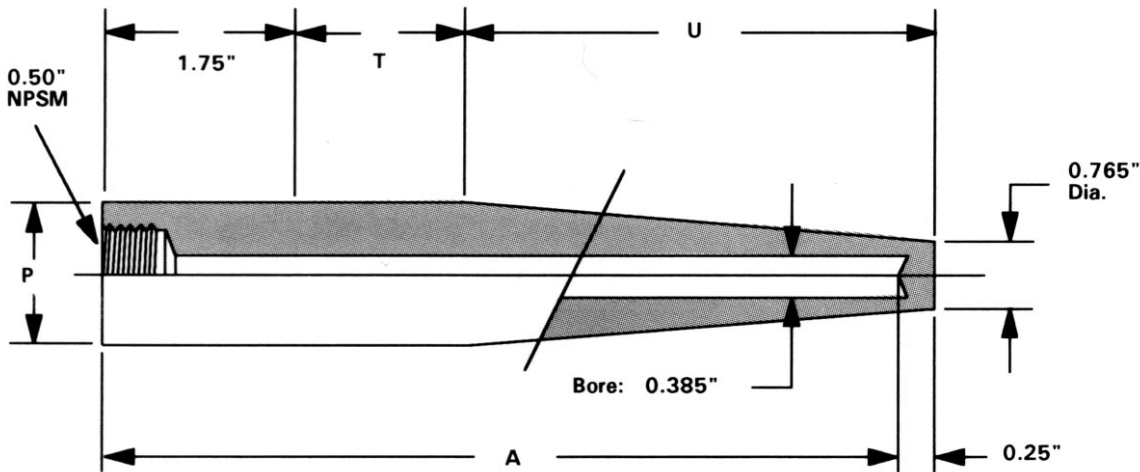

Notes:

1. Cap and chain available upon request.
2. Special finishes are available upon request.
3. Other P dimensions are available upon request.
4. Additional lagging extensions are available upon request.

External Thread P	Model #	Lag Ext. T	Element Length A	Insert Length U
3/4" Nominal (1.05 dia.)	3/4-385WIL	-U 2 1/2	6	2 1/2
		-U 4 1/2	9	4 1/2
		-U 7 1/2	12	7 1/2
		-U 10 1/2	15	10 1/2
		-U 13 1/2	18	13 1/2
		-U 19 1/2	24	19 1/2
1" Nominal (1.315 dia.)	1-385WIL	-U 2 1/2	6	2 1/2
		-U 4 1/2	9	4 1/2
		-U 7 1/2	12	7 1/2
		-U 10 1/2	15	10 1/2
		-U 13 1/2	18	13 1/2
		-U 19 1/2	24	19 1/2

Series CT260SAN

Sanitary Type Thermowells for 1/4" Elements (.260 Bore)

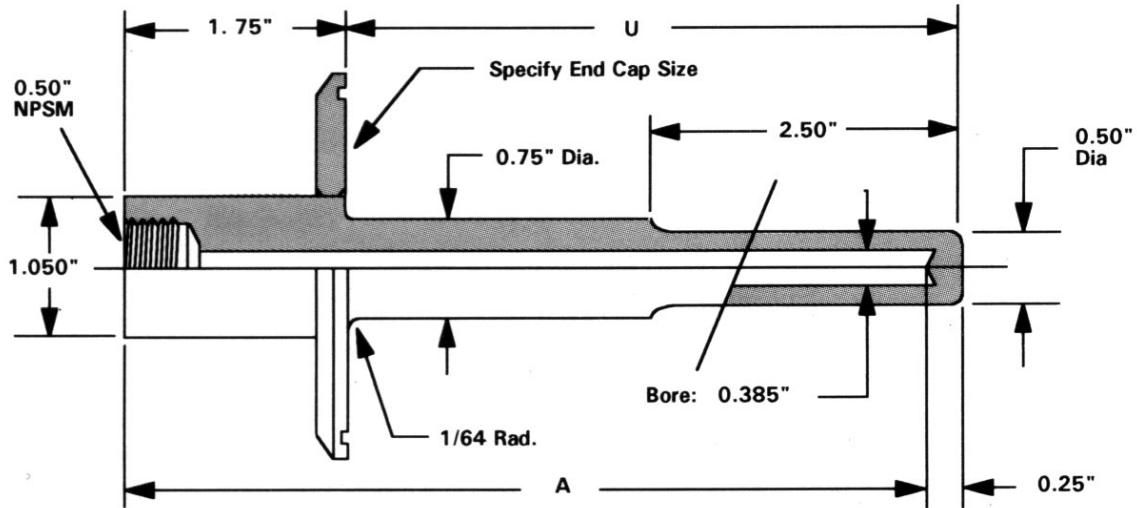

Notes:

1. Cap and chain are available upon request.
2. Special finishes are available upon request.
3. Standard well is stepped to 1/2" OD except U=2 1/2".
Please specify if straight shank is required.
4. Designed to meet 3A Sanitary requirements.
5. Series CT260 SAN-HD (Heavy Duty) thermowell is also available.

Model #	Element Length A	Insert Length U	
260 SAN	-U 2 1/2	4	2 1/2
	-U 4 1/2	6	4 1/2
	-U 7 1/2	9	7 1/2
	-U 10 1/2	12	10 1/2
	-U 13 1/2	15	13 1/2
	-U 16 1/2	18	16 1/2
	-U 22 1/2	24	22 1/2

Series CT385SAN

Sanitary Type Thermowells for 3/8" Elements (.385 Bore)

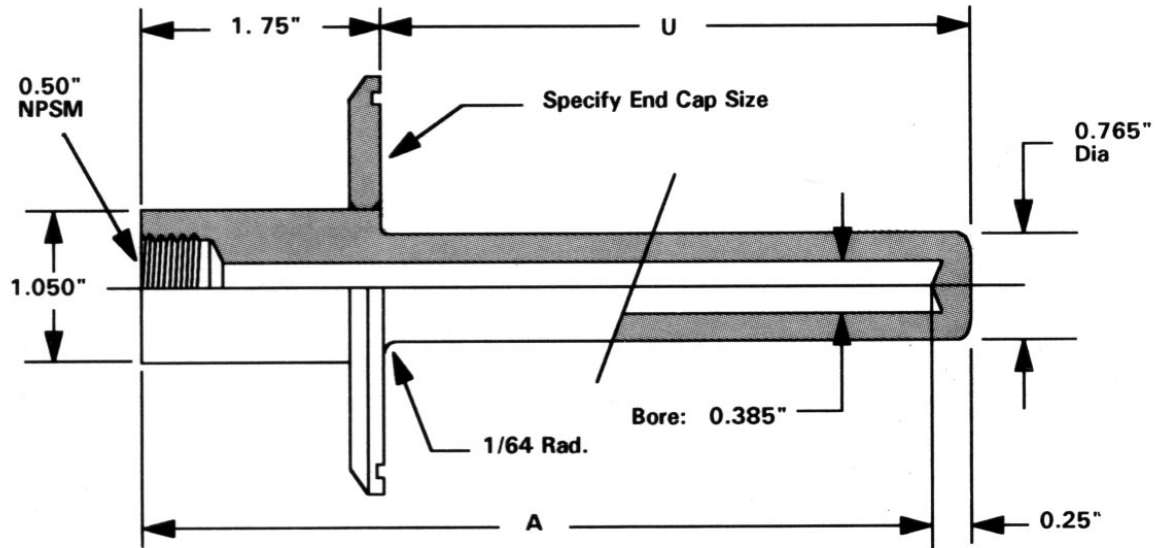

Notes:

1. Cap and chain are available upon request.
2. Special finishes are available upon request.
3. Designed to meet 3A Sanitary requirements.
4. Series CT385 SAN-HD (Heavy Duty) thermowell is also available.

Model #	Element Length A	Insert Length U
CT 385 F	-U 2	4
	-U 4	6
	-U 7	9
	-U 10	12
	-U 13	15
	-U 16	18
	-U 22	24

Series CT260SAWI

Sanitary Weld-In Type Thermowells for 1/4" Elements (.260 Bore)

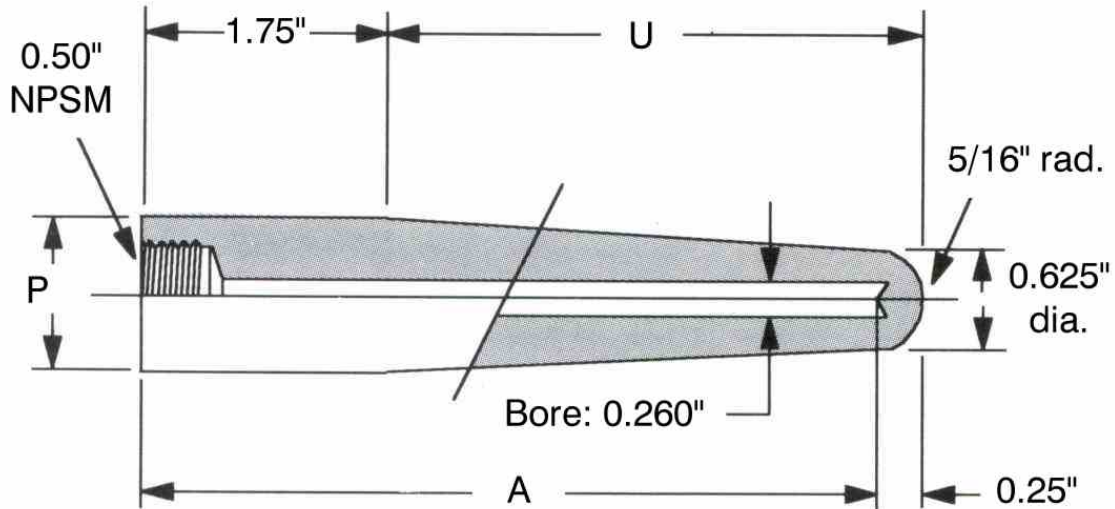

Notes:

1. Cap and chain are available upon request.
2. Special finishes are available upon request.
3. Designed to meet 3A Sanitary requirements.
4. Other P dimensions are available upon request.
5. Lagging extensions are available upon request.

Outside Dia. P	Model #	Element Length A	Insert Length U
1 3/8"	-U 2 1/2	4	2 1/2
	-U 4 1/2	6	4 1/2
	-U 7 1/2	9	7 1/2
	260 SAWI -U 10 1/2	12	10 1/2
	-U 13 1/2	15	13 1/2
1 1/2"	-U 16 1/2	18	16 1/2
	-U 22 1/2	24	22 1/2

Series CT385SAWI

Sanitary Weld-In Type Thermowells for 3/8" Elements (.385 Bore)

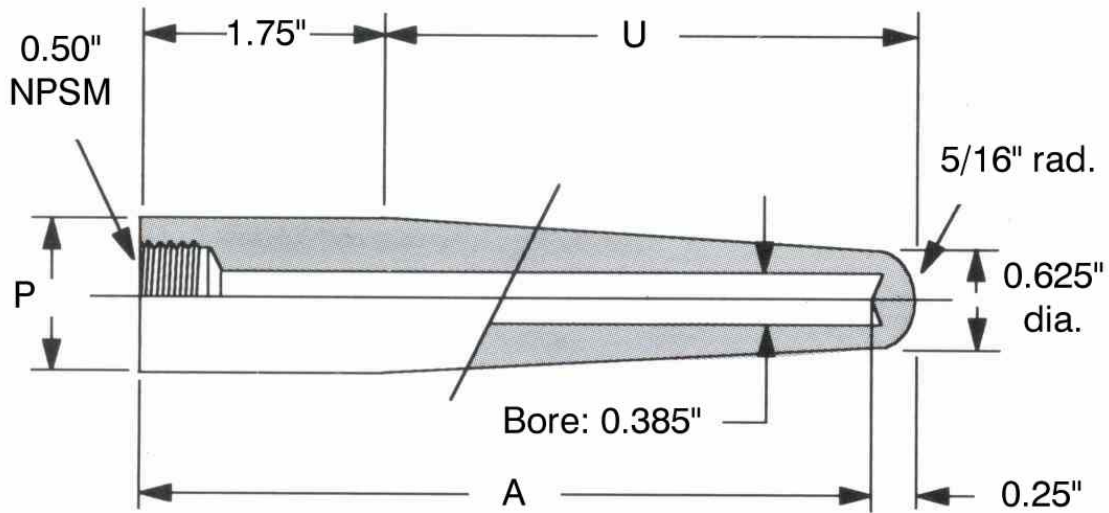

Notes:

1. Cap and chain are available upon request.
2. Special finishes are available upon request.
3. Designed to meet 3A Sanitary requirements.
4. Other P dimensions are available upon request.
5. Lagging extensions are available upon request.

Outside Dia. P	Model #	Element Length A	Insert Length U
1 3/8"	-U 2 1/2	4	2 1/2
	-U 4 1/2	6	4 1/2
	-U 7 1/2	9	7 1/2
	385 SAWI -U 10 1/2	12	10 1/2
	-U 13 1/2	15	13 1/2
1 1/2"	-U 16 1/2	18	16 1/2
	-U 22 1/2	24	22 1/2

Series CT260 / 385 TW

Test Thermowells for 1/4" or 3/8" Elements

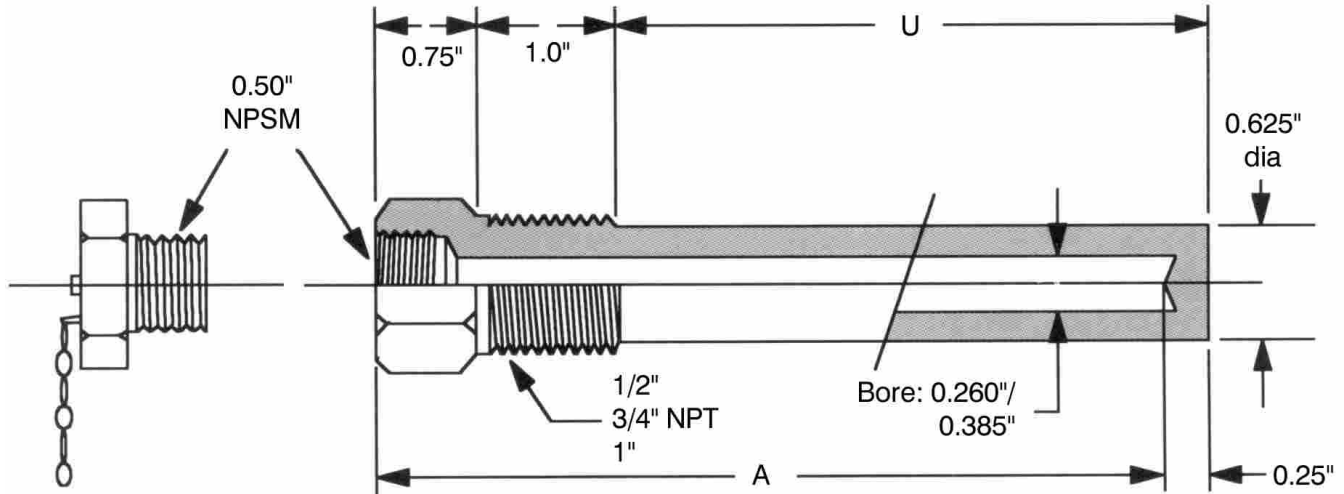

Notes:

1. Cap and chain are standard with Test Well.
2. Special finishes are available upon request.
3. Lagging extensions are available upon request.

Model #	Element Length A	Insert Length U
260 / 385 TW	-U 2	3 1/4
	-U 4	5 1/4
	-U 6	7 1/4
	-U 8	9 1/4
	-U 10	11 1/4
	-U 12	13 1/4